

**CDI**  
*Electronics*

**PRACTICAL OUTBOARD IGNITION  
TROUBLESHOOTING GUIDE**

7th Edition  
\$29.95 USD



**BETTER THAN THE OEM**



|   |         |
|---|---------|
| <b>Introduction and Safety Notice</b> .....   | 2       |
| <b>General Troubleshooting Information</b>  |         |
| DVA Explained .....   | 3       |
| Recommended Marine Shop Electrical Test Equipment and Tools .....                   | 4       |
| Tricks to Testing with Minimal Test Equipment .....                                 | 5       |
| Voltage Drop Measurement .....  | 6       |
| Johnson/Evinrude Model to Year Identification for 1980 and Up Engines .....         | 6       |
| Troubleshooting Battery Charging Issues, Regulator/Rectifiers and Tachometers ..... | 7       |
| Engine Wiring Cross Reference Chart.....  | 9       |
| ABYC Recommended Boat Wiring Color Codes.....                                       | 9       |
| <b>Chrysler/Force Troubleshooting</b>   |         |
| Battery CD Ignitions.....   | 10      |
| Alternator Driven Ignitions (Prestolite) 1983-1992 .....                            | 11      |
| Alternator Driven Ignitions (Mercury Designed Ignitions) 1991-1996 .....            | 21-27   |
| Alternator Driven Ignitions (Mercury CDM Modules) 1996-1999 .....                   | 108-112 |
| <b>Johnson/Evinrude Troubleshooting</b>   |         |
| Battery CD Ignitions .....  | 29      |
| Alternator Driven Ignitions 1971-1978 (Screw Terminal Power Packs) .....            | 30      |
| Flywheel Magnet Orientation .....   | 38      |
| Alternator Driven Ignitions 1977-2006 .....   | 39-67   |
| 60 Optical 3 Cylinder Engines 1996-2001 .....                                       | 67-68   |
| 60 Optical 4 Cylinder Engines 1995-2006 .....                                       | 69-72   |
| 60 Optical 6 Cylinder Engines 1991-2006 .....                                       | 72-77   |
| <b>Mariner Troubleshooting</b>  |         |
| 2 HP One Cylinder Engines 1977-1989 With Points Ignition.....                       | 78-81   |
| <b>Mercury Troubleshooting</b>  |         |
| Battery Intro.....  | 82      |
| Battery CD Ignitions with Points.....   | 83-85   |
| Battery CD Ignitions without Points.....  | 89      |
| Mercury Triggering Magnets .....  | 90      |
| Alternator Driven Ignitions.....  | 91      |
| <b>Mercury/Force CDM Ignitions Troubleshooting</b>                                  |         |
| 2, 3 and 4 Cylinder CDM Ignitions 1994-2006 .....                                   | 108-112 |
| 6 Cylinder CDM Ignitions 1996-2005 2.5L .....                                       | 113-115 |
| 6 Cylinder CDM Ignitions 1994-2003 3.0L .....                                       | 116-117 |
| <b>Tohatsu/Nissan Troubleshooting</b>   |         |
| 2 Stroke Carbureted Ignitions .....   | 118-126 |
| TLDI .....  | 127-128 |
| <b>Yamaha Troubleshooting</b>   |         |
| 2 Stroke Carbureted Ignitions .....   | 129-172 |
| <b>Four Stroke Troubleshooting</b>  |         |
| 2 Stroke Carbureted Ignitions .....   | 173-197 |
| <b>Appendix</b>   |         |
| DVA (Peak Voltage) and Resistance Charts (Introduction).....                        | 198     |
| Chrysler/Force DVA and Resistance Charts .....                                      | 199     |
| Johnson/Evinrude DVA and Resistance Charts .....                                    | 201     |
| OMC Sea Drive DVA and Resistance Charts .....                                       | 203     |
| Yamaha DVA and Resistance Charts.....   | 204     |
| Mercury DVA and Resistance Charts.....  | 211     |
| Glossary of Terms .....   | 213     |
| OMC Stern Drive Electronic Shift Assist Applications and Wiring Diagrams .....      | 216     |
| Ignition Checklist .....  | 219     |

**Disclaimer**

The information contained in this Troubleshooting Guide has been compiled from various sources within the marine industry. Any reference to a specific product or brand is not intended for commercial purposes. References to test equipment and products are based upon the information available to the staff of CDI Electronics. **This information is designed for use as a reference guide by a professional marine technician. CDI Electronics cannot be held liable for the misuse or abuse of the information contained herein.** The staff tries to make the information as accurate as possible. However, CDI Electronics cannot assume responsibility for either the data accuracy or the consequences of the data's application.

All rights reserved. Reproduction or use, without express permission by CDI Electronics, Inc., of editorial or pictorial content, in any manner, is prohibited.

**Safety Issues**

**Always remember to treat the outboard engine with respect. The engine uses high voltage for ignition and contains several moving components. Always be aware of moving mechanical parts, the surrounding area, and the position of your hands and body near the engine.**

- **Never touch electrical components with wet hands.**
- **Whenever the power source is not needed, disconnect the cable from the negative terminal.**
- **Never reverse the battery leads when you connect the battery or disconnect the terminals while the engine is running as severe damage to the electrical system can result.**
- **Never touch high-tension leads (spark plug leads) with any ungrounded tools while the engine is running.**
- **Never install equipment with requirements exceeding the generating power of the engine. Reference the service manual for values.**
- **Attempt to protect the electronic components from water.**
- **Insure fuel lines, harnesses, and oil lines are properly routed. Failure to follow this rule could result in a fire hazard.**
- **Make sure all ground leads are clean and tight.**

## **General Troubleshooting**

### **DVA Explained**

DVA stands for Direct Voltage Adapter, which is used to measure peak AC voltage. This type of measurement of AC voltage takes the absolute peak or highest value of the fluctuating AC voltage signal. Peak readings will be substantially higher than standard or RMS AC values and are typically used when testing marine CD (capacitor discharge) ignition systems due to their high variance in frequency as RPM increases and decreases.

An example would be that the typical RMS AC reading of a wall outlet in North America is 120V. However, a DVA measurement of this same AC voltage would reveal that the peak of the AC sine wave is typically between 160-170V.

Some meters are capable of reading DVA or peak voltage pulses. Many ignition system components produce short, high frequency, AC voltage pulses. A peak-reading analog meter or DVA adapter plugged into a digital meter captures and holds the peak value of an AC sine wave long enough for the human eye to see it displayed on the meter. A conventional meter is incapable of accurately measuring these short-duration voltage pulses. A peak-reading voltmeter has special circuits that allow the meter to capture the maximum voltage produced during these short duration pulses and display the voltage as DVA or peak voltage. Failure to measure DVA correctly can cause good ignition components to be incorrectly diagnosed as faulty.

Typically, the only meters that have built-in peak reading capabilities are analog meters with built-in DVA. Digital meters do not normally have built-in peak reading capabilities. In order for a digital meter to read peak voltage, one will need a DVA adapter, such as CDI part# 511-9773 or 511-9773NL.

Using a DVA adapter, a digital meter must be set to its DC voltage scale. Peak AC voltage is the measurement, but the DVA adapter has a built-in bridge rectifier, which converts AC to DC. The DC voltage setting on a digital meter is required to accurately read DVA.

CDI part# 511-9773 has built-in test leads.

CDI part# 511-9773NL has banana jacks, which uses your existing meter's test leads.

**NOTICE: The DVA readings in this book were compiled using the CDI DVA Adapter (511-9773 or 511-9773NL) with a shielded Digital Multimeter. A Digital multimeter with peak voltage scale cannot be used without the DVA as the meter is expecting a 60 hertz signal where the outboard can have an equivalent frequency of over 1000 hertz.**

**(NOTE) The resistance readings are given for a room temperature of 68°F. Higher temperatures will cause a slightly higher resistance reading.**

**Normally, DVA readings should always be taken with everything hooked up with the exception of the stop circuit.**

The CDI DVA adapter is specifically designed to work with shielded Digital Multimeters. This adapter will simplify the testing of electronic ignition systems, stators, sensors and charging systems. The DVA readings will be approximately the same as any other DVA meter and the specifications listed in the service manuals can be followed without problems (Hopefully a little easier to you).



## General Troubleshooting

### Recommended Marine Shop Electrical Test Equipment and Tools

| Part Number | Description   | Remarks/Use   |
|-------------|---|---|
| 511-0300    | Infrared Temperature Meter                          | Used to read engine, spark plug, lower unit, and hull temperature. Ideal for quickly measuring engine temperature.  |
| 511-4017    | Optical Sensor Tester                               | Used to set timing on a 4 or 6 Cyl engine or test optical sensors on the bench and on the engine. Unique buzzer allows you to set timing without having to see the LED.   |
| 511-4019    | Optical Sensor Tester                               | Unique tester is used to test 3 Cyl optical sensors on the bench and on the engine.   |
| 511-4127    | 6 Cyl Optical Test Harness                          | Test Harness allows you to check the DVA voltages of the stator while connected to the power pack.  |
| 511-5207A 1 | CDM Test Harness                                    | Test the CDM Module DVA on the engine and isolate the kill circuit.   |
| 511-6996    | Remote Starter                                      | Controls most Johnson/Evinrude engines from 1969 thru 2012.   |
| 511-7270    | 4 Cyl Optical Test Harness                          | Test Harness allows you to check the DVA voltages of the stator while connected to the power pack.  |
| 511-7800    | Remote Starter                                      | Controls most Mercury engines from 1970 thru 1978.  |
| 511-7900    | Remote Starter                                      | Controls most Mercury engines from 1979 thru 2000.  |
| 511-9764    | Neon Spark Tester                                   | Sealed single cylinder tester can be used in-line to the spark plug for engine running tests. (With removable ground clip.)   |
| 511-9766    | Sealed Spark Gap Tester                             | Allows you to test up to 8 cylinders for cranking speed tests. Sealed design reduces the chances of injury and fire.  |
| 511-9770    | Piercing Probes<br>(Highly Recommended)             | Allows access to wires for testing without removing the connector. Tiny hole usually reseals itself when wire heats.  |
| 511-9772    | Ammeter Adapter                                     | Used with most Digital multimeters to measure amperage output of the charging system or starter draw amperage.  |
| 511-9773NL  | DVA (Peak Voltage) Adapter                          | Unit automatically compensates for polarity. Can be used with most quality multimeters.   |
| 511-9775    | Load Resistor                                       | To load the output of ignition modules when testing ignition coils.   |
| 511-60A     | CDI Electronics Meter                               | Most cost effective meter for marine use. Has voltage, temperature, amperage, ohms, and DVA readings (includes the 511-9773-NL DVA Adapter).  |
| 520-ST84    | Timing Light w/Tach                                 | Easily check engine timing in bright sunlight. Change the switch and read the engine RPM.   |
| 531-0118T 6 | Marine Engine Diagnostic Software<br><br>(M.E.D.S.) | Windows based Software reads and monitors failure codes on Ficht, ETec, Honda, Mercury, Mercruiser, Suzuki, Volvo Diesel D6, Canbus, and Yamaha engines. See <a href="http://www.cdielelectronics.com">www.cdielelectronics.com</a> for more information. |
| 551-33-1    | Gearcase Filler With Check Valve                    | New design prevents tipping over, and EZ-Fill calibrated check valve creates air-lock to keep lube from running out while installing drain plug. Makes filling lower units easier.  |
| 551-34PV    | Pressure/Vacuum Tester                              | Repairable metal unit does both vacuum and pressure testing.  |
| 551-5110    | Flywheel Holder                                     | New design has a high tensile strength poly coated woven belt for a more secure grip of flywheel and a longer handle provides a more comfortable with less effort.  |
| 553-2700    | Amphenol Pin Tool Set                               | Set contains one each of 553-2697 (insertion), 553-2698 (pin removal), and 553-2699 (socket removal) tools.   |
| 553-4994    | Gauge Ring  | Used to set stator and trigger air gap on Johnson/Evinrude 2 Cyl / 2 Stroke engines from 1977-2006.   |
| 912-9708    | Marine Terminal Kit                                 | Contains 100+ pieces of hard to find terminals and heat shrink.   |
| 961-0002    | Troubleshooting Guide                               | Manual has detailed troubleshooting information and DVA charts.   |
| 991-9705    | Dielectric Grease                                   | Used to keep water and corrosion out of connectors.   |

## **General Troubleshooting**

### **Tricks To Testing With Minimal Test Equipment**

- Please keep detailed records when you repair an engine. If an engine comes in with one cylinder not firing, mark which one on the work order/history.
- Remember to check the compression of all cylinders! It does not make any sense to fix an ignition problem if the engine has a blown cylinder. Don't forget low compression can be caused by something as simple as a bad starter, a low or weak battery.
- An engine requires air, fuel and spark (at the correct time) in order to run. Make sure the engine has all three.
- If the engine has no spark on any cylinder, make sure to disconnect the stop circuit AT THE IGNITION PACK! If the harness or ignition switch is bad, the pack will start firing when you do this.

**Intermittent Firing:** This problem can be very hard to isolate. A good inductive tachometer can be used to compare the RPM on all cylinders up through WOT (wide-open throttle). A significant difference in the RPM readings can help pinpoint a problem quickly.

**Visually Check the Stator, Trigger, Rectifier/Regulator and Flywheel:** Cracks, burned areas and bubbles in or on the components indicate a problem. If the battery charge windings on the stator are dark brown, black or burned on most or all of the posts, the rectifier/regulator is likely shorted as well. Any sign of rubbing on the outside of the stator indicates a problem in the upper or lower main bearings. A cracked trigger or outer charging magnets can cause many problems ranging from misfiring to no spark at all. Loose flywheel magnets can be dangerous, check the tightness of the bonding adhesive.

**Rectifier/Regulators** can cause problems ranging from a high-speed miss to a total shutdown. An easy check is to disconnect the stator leads going to the rectifier (Make sure to insulate them) and retest. If the problem is gone – replace the rectifier/regulator.

### **Johnson/Evinrude**

**Open Timer Bases:** When all cylinders spark with the spark plugs out, but no fire with them installed, try re-gapping the sensors using P/N: 553-9702 Gap Gauge. (See the section on OMC ADI Ignitions).

**Engines with S.L.O.W. Features:** If the customer is complaining that the engine won't rev up and shakes real bad, the S.L.O.W. function could be activating. If the engine is NOT overheating, a temperature sensor or VRO sensor failing early can cause this problem. Disconnect the TAN wires at the power pack and retest. If the engine performs normally, reconnect the tan wires one at a time until the problem recurs, then replace the last sensor you connected. Make sure that all of the TAN wires are located as far as possible from the spark plug wires. Also check the blocking diode in the engine harness.

### **Mercury 6 Cylinder Engines with ADI (Alternator/Stator Driven Ignition) Ignitions**

**If more than one cylinder is not firing:** Replace BOTH switch boxes unless you can pin the problem down to the trigger. Replacing just one switch box can result in damage to the engine if the remaining switch box on the engine has a problem in the bias circuit.

**Always check the bias circuit:** Disconnect the White/Black jumper between the switch boxes and check the resistance from the White/Black terminal on each switch box to engine ground. You should read 12-15,000 ohms on stock switch boxes, and 9,000-9,800 ohms on racing switch boxes. MAKE SURE THE READING IS THE SAME ON BOTH SWITCH BOXES! Any problem with the bias circuit and BOTH switch boxes must be replaced as a set.

**No Spark on 1, 3, 5 or 2, 4, 6:** Swap the stator leads from one switch box to the other. If the problem moves, replace the stator. If the problem remains on the same cylinders, replace the switch box. If the stator is replaced and the problem is still present, try another flywheel.

**No Spark on One Cylinder:** This can be caused by a defective blocking diode in the other switch box. Disconnect the White/Black jumper between the switch boxes and retest. If all cylinders are now firing, replace the switch box that was originally firing all three cylinders. To verify this condition, swap the trigger leads on the switch box that was originally firing all three cylinders. If the miss moves to another cylinder, the switch box is bad.

## General Troubleshooting

### Voltage Drop Measurement

Start by using a good digital auto-ranging voltmeter capable of reading 1/10<sup>th</sup> of a volt. The use of an auto-ranging meter will allow for more accurate testing without damaging the meter due to an incorrect range setting.

Remove the spark plug wires from the spark plugs and connect them to a spark gap tester and remove the emergency stop clip as well. This prevents the engine from starting and also reduces the chance of getting shocked by the ignition system.

The use of an ohmmeter to test a conductor or switch contact for their condition is not the best tool to use. In most cases, it is preferable to use a volt drop test to make sure the conductor, as well as the connection, is in good condition.

Before testing, remove and clean all battery cables and connection points.

#### Testing the Positive Battery Cable to the Engine

1. Select the DC Volts position on the meter.
2. Connect the Red (Positive) lead on the meter to the positive battery POST.
3. Connect the Black (Negative) lead on the meter to the starter solenoid terminal where the positive battery cable is connected.
4. Using a remote start switch, activate the starter solenoid to spin the engine and observe the reading on the meter. A reading above 0.6V indicates a bad cable or bad connection.
  - A. If the meter reads above 0.6V, move the Black lead on the meter to the positive battery cable terminal on the starter solenoid and retest. If the reading drops to below 0.6V, the cable connection is bad.
  - B. If the meter still reads above 0.6V, move the Black lead on the meter to the positive battery cable terminal on the battery and retest. If the reading drops to below 0.6V, the cable is bad or undersized.

(Service Note) A bad power connection to the ignition or battery charging system can be found by connecting the Black lead on the meter to the power connection of the ignition system or charging system; then working your way back to the battery positive post. At no time should you see a reading above 1V.

#### Testing the Negative Battery Cable to the Engine

1. Select the DC Volts position on the meter.
2. Connect the Black (Negative) lead on the meter to the negative battery POST.
3. Connect the Red (Positive) lead on the meter to the engine block where the negative battery cable is connected.
4. Using a remote start switch, activate the starter solenoid to spin the engine and observe the reading on the meter. A reading above 0.6V is an indicator of a bad cable or bad connection.
  - A. If the meter reads above 0.6V, move the Red lead on the meter to the negative battery cable terminal on the engine block and retest. If the reading drops to below 0.6V, the cable connection is bad.
  - B. If the meter still reads above 0.6V, move the Red lead on the meter to the negative battery cable terminal on the battery and retest. If the reading drops to below 0.6V, the cable is bad or undersized.

A bad ground connection to the ignition and battery charging system can be found by connecting the Red lead on the meter to the ground connection of the ignition or battery charging system; then working your way back to the battery negative post. At no time should you see a reading above 1V.

#### Johnson/Evinrude Model to Year Identification for 1980 and newer Engines

| "INTRODUCES" |   |   |   |   |   |   |   |   |   |
|--------------|---|---|---|---|---|---|---|---|---|
| I            | N | T | R | O | D | U | C | E | S |
| 1            | 2 | 3 | 4 | 5 | 6 | 7 | 8 | 9 | 0 |

Example: J150TTLCE would be a 1989 150 HP Johnson and a E175STEU would be a 1997 175 HP Evinrude.

## **General Troubleshooting**

### **Battery Differences**

Maintenance-free batteries (gel cells / AGM / closed-case) have thin plates. They're ideal for a charging system that maintains a typical charge between 12.5V – 14.4V, but not for outboards, where batteries are commonly drained by accessories while fishing, etc. i.e. when there is no charge applied to a battery while the battery is in use. Its thin plates cannot withstand constant discharging and charging. It will develop weak and/or dead cells due to this behavior.

Maintenance-free batteries should not be used because their life span is shortened when used on an outboard application. A new fully-charged, maintenance-free battery will work fine at first, but under constant discharging and charging, something that style battery is not designed for, it will eventually become weak and/or develop dead cells, thus unable to accept a full charge, thus putting a rectifier/regulator at extreme risk of failure.

Non-maintenance-free batteries (lead-acid flooded cell; has vent caps on its top) have heavy, thick plates. They're ideal for outboards, where batteries are commonly drained by accessories while fishing, etc. i.e. when there is no charge applied to a battery while the battery is in use. Its heavy plates can withstand constant discharging and charging. These batteries have much more reserve time and are much more suited for this behavior.

The recommended type of battery for outboards is a single (NOT more than one) 850+ CCA dual purpose or cranking/starting non-maintenance-free battery. Make sure to charge any battery off of a battery charger BEFORE installing. NEVER allow the stator to charge a battery. The stator is designed to maintain the battery's voltage at an optimum charge. It's not designed to charge a dead or weak battery. Make sure the battery is always charged off of a battery charger before each use of the boat to maintain optimum performance and life of the battery, stator and regulator. If multiple accessories are used, a 2nd battery, NOT connected to the starting battery, is recommended. If desired, a make-before-break switch can be used between the two batteries. Make sure to also charge this battery off of a battery charger before each use.

NEVER jump-start a battery while an outboard engine is running. This can cause damage to the rectifier/regulator. Always use a battery charger to charge a battery. If no battery charger is available, the rectifier/regulator's Yellow wires may be disconnected while jump-starting to avoid damaging the rectifier/regulator.

### **Troubleshooting Battery Charging Issues**

Regardless if the charging issue is overcharging or not charging at all, the #1 cause of all charging issues is the battery often due to improper style and/or charging neglect. #2 is the battery's connections. #3 is the rectifier/regulator. #4 is the stator.

The battery and/or its connections often cause the rectifier/regulator (and in rare cases, the stator) to become faulty, thus often creating more than one faulty component (Example: Bad battery causing the rectifier/regulator to become faulty). The rectifier/regulator is more susceptible to failure than the stator because its diodes are more fragile than the stator's typical 12-18 gauge wire encompassing its frame.

A rectifier's job is to convert the stator's AC signal into DC to charge the battery. In non-regulated applications (rectifier only), the battery acts as its own regulator, which is not designed to do. When it can no longer self-regulate proper voltage from the rectifier, usually due to dead and/or weak cells, it poses a serious threat to rectifier failure and thus needs replacing. This is why a regulator is crucial to a healthy charging system. A regulator's job is to regulate battery voltage between 12.5 – 15.4V.

In this case, it is recommended to replace the rectifier with a combination rectifier/regulator and replace the battery with a dual purpose or cranking/starting non-maintenance-free battery. This way, the battery will no longer have to self-regulate. The rectifier/regulator will take that responsibility, thus giving the entire charging system optimum life.

1. Check all battery connections, particularly at engine ground. Make sure all connections are corrosion-free and tight. Do NOT use wing nuts. They will loosen over time due to vibration, causing battery and/or rectifier/regulator failures.
2. If no change, remove all batteries and try a single (NOT more than one), known-good, fully-charged off a battery

## **General Troubleshooting**

charger, 850+ CCA dual purpose or cranking/starting non-maintenance-free battery (NOT a closed-case battery). Make sure the battery is a lead-acid flooded cell (has vent caps on its top). Make sure to charge any battery off of a battery charger BEFORE installing. NEVER allow the stator to charge a battery. The stator is designed to maintain the battery's voltage at an optimum charge. It's not designed to charge a dead or weak battery. Recheck all connections, making sure they are corrosion-free and tight. NEVER jump-start a battery while an outboard engine is running. This can cause damage to the rectifier/regulator. Always use a battery charger to charge a battery. If no battery charger is available, the rectifier/regulator's Yellow wires may be disconnected while jump-starting to avoid damaging the rectifier/regulator.

3. If no change, measure DVA voltage across the stator's battery charge wires (typically Yellow wires) while connected to the regulator/rectifier. At idle, DVA will normally be between 8-25V DVA. If not, disconnect the Yellow wires from the regulator/rectifier and retest for 17-50V DVA at idle. If not, the stator is possibly faulty. Visually inspect the stator for browning, varnish dripping and any signs of overheating. If the stator shows any signs of overheating, replace the stator.
4. If the stator DVA checks and visually looks good, test the regulator/rectifier as given below.

### **Regulator/Rectifiers Tests**

1. With all wires connected and the engine running at approximately 1500 RPM, check the DVA voltage from each battery charge wire (typically Yellow wire) to engine ground. The two readings must be within 1.5 volts of each other (i.e. if one is reading 20 volts, the other has to read between 18.5 and 21.5 volts). If the readings are not equal, go to step 3. If they are equal, go to step 2.
2. Check DVA voltage from each of the Yellow wires to the Red wire going to the solenoid. The two readings must be within 1.5 volts of each other. If the readings are unequal, go to step 3. If they are equal on both this step and step 1, the regulator/rectifier and battery charging portion of the stator are good.
3. If the readings are unequal, place a mark across the connection between the stator and regulator/rectifier that measured low. Turn the engine off and swap the stator leads. Crank the engine up and retest. The component (stator or regulator/rectifier) that has the marked wire with the low reading is bad.
4. Disconnect the regulator's Gray wire. At 800-1000 RPM, check the DVA voltage on the Gray wire FROM THE REGULATOR measured to engine ground. The reading should be at least 8V DVA. If below 8V DVA, see TACHOMETER TESTS below.

### **Regulator/Rectifier Bench Tests**

1. Diode plate check:  
With all wires disconnected from the regulator/rectifier, using a meter set on its Diode scale, test the diodes from each of the two battery charge wires/terminals (typically Yellow wires/terminals) to the Red wire/terminal. You should get a reading one way but not the other. Check the resistance from each of the Yellow wires/terminals to case ground. You should have a high reading, typically in the M range. The Red wire/terminal should not read to ground, but may show a very high reading (25M ohms or more).
2. Tachometer Circuit:  
With all wires disconnected from the regulator/rectifier, check resistance between the Gray wire and engine ground. You should read approximately 10K (10,000) ohms. Both (Gray to Red) and (Gray to each of the Yellow) wires should be a high reading, typically in the M range.

### **Tachometer Tests**

1. Disconnect the regulator's Gray wire. At 800-1000 RPM, check the DVA voltage on the Gray wire FROM THE REGULATOR measured to engine ground. The reading should be 8V+ DVA. If not, replace the regulator.
2. If at least 8V DVA, run a jumper wire from the Gray wire out of the harness to one of the stator's Yellow wires.
3. If still no tachometer signal, try a known-good tachometer.
4. If still no tachometer signal, replace the stator.



# General Troubleshooting

**General**

## Checking Maximum Battery Output

1. Install an ammeter capable of reading the maximum output in line on the Red wire connected to the starter solenoid.
2. Connect a load bank to the battery.
3. In the water or on a Dynamometer, start the engine and bring the RPM up to approximately 3500.
4. Turn on the load bank switches to increase the battery load to match the rated output of the stator.
5. Check the ammeter. If the amperage is low:
  - A. Check the Purple wire for voltage while the engine is running. You should see the same voltage as the battery.
  - B. Connect a jumper wire from the Positive battery cable to the Purple wire and recheck the ammeter. If the amperage is now correct, there is a problem in the harness or key switch.
6. If the amperage is correct, but the battery voltage remains low, replace the battery.

| <b>Engine Wiring Cross Reference Chart for Most Outboards</b> |                     |   |  |                        |                                  |  |                  |              |
|---|---------------------|---|--|------------------------|----------------------------------|--|------------------|--------------|
| Circuit   | Mercury PRE-1978    | Mercury 1978 & UP                                     | OMC                                    | Yamaha                 | Force PRE-1994                   | Force 1994 & UP                                  | Suzuki           | Tohatsu      |
| Power   | Red                 | Red   | Red                                    | Red                    | Red                              | Red/Purple                                       | White            | Red          |
| Ign. Switch   | White               | Purple  | Purple                                 | Yellow                 | Blue                             | Red/Blue   | Gray             | Red          |
| Eng. Gnd.   | Black               | Black   | Black                                  | Black                  | Black                            | Black  | Black            | Black        |
| Stop Circuit  | Orange Salmon White | Black/Yellow  | Black/Yellow                           | White                  | White                            | Black/Yel  | Green Red Blue   | Brown        |
| Eng. Start  | Yellow              | Yellow/Red  | Yellow/Red                             | Brown                  | Yellow                           | Yellow/Red                                       | Brown Yellow/Red | Green        |
| Tach  | Brown               | Gray  | Gray                                   | Green                  | Purple                           | Gray   | Yellow           | White        |
| Battery Charge  | Yellow/Red          | Yellow Yellow/Black                                   | Yellow Yellow/Black                    | Green                  | Yellow                           | Yellow Yellow/Blk                                | Yellow/Red       | Yellow White |
| Stator CDI Power  | Red White Blue(a)   | Blue Blue/White Red Red/White Green/White White/Green | Brown Brown/Yel Brown/BlackBrown/White | Blue Brown Red Blk/Red | Blue Yellow Brown/Blue Brown/Yel | Blue Blue/White Red Red/White Green/WhtWht/Green | Green Black/Red  | Red          |
| Choke   | Gray Blue           | Yellow/Black  | Purple/White                           | Blue                   | Green                            | Yellow/Blk                                       | Orange           | Blue         |
| Overheat Eng. Temp  | Tan                 | Tan   | Tan (b) White/Blk (c)                  | Pink                   | Orange                           | Tan  | Green/Yellow     | Light Blue   |

(a) Ignition Driver Systems only, all others were battery driven systems.  
 (b) The stripe color on the Tan wire indicates the temperature at which the sensor trips.  
 (c) The White/Black wire is the cold engine temp indicator and shorts to GND. At approx. 105 deg. F.  
 (Blk = Black) (Wht = White) (Gry=Gray) (Yel=Yellow)

| <b>ABYC Recommended Boat Wiring Color Codes</b> |                             |   |
|---|-----------------------------|---|
| Color   | Function                    | Comments  |
| Yellow/Red Strips (YR)                          | Engine Start Circuit        |   |
| Brown/Yellow Stripe (BY)                        | Bilge Blower                | Alternate color is Yellow(Y)  |
| Yellow Stripe (Y)                               | Bilge Blower                | If used for DC negative, blower MUST be Brown/Yellow Stripe                                       |
| Dark Gray (Gy)                                  | Navigation Lights           | Fuse or Switch to lights  |
| Dark Gray (Gy)                                  | Tachometer                  |   |
| Brown (Br)                                      | Generator/Alternator        | Charge Indicator Lights, Fuse or Switch to pumps  |
| Orange (O)                                      | Accessory Power             | Ammeter to alternator output and accessory fuse or switches. Distribution Panel accessory switch. |
| Purple (Pu)                                     | Ignition Instrument Power   | Ignition switch to coil and electrical instruments. Distribution Panel to electric instruments.   |
| Dark Blue                                       | Cabin and instrument lights | Fuse or switch to lights  |
| Light Blue (Lt Bl)                              | Oil Pressure                | Oil sender to gauge   |
| Tan   | Water Pressure              | Temperature sender to gauge   |
| Pink (Pk)                                       | Fuel Gauge                  | Fuel sender to gauge  |
| Green/White Stripe                              | Tilt/Trim down or in        | Tilt and Trim Circuits  |
| Blue/White Strip                                | Tilt/Trip up or out         | Tilt and Trim Circuits  |

## Chrysler/Force Troubleshooting

### Chrysler

Points Type Ignitions with Amplifiers (With 115-3301/523301-1/6CB2012 Power Pack)  
(Preamps are electronic replacements for points)

**DANGER!! DO NOT USE AUTOMOTIVE OIL FILLED IGNITION COILS ON AN OUTBOARD ENGINE USING POINTS AND CONDENSOR IGNITION AS THE OIL FILLED COILS CAN EXPLODE!!!!** If the OEM coil is not available, you can substitute Johnson/Evinrude P/N: 389569.

A large proportion of the problems with the battery CD units are caused by low battery voltage or bad ground connections. Low voltage symptoms are weak spark or erratic firing of cylinders. Maintenance free batteries are NOT recommended for this application. **WARNING!!** Battery reversal will cause severe damage to the CD module and rectifier.

(NOTE) The Chrysler CD modules are similar to the OMC CD modules with the exception of wire colors. The chart below will assist you as a general guideline for the Chrysler units:

|                    |                                     |
|--------------------|-------------------------------------|
| Red                | +12V from battery (RF Noise Filter) |
| Blue               | +12V from the Key Switch            |
| Gray               | + Terminal of ignition coil         |
| White              | OEM Tachometer signal               |
| White/Black Stripe | Points or Preamp Module             |
| Black              | Engine ground                       |

#### No Spark at all:

1. Clean all battery connections and engine grounds.
2. Make sure the CD module is grounded. Units using rubber shock mounts require a ground wire fastened from the pack to the engine block.
3. Connect a spark gap tester to the high tension lead coming from the ignition coil and set it to approximately  $\frac{1}{2}$ ". If it sparks when you crank the engine over, there is a problem in the distributor cap, rotor button or spark plug wires. Remember the distributor cap is a two piece design and may not show the arcing until it is disassembled.

#### Wiring Connection for Testing CD Module

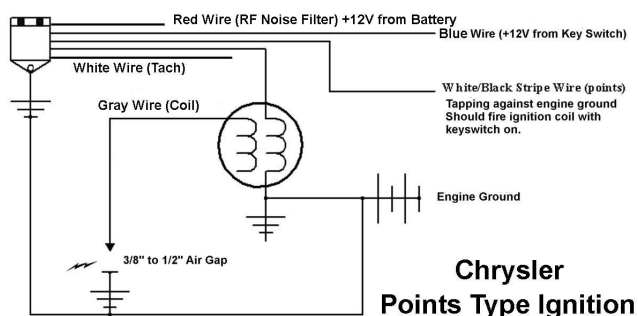

(NOTE) Preamps are an electronic version of points and the ignition module will test the same for both.

4. Check the DC voltage present on the Blue wire at cranking. It MUST be at least 9.5 volts. If not, the problem is likely in the harness, key switch, starter or battery.
5. Connect a DC voltmeter to the White/Black wire (while it is connected to the distributor) and slowly rotate the engine. There should be some fluctuation in the meter reading. If the reading is high, and fails to move up and down, there is definitely a problem inside the distributor. If the reading is low, disconnect the White/Black wire from the distributor and with the key switch turned on, strike the White/Black wire against engine ground. The unit should spark each time. If it does, then the CD module is usually good and the points (or Preamp) require checking. If the CD module fails to spark with this test, then the CD module is usually bad.
6. Check DVA voltage on the Gray wire while connected to the coil, it should be approximately 200 volts at cranking. If the voltage is correct, replace the coil with another coil and retest or use a load resistor if another coil is not available. A coil that is shorted internally will give a low reading. In this case replace the coil and retry.

## Chrysler/Force Troubleshooting

After repairing the engine, check the battery voltage at approximately 3500 RPM, The MAXIMUM allowable voltage reading is 15.5 volts and the minimum is 12V. Running below 12V or over 15.5 volts may damage the ignition. Check for loose connections or a bad battery.

### Chrysler/Force Two Cylinder Engines using Combination CD Module with Built-in Ignition Coils (1978-1988)

#### NO SPARK OR INTERMITTENT SPARK ON ONE CYLINDER:

1. Check the Brown stop wires. They MUST be separated from each other. THIS SYSTEM SHORTS THE BROWN WIRES TOGETHER TO STOP THE ENGINE. The common practice of connecting the stop wires together and shorting them to ground in order to stop the engine will not work on this engine. Disconnect the Brown stop wires and retest. If you have spark, check the ignition switch's "M" terminals if using remote start. You should have a White wire on one terminal and a Blue wire on the other terminal. If both the Blue and White wires are connected together, correct the wiring. If the engine has a tiller handle, check the push button stop switch.

2. Check the stator and trigger resistance and DVA voltage as follows:

| WIRE                | READ TO               | OEM Ohms | CDI Ohms | DVA                 |
|---------------------|-----------------------|----------|----------|---------------------|
| Brown/Blue or Blue* | Brown/Yellow or Blue* | 680-900  | 250-350  | 180-400 V Connected |
| Brown/Blue          | Engine GND            | Open     | Open     | < 2 V Disconnected  |
| Brown/Yellow        | Engine GND            | Open     | Open     | < 2 V Disconnected  |
| Orange              | Green                 | 45-55    | 45-55    | 0.5 V + Connected   |
| Red                 | White/Green           | 45-55    | 45-55    | 0.5 V + Connected   |

NOTE: Some OEM stators had 2 Blue wires instead of the Blue and yellow wires more commonly used.

3. If readings are good and the #2 cylinder is the one not firing, swap the Red and White/Green trigger wires. If both cylinders now have spark, the trigger is not wired for this engine. However, you may leave the wires as they are and the engine will be run normally.
4. Disconnect the stop wire from one pack. If that cylinder starts firing, the stop circuit in the harness or on the boat is bad, possibly the ignition switch.
5. If readings are good, disconnect stop wire from one pack. If the dead cylinder starts sparking, the problem is likely the blocking diode in the opposite pack.

#### ENGINE WILL NOT SHUT OFF:

Disconnect the Brown stop wires. Connect a jumper wire to ONE of the stop wires from the pack and short it to engine ground. If this stops the pack from sparking, the stop circuit has a fault. Check the key switch, harness and shift switch. If this does not stop the pack from sparking, replace the pack.

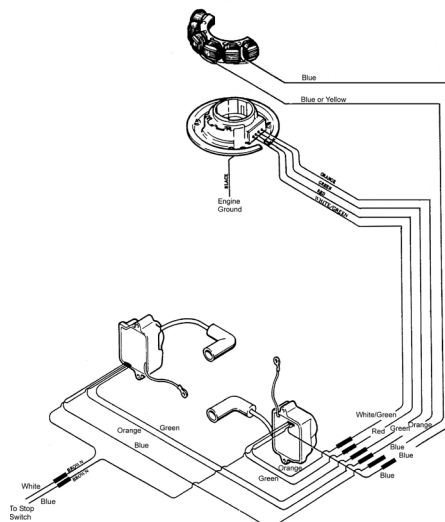

## **Chrysler/Force Troubleshooting**

### **Chrysler/Force Prestolite ADI Ignitions 1984-1992 General Troubleshooting**

1. Disconnect the stop wires from the CD. Measure DC voltage from the stop wires (from the harness) to engine ground. Turn the ignition switch on and off several times. DC voltage should never exceed 2V. If it does, the stop circuit has a fault. Check the key switch, harness and shift switch.
2. Check the flywheel for a broken or loose magnet.
3. Check for broken wires and terminals, especially inside the plastic plug-in connectors. We recommend that you remove the pins from the connectors using the CDI 511-9706 pin removal tool and visually inspect them.
4. Visually inspect stator for burned or discolored areas. If found, replace the stator. If the areas are on the battery charge windings, it indicates a possible problem with the rectifier.

#### **NO SPARK ON ANY CYLINDER:**

1. Disconnect the stop wire AT THE POWER PACK.
2. Disconnect the rectifier. If the engine sparks, replace the rectifier.
3. Check for broken or bare wires on the CD Module, stator and trigger.
4. Check the stator and trigger resistance and DVA voltage as follows:

| WIRE    | READ TO     | OEM OHMS | CDI OHMS | DVA                   |
|---------|-------------|----------|----------|-----------------------|
| Blue    | Yellow      | 680-900  | 250-350  | 180-400 V (Connected) |
| Blue    | Engine GND  | Open     | Open     | < 2 V (Disconnected)  |
| Yellow  | Engine GND  | Open     | Open     | < 2 V (Disconnected)  |
| Orange) | Green       | 45-55    | 45-55    | 0.5 V + (Connected)   |
| Red     | White/Green | 45-55    | 45-55    | 0.5 V + (Connected)   |

(NOTE) Remember that the stator may use Brown/Yellow or Brown/Black/Yellow for Yellow and Brown/Blue or Brown/Black/Blue for Blue.

- A. The DVA reading to engine ground is checking a circuit inside the power pack. If the readings are not fairly equal, swap the stator wires going to the power pack and recheck. If the low reading stays on the same wire from the stator, replace the stator. Otherwise, replace the power pack.
- B. Most meters will pick up a small amount of voltage due to inductive pick-up. As long as the voltage is very low, it will not indicate a problem.

#### **NO SPARK OR INTERMITTENT SPARK ON ONE CYLINDER:**

1. Check the stator and trigger resistance and DVA voltage (see NO SPARK ON ANY CYLINDER above).
2. If readings are good, disconnect stop wire from one pack. If the dead cylinder starts sparking, the problem is likely the blocking diode in the opposite pack.

#### **POWER PACK OR TRIGGER REPEATEDLY BLOWS ON SAME CYLINDER:**

1. Check the trigger wires for shorts to engine ground as a shorted trigger wire can destroy a SCR inside the power pack.
2. In contrast, a shorted SCR inside the power pack can destroy a trigger coil. Check the trigger resistance and DVA output (see NO SPARK ON ANY CYLINDER above).
3. Replace the ignition coil on the cylinder dropping spark.

#### **NO SPARK ON TWO CYLINDERS:**

1. If two cylinders from the same CD unit will not spark, the problem is usually in the stator. Test per above.
2. If the engine has a CDI stator installed:
  - A. If #1 and #3 are the ones not firing, disconnect the Yellow stator wire from the # 1 pack and see if the #3 cylinder starts firing. If so, replace the #1 pack. If not, then reconnect the Yellow stator wire to the # 1 pack and disconnect the Yellow stator wire from the # 2 pack and see if the #1 cylinder starts firing. If so, replace the # 2 pack.
  - B. If #2 and #4 are the ones not firing, disconnect the Blue stator wire from the # 1 pack and see if the #4 cylinder starts firing. If so, replace the #1 pack. If not, then reconnect the Blue stator wire to the # 1 pack and disconnect the Blue stator wire from the # 2 pack and see if the #2 cylinder starts firing. If so, replace

## **Chrysler/Force Troubleshooting**

the # 2 pack.

### **ENGINE WILL NOT SHUT OFF:**

Disconnect all stop wires at the power pack. Connect a jumper wire to the stop wire from the pack and short it to engine ground. If this stops the pack from sparking, the stop circuit has a fault. Check the key switch, harness and shift switch. If this does not stop the pack from sparking, replace the power pack. Repeat test as necessary for additional packs.

### **COILS ONLY HAVE SPARK WITH SPARK PLUGS OUT:**

Check for dragging starter or low battery causing slow cranking speed. DVA test stator and trigger.

### **MISS AT ANY RPM:**

1. Disconnect the rectifier from the stator and retest. If the miss clears, replace the rectifier.
2. In the water or on a Dynameters, check the DVA output from the power pack outputs while connected to the ignition coils. You should have a reading of at least 150V DVA or more, increasing with engine RPM until it reaches 300-400V DVA maximum. A sharp drop in DVA right before the miss becomes apparent on all cylinders will normally be caused by a bad stator. A sharp drop in DVA on less than all cylinders will normally be the switch box or trigger.
3. Connect an inductive tachometer to each cylinder in turn and try to isolate the problem. A high variance in RPM on one cylinder usually indicates a problem in the switch box or ignition coil. Occasionally a trigger will cause this same problem. Check the trigger DVA voltage (see NO SPARK ON ANY CYLINDER above).
4. Perform a high-speed shutdown and read the spark plugs. Check for water. A crack in the block can cause a miss at high speed when the water pressure gets high, but a normal shutdown will mask the problem.
5. Check the triggering and charge coil flywheel magnets for cracked, broken and loose magnets.

**Chrysler/Force**

## **Chrysler/Force Prestolite ADI Ignitions 1984-1992 Two Cylinder Engines Using Separate Switch Boxes and Ignition Coils**

### **GENERAL:**

1. Disconnect the stop wires from the CD. Measure DC voltage from the stop wires (from the harness) to engine ground. Turn the ignition switch on and off several times. DC voltage should never exceed 2V. If it does, the stop circuit has a fault. Check the key switch, harness and shift switch.
2. Check the flywheel for a broken or loose magnet.
3. Check for broken wires and terminals, especially inside the plastic plug-in connectors. We recommend that you remove the pins from the connectors using the CDI 511-9706 pin removal tool and visually inspect them.
4. Visually inspect the stator for burned or discolored areas. If found, replace the stator. If the areas are on the battery charge windings, it indicates a possible problem with the rectifier.

### **NO SPARK ON ANY CYLINDER:**

1. Disconnect all stop wires AT THE POWER PACK.
2. Disconnect the rectifier. If the engine sparks, replace the rectifier.
3. Check for broken or bare wires on the switch box, stator and trigger.
4. Check the stator and trigger resistance and DVA voltage as follows:

| WIRE                     | READ TO                  | OEM OHMS | CDI OHMS | DVA                            |
|--------------------------|--------------------------|----------|----------|--------------------------------|
| Brown/Blue (or Blue)     | Brown/Yellow (or Yellow) | 680-900  | 250-350  | 180-400 V ( <u>Connected</u> ) |
| Brown/Blue (or Blue)     | Engine GND               | Open     | Open     | < 2 V ( <u>Disconnected</u> )  |
| Brown/Yellow (or Yellow) | Engine GND               | Open     | Open     | < 2 V ( <u>Disconnected</u> )  |
| White/Orange (or Orange) | White/Yellow (or Green)  | 45-55    | 45-55    | 0.5 V + ( <u>Connected</u> )   |
| White/Red (or Red)       | White/Green              | 45-55    | 45-55    | 0.5 V + ( <u>Connected</u> )   |

### **NO SPARK OR INTERMITTENT SPARK ON ONE CYLINDER:**

1. Check the stator and trigger resistance and DVA voltage (see NO SPARK ON ANY CYLINDER above).
2. If readings are good, swap the power pack output from the ignition coil that works to the one that does not. If the coil that had spark stops sparking, replace the power pack.



## **Chrysler/Force Troubleshooting**

### **POWER PACK OR TRIGGER REPEATEDLY BLOWS ON SAME CYLINDER:**

1. Check the trigger wires for shorts to engine ground as a shorted trigger wire can destroy a SCR inside the power pack.
2. In contrast, a shorted SCR inside the power pack can destroy a trigger coil. Check the trigger resistance and DVA output (see NO SPARK ON ANY CYLINDER above).
3. Replace the ignition coil on the cylinder dropping spark.

### **ENGINE WILL NOT SHUT OFF:**

Disconnect all stop wires at the power pack. Connect a jumper wire to the stop wire from the pack and short it to engine ground. If this stops the pack from firing, the stop circuit has a fault. Check the key switch, harness and shift switch. If this does not stop the pack from firing, replace the power pack. Repeat test as necessary for additional packs.

### **COILS ONLY HAVE SPARK WITH SPARK PLUGS OUT:**

Check for dragging starter or low battery causing slow cranking speed. DVA test stator and trigger.

### **MISS AT ANY RPM:**

1. Disconnect the rectifier from the stator and retest. If the miss clears, replace the rectifier.
2. In the water or on a Dynameters, check the DVA output from the power pack outputs while connected to the ignition coils. You should have a reading of at least 150V DVA or more, increasing with engine RPM until it reaches 300-400V DVA maximum. A sharp drop in DVA right before the miss becomes apparent on all cylinders will normally be caused by a bad stator. A sharp drop in DVA on less than all cylinders will normally be the switch box or trigger.
3. Connect an inductive tachometer to each cylinder in turn and try to isolate the problem. A high variance in RPM on one cylinder usually indicates a problem in the switch box or ignition coil. Occasionally a trigger will cause this same problem. Check the trigger DVA voltage (see NO SPARK ON ANY CYLINDER above).
4. Perform a high-speed shutdown and read the spark plugs. Check for water. A crack in the block can cause a miss at high speed when the water pressure gets high, but a normal shutdown will mask the problem.
5. Check the triggering and charge coil flywheel magnets for cracked, broken and loose magnets.

# Chrysler/Force Troubleshooting

## Connections

### Pack #1 (Firing #1 and #2 Cylinders)

|                                  |                                    |
|----------------------------------|------------------------------------|
| <b>Pack:</b> White/Org Stripe    | <b>Trigger:</b> White/Org Stripe   |
| White/Yellow                     | White/Yellow (a)                   |
| White/Red                        | White/Red (a)                      |
| White/Green Stripe               | White/Green Stripe                 |
| <b>Pack:</b> Brown/Yellow Stripe | <b>Stator:</b> Brown/Yellow Stripe |
| Brown/Blue Stripe                | Brown/Blue Stripe                  |
| <b>Pack:</b> Orange/Blue         | <b>Coil:</b> White                 |
| Blue/Red                         | White                              |

## Color Code Cross Reference

| FUNCTION      | OLD                | NEW                 |
|---------------|--------------------|---------------------|
| Trigger       | Orange             | White/Org Stripe    |
| Trigger       | Green              | White/Yellow Stripe |
| Trigger       | Red                | White/Red Stripe    |
| Trigger       | White/Green Stripe | White/Green Stripe  |
| Stator        | Blue               | Brown/Blue Stripe   |
| Stator        | Yellow             | Brown/Yellow Stripe |
| Ignition Coil | White              | Orange/Blue         |
| Stop Circuit  | White              | Black/Yellow        |

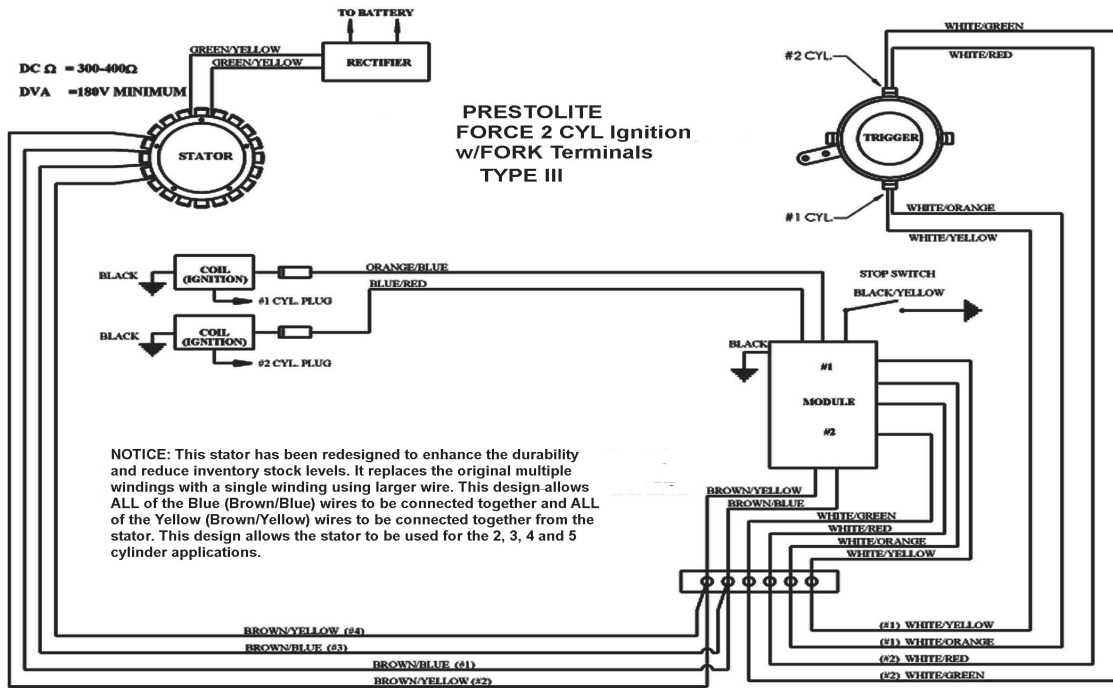

**Chrysler/Force**

## **Chrysler/Force Troubleshooting**

### **Chrysler/Force**

#### **Prestolite ADI Ignitions 1984-1992**

#### **Three and Four Cylinder Engines Using Separate Switch Boxes and Ignition Coils**

##### **NO SPARK ON ANY CYLINDER:**

1. Disconnect the stop wire AT THE POWER PACK.
2. Disconnect the rectifier. If the engine sparks, replace the rectifier.
3. Check for broken or bare wires on the unit, stator and trigger.
4. Check the stator and trigger resistance and DVA voltage as follows:

| <b>WIRE</b>              | <b>READ TO</b>           | <b>OEM OHMS</b> | <b>CDI OHMS</b> | <b>DVA</b>                    |
|--------------------------|--------------------------|-----------------|-----------------|-------------------------------|
| Brown/Blue (or Blue)     | Brown/Yellow (or Yellow) | 680-900         | 250-350         | 80-400 V ( <u>Connected</u> ) |
| Brown/Blue (or Blue)     | Engine GND               | Open            | Open            | < 2 V ( <u>Disconnected</u> ) |
| Brown/Yellow (or Yellow) | Engine GND               | Open            | Open            | < 2 V ( <u>Disconnected</u> ) |
| White/Orange (or Orange) | White/Yellow (or Green)  | 45-55           | 45-55           | 0.5 V + ( <u>Connected</u> )  |
| White/Red (or Red)       | White/Green              | 45-55           | 45-55           | 0.5 V + ( <u>Connected</u> )  |

##### **NO SPARK OR INTERMITTENT SPARK ON ONE CYLINDER:**

1. Check the stator and trigger resistance and DVA voltage (see NO SPARK ON ANY CYLINDER above).
2. If readings are good, disconnect stop wire from one pack. If the dead cylinder starts sparking, the problem is likely the blocking diode in the opposite pack.
3. If #2 on a three cylinder engine is the one not firing and the engine has a CDI stator installed, disconnect the Blue wire going to the #2 pack and see if the #2 cylinder starts firing. If so, reconnect the Blue wire with the Blue wire going to the #1 pack.

##### **POWER PACK OR TRIGGER REPEATEDLY BLOWS ON SAME CYLINDER:**

1. Check the trigger wires for shorts to engine ground as a shorted trigger wire can destroy a SCR inside the power pack.
2. In contrast, a shorted SCR inside the power pack can destroy a trigger coil. Check the trigger resistance and DVA output (see NO SPARK ON ANY CYLINDER above).
3. Replace the ignition coil on the cylinder dropping spark.

##### **NO SPARK ON TWO CYLINDERS:**

1. If two cylinders from the same CD unit will not spark, the problem is usually in the stator. Test per above.
2. If the engine has a CDI stator installed:
  - A. If #1 and #3 are the ones not firing, disconnect the Yellow stator wire from the # 1 pack and see if the #3 cylinder starts firing. If so, replace the #1 pack. If not, then reconnect the Yellow stator wire to the # 1 pack and disconnect the Yellow stator wire from the # 2 pack and see if the #1 cylinder starts firing. If so, replace the # 2 pack.
  - B. If #2 and #4 are the ones not firing, disconnect the Blue stator wire from the # 1 pack and see if the #4 cylinder starts firing. If so, replace the #1 pack. If not, then reconnect the Blue stator wire to the # 1 pack and disconnect the Blue stator wire from the # 2 pack and see if the #2 cylinder starts firing. If so, replace the # 2 pack.

##### **ENGINE WILL NOT SHUT OFF:**

Disconnect all stop wires at the power pack. Connect a jumper wire to the stop wire from the pack and short it to engine ground. If this stops the pack from sparking, the stop circuit has a fault. Check the key switch, harness and shift switch. If this does not stop the pack from sparking, replace the power pack. Repeat test as necessary for additional packs.

##### **COILS ONLY HAVE SPARK WITH SPARK PLUGS OUT:**

Check for dragging starter or low battery causing slow cranking speed. DVA test stator and trigger.

## Chrysler/Force Troubleshooting

### MISS AT ANY RPM:

1. Disconnect the rectifier from the stator and retest. If the miss clears, replace the rectifier.
2. In the water or on a Dynameters, check the DVA output from the power pack outputs while connected to the ignition coils. You should have a reading of at least 150V DVA or more, increasing with engine RPM until it reaches 300-400V DVA maximum. A sharp drop in DVA right before the miss becomes apparent on all cylinders will normally be caused by a bad stator. A sharp drop in DVA on less than all cylinders will normally be the switch box or trigger.
3. Connect an inductive tachometer to each cylinder in turn and try to isolate the problem. A high variance in RPM on one cylinder usually indicates a problem in the switch box or ignition coil. Occasionally a trigger will cause this same problem. Check the trigger DVA voltage (see NO SPARK ON ANY CYLINDER above).
4. Perform a high-speed shutdown and read the spark plugs. Check for water. A crack in the block can cause a miss at high speed when the water pressure gets high, but a normal shutdown will mask the problem.
5. Check the triggering and charge coil flywheel magnets for cracked, broken and loose magnets.

### CONNECTION GUIDE

|  |  |   |   |
|--|--|---|---|
| <b>Pack #1 (Firing #1 and #2 Cylinders)</b>  |  | <b>Pack #2 (Firing #3 and #4 Cylinders on a 4 Cylinder engine)</b>                  |   |
| <b>Pack:</b> White/Orange Stripe<br>White/Orange Stripe<br>White/Yellow<br>White/Red<br>White/Green Stripe | <b>Trigger:</b> White/Orange Stripe<br>White/Yellow (a)<br>White/Red (a)<br>White/Green Stripe | <b>Pack:</b> White/Orange Stripe<br>White/Yellow<br>White/Red<br>White/Green Stripe | <b>Trigger:</b> White/Yellow (a)<br>White/Red (a)<br>White/Green Stripe |
| <b>Pack:</b> Brown/Yellow Stripe<br>Brown/Blue Stripe  | <b>Stator:</b> Brown/Yellow Stripe<br>Brown/Blue Stripe  | <b>Pack:</b> Brown/Yellow Stripe<br>Brown/Blue Stripe                               | <b>Stator:</b> Brown/Yellow Stripe<br>Brown/Blue Stripe                 |
| <b>Pack:</b> Orange/Blue<br>Blue/Red   | <b>Coil:</b> White<br>White  | <b>Pack:</b> Orange/Blue<br>Blue/Red  | <b>Coil:</b> White<br>White   |

|   |  |
|---|--|
| <b>Pack #2 (Firing #3 Cylinder)</b>   |  |
| <b>Pack:</b> White/Orange Stripe<br>White/Yellow<br>White/Red<br>White/Green Stripe | <b>Trigger:</b> White/Orange Stripe<br>White/Yellow (a)<br>No Connection<br>No Connection              |
| <b>Pack:</b> Brown/Yellow Stripe<br>Brown/Blue                                      | <b>Stator:</b> Brown/Yellow Stripe<br>No Connection (must be connected to the blue terminal on pack 1) |
| <b>Pack:</b> Orange/Blue<br>Blue/Red  | <b>Coil:</b> White<br>No Connection  |

(a) CDI replacement triggers do not have a connection for this wire from the power pack as the new trigger uses a common ground wire. This allows the wires going to the power pack from the trigger to be larger and more durable. The power pack uses that color as a ground wire for the trigger.

### Color Code Cross Reference

| FUNCTION            | OLD                | NEW                 | FUNCTION            | OLD    | NEW                 |
|---------------------|--------------------|---------------------|---------------------|--------|---------------------|
| Trigger             | Orange             | White/Orange Stripe | Stator              | Blue   | Brown/Blue Stripe   |
| Trigger             | Green              | White/Yellow Stripe | Stator              | Yellow | Brown/Yellow Stripe |
| Trigger             | Red                | White/Red Stripe    | Ignition Coil       | White  | Orange/Blue         |
| Trigger             | White/Green Stripe | White/Green Stripe  | Stop Circuit        | White  | Black/Yellow        |
| Pack Output to Coil | Orange             | Orange/Blue         | Pack Output to Coil | Red    | Blue/Red            |





# Chrysler/Force Troubleshooting

## Chrysler/Force

### Prestolite ADI Ignitions 1989-1992

#### Five Cylinder Engine Using Separate Switch Boxes and Ignition Coils

**NO SPARK ON ANY CYLINDER:**

1. Disconnect the stop wire AT THE POWER PACK.
2. Disconnect the rectifier. If the engine now has spark, replace the rectifier.
3. Check for broken or bare wires on the CD Modules, stator and trigger.
4. Check the stator and trigger resistance and DVA voltage as follows:

| WIRE                     | READ TO                  | OEM OHMS | CDI OHMS | DVA                   |
|--------------------------|--------------------------|----------|----------|-----------------------|
| Brown/Blue (or Blue)     | Brown/Yellow (or Yellow) | 680-900  | 250-350  | 180-400 V (Connected) |
| Brown/Blue (or Blue)     | Engine GND               | Open     | Open     | < 2 V (Disconnected)  |
| Brown/Yellow (or Yellow) | Engine GND               | Open     | Open     | < 2 V (Disconnected)  |
| White/Orange (or Orange) | White/Yellow (or Green)  | 45-55    | 45-55    | 0.5 V + (Connected)   |
| White/Red (or Red)       | White/Green              | 45-55    | 45-55    | 0.5 V + (Connected)   |

(NOTE) Remember that the stator may use Brown/Yellow or Brown/Black/Yellow for Yellow and Brown/Blue or Brown/Black/Blue for Blue.

- A. The DVA reading to engine ground is checking a circuit inside the power pack. If the readings are not fairly equal, swap the stator wires going to the power pack and recheck. If the low reading stays on the same wire from the stator, replace the stator. Otherwise, replace the power pack.
- B. Most meters will pick up a small amount of voltage due to inductive pick-up. As long as the voltage is very low, it will not indicate a problem.

**NO SPARK OR INTERMITTENT SPARK ON ONE CYLINDER:**

1. Check the stator and trigger resistance; the trigger wire sets should read approximately 50 ohms between the wire sets (DVA-.5V or more), the stator should read 680-800 ohms (factory) and 250-350 ohms (CDI) DVA 180-400V from Blue to Yellow.
2. If readings are good, disconnect stop wire from one pack. If the dead cylinder starts sparking, the problem is likely the blocking diode in the pack you disconnected.

**POWER PACK OR TRIGGER REPEATEDLY BLOWS ON SAME CYLINDER:**

1. Check the trigger wires for shorts to engine ground as a shorted trigger wire can destroy a SCR inside the power pack.
2. In contrast, a shorted SCR inside the power pack can destroy a trigger coil. Check the trigger resistance and DVA output (see NO SPARK ON ANY CYLINDER above).
3. Replace the ignition coil on the cylinder dropping spark.

**NO SPARK ON TWO OR THREE CYLINDERS:**

1. If two cylinders from the same CD unit will not spark, the problem is usually in the stator. Test per above.
2. If the engine has a CDI stator installed:
  - A. If #1, #3 and #5 are the ones not firing, disconnect the Yellow stator wire from the # 1 pack and see if the #3 and #5 cylinders start firing. Is so, replace the #1 pack. If not, then reconnect the Yellow stator wire to the # 1 pack and disconnect the Yellow stator wire from the # 2 pack and see if the #1 and #5 cylinders start firing. If so, replace the # 2 pack. If not, then reconnect the Yellow stator wire to the # 2 pack and disconnect the Yellow stator wire from the #3 pack and see if the #1 and #3 cylinders start firing. If so, replace the # 3 pack.
  - B. If #2 and #4 are the ones not firing, disconnect the Blue stator wire from the # 1 pack and see if the #4 cylinder starts firing. Is so, replace the #1 pack. If not, then reconnect the Blue stator wire to the # 1 pack and disconnect the Blue stator wire from the # 2 pack and see if the #2 cylinder starts firing. If so, replace the # 2 pack.

**ENGINE WILL NOT SHUT OFF:**

Disconnect all stop wires at the power pack. Connect a jumper wire to the stop wire from the pack and short it to engine ground. If this stops the pack from sparking, the stop circuit has a fault. Check the key switch, harness and shift switch. If this does not stop the pack from sparking, replace the power pack. Repeat test as necessary for additional packs.

## Chrysler/Force Troubleshooting

### COILS ONLY HAVE SPARK WITH SPARK PLUGS OUT:

Check for dragging starter or low battery causing slow cranking speed. DVA test stator and trigger.

### MISS AT ANY RPM:

1. Disconnect the rectifier from the stator and retest. If the miss clears, replace the rectifier.
2. In the water or on a Dynameters, check the DVA output from the power pack outputs while connected to the ignition coils. You should have a reading of at least 150V DVA or more, increasing with engine RPM until it reaches 300-400V DVA maximum. A sharp drop in DVA right before the miss becomes apparent on all cylinders will normally be caused by a bad stator. A sharp drop in DVA on less than all cylinders will normally be the switch box or trigger.
3. Connect an inductive tachometer to each cylinder in turn and try to isolate the problem. A high variance in RPM on one cylinder usually indicates a problem in the switch box or ignition coil. Occasionally a trigger will cause this same problem. Check the trigger DVA voltage (see NO SPARK ON ANY CYLINDER above).
4. Perform a high-speed shutdown and read the spark plugs. Check for water. A crack in the block can cause a miss at high speed when the water pressure gets high, but a normal shutdown will mask the problem.
5. Check the triggering and charge coil flywheel magnets for cracked, broken and loose magnets.

### Connections: 5 Cylinder

| Pack #1 (Firing #1 and #2 Cylinders) |                    |                 |                     | Pack #3 (Firing #4 and #5 Cylinders) |                     |                 |                   |
|--------------------------------------|--------------------|-----------------|---------------------|--------------------------------------|---------------------|-----------------|-------------------|
| <b>Pack:</b>                         | White/Org Stripe   | <b>Trigger:</b> | White/Org Stripe    | <b>Pack:</b>                         | White/Org Stripe    | <b>Trigger:</b> | White/Org Stripe  |
|                                      | White/Yellow       |                 | White/Yellow (a)    |                                      | White/Yellow        |                 | White/Yellow (a)  |
|                                      | White/Red          |                 | White/Red (a)       |                                      | White/Red           |                 | White/Red (a)     |
|                                      | White/Green Stripe |                 | White/Green Stripe  |                                      | White/Green Stripe  |                 | White/Green Strip |
| <b>Pack:</b>                         | Brown/Yel Stripe   | <b>Stator:</b>  | Brown/Yellow Stripe | <b>Pack:</b>                         | Brown/Yellow Stripe | <b>Stator:</b>  | Brown/Yellow Stri |
|                                      | Brown/Blue Stripe  |                 | Brown/Blue Stripe   |                                      | Brown/Blue Stripe   |                 | Brown/Blue Stripe |
| <b>Pack:</b>                         | Orange/Blue        | <b>Coil:</b>    | White               | <b>Pack:</b>                         | Orange/Blue         | <b>Coil:</b>    | White             |
|                                      | Blue/Red           |                 | White               |                                      | Blue/Red            |                 | White             |

### Pack #2 (Firing #3 Cylinder)

|              |                     |                 |   |
|--------------|---------------------|-----------------|---|
| <b>Pack:</b> | White/Orange Stripe | <b>Trigger:</b> | White/Orange Stripe   |
|              | White/Yellow        |                 | White/Yellow (a)  |
|              | White/Red           |                 | No Connection   |
|              | White/Green Stripe  |                 | No Connection   |
| <b>Pack:</b> | Brown/Yellow Stripe | <b>Stator:</b>  | Brown/Yellow Stripe   |
|              | No Connection       |                 | Blue (may be connected to the blue terminal on pack 1 or 2) |
| <b>Pack:</b> | Orange/Blue         | <b>Coil: #3</b> | White   |
|              | Blue /Red           |                 | No Connection   |

(a) CDI replacement triggers do not have a connection for this wire from the power pack as the new trigger uses a common ground wire. This allows the wires going to the power pack from the trigger to be larger and more durable. The power pack uses that color as a ground wire for the trigger.

### Color Code Cross Reference

| FUNCTION            | OLD                 | NEW                 | FUNCTION                   | OLD    | NEW              |
|---------------------|---------------------|---------------------|----------------------------|--------|------------------|
| Trigger             | Orange              | White/Orange Stripe | Stator                     | Blue   | Brown/Blue Strig |
| Trigger             | Green               | White/Yellow Stripe | Stator                     | Yellow | Brown/Yellow St  |
| Trigger             | Red                 | White/Red Stripe    | Ignition Coil              | White  | Orange/Blue      |
| Trigger             | White/Green Stripes | White/Green Stripes | Stop Circuit               | White  | Black/Yellow     |
| Pack Output to Coil | Orange              | Orange/Blue         | Pack Output to <u>Coil</u> | Red    | Blue/Red         |

# Chrysler/Force Troubleshooting

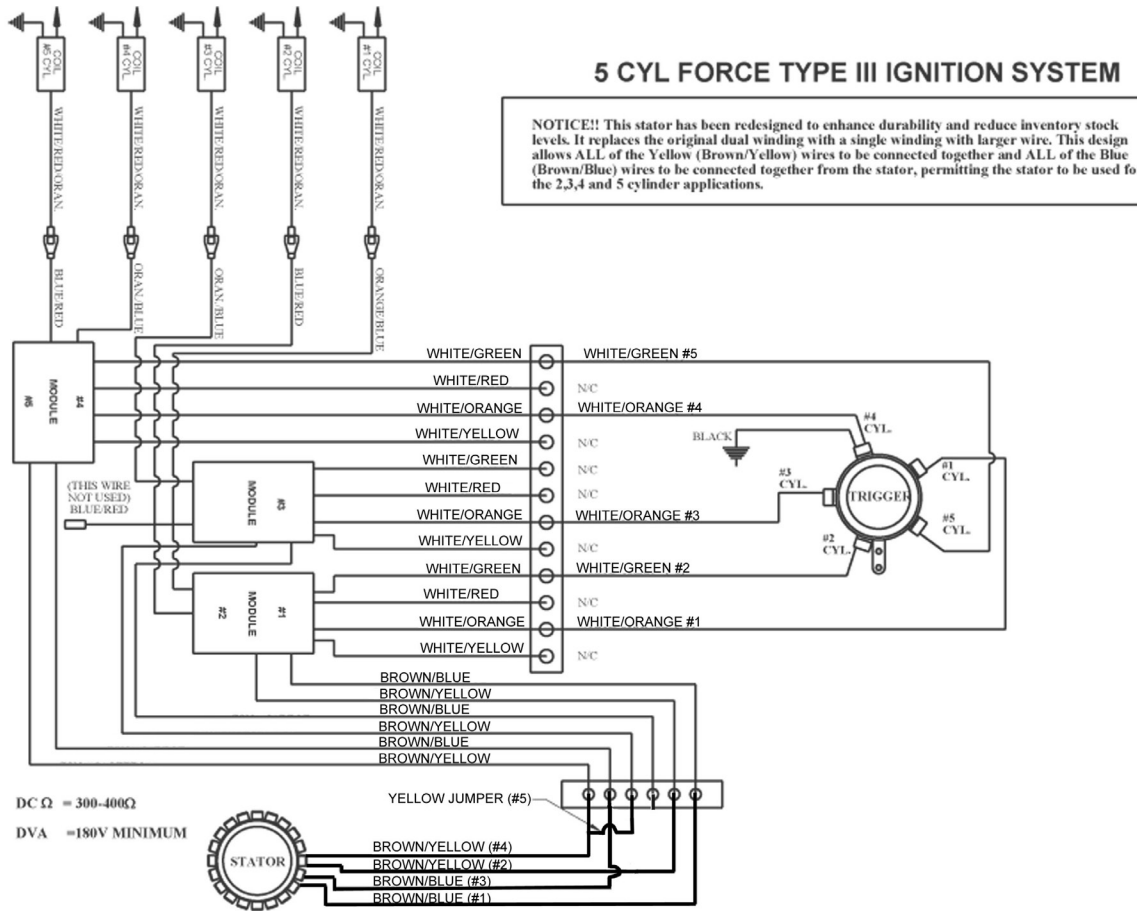

## Force

### Mercury Designed Ignitions 1991-1996

#### Two Cylinder Engines using a Separate Switch Box and Two Ignition Coils

#### NO SPARK ON ANY CYLINDER:

1. Disconnect the Black/Yellow stop wire AT THE POWER PACK and retest. If the engine's ignition sparks, the stop circuit has a fault. Check the key switch, harness and shift switch.
2. Disconnect the Yellow wires from the stator to the rectifier and retest. If the engine now has spark, replace the rectifier.
3. Check the cranking RPM. A cranking speed of less than 250-RPM will not allow the system to spark properly. This can be caused by a weak battery, dragging starter, bad battery cables or a mechanical problem inside the engine.
4. Inspect and clean all engine and ignition ground connections.
5. Check the stator resistance and DVA output as follows:

#### Black Stator

| WIRE | READ TO    | OEM RESISTANCE | CDI RESISTANCE | DVA (Connected) | DVA (Disconnected) |
|------|------------|----------------|----------------|-----------------|--------------------|
| Blue | Blue/White | 3250-3650      | 488-662        | 180-400 V       | 180-400 V (*)      |
| Red  | Red/White  | 75-90          | 28-32          | 25-100 V        | 25-100 V (*)       |

#### Red Stator Kit

| WIRE        | READ TO     | OEM RESISTANCE | CDI RESISTANCE | DVA (Connected) | DVA (Disconnected) |
|-------------|-------------|----------------|----------------|-----------------|--------------------|
| White/Green | Green/White | 500-700        | 400-550        | 180-400 V       | 180-400 V (*)      |
| Blue        | Engine GND  | OPEN           | OPEN           | 180-400 V       | 180-400 V (*)      |

(\*) This reading can be used to determine if a stator or pack has a problem. For instance, if you have no spark on any cylinder and the stator's DVA reading is low – disconnect the stator wires and recheck the DVA output. If the reading stays low – the stator is bad. If the reading is now within spec – the pack is bad.

## **Chrysler/Force Troubleshooting**

6. Check the triggering and charge coil flywheel magnets for cracked, broken and loose magnets.

### **NO SPARK OR INTERMITTENT SPARK ON ONE CYLINDER:**

1. Check the trigger resistance and DVA output as shown below:

| WIRE   | READ TO    | RESISTANCE | DVA (Connected) | DVA (Disconnected) |
|--------|------------|------------|-----------------|--------------------|
| Purple | White      | 800-1400   | 4 V +           | 4 V + (#)          |
| Purple | Engine GND | Open       | 1 V +           | N/A                |
| White  | Engine GND | Open       | 1 V +           | N/A                |

(#) This reading can be used to determine if a pack has a problem in the triggering circuit. For instance, if you have no spark on one cylinder and the trigger's DVA reading for that cylinder is low – disconnect the trigger wires and recheck the DVA output. If the reading stays low – the trigger is bad. If the reading is now within spec – the pack is bad.

2. Check the DVA output on the Green wires from the switch box while connected to the ignition coils. Check the reading on the switch box terminal AND on the ignition coil terminal. You should have a reading of at least 150V or more (while connected) at both places. If the reading is low on one cylinder, disconnect the Green wire from the ignition coil for that cylinder and reconnect it to a load resistor. Retest. If the reading is now good, the ignition coil is likely bad. A continued low reading indicates a bad power pack.
3. If the cylinders are only misfiring above an idle, connect an inductive tachometer to each cylinder in turn and try to isolate the problem cylinder.
4. Visually inspect the ignition coils for burned or discolored areas and cracks in the casing (indicating arcing inside the coil).
5. Swap the ignition coil with one that is sparking correctly.
6. Rare causes include a weak trigger magnet. If possible, try another flywheel.

### **SWITCH BOX OR TRIGGER REPEATEDLY BLOWS ON SAME CYLINDER:**

1. Check the trigger wires for shorts to engine ground as a shorted trigger wire can destroy a SCR inside the switch box.
2. In contrast, a shorted SCR inside the switch box can destroy a trigger coil. Check the trigger resistance and DVA output (see NO SPARK OR INTERMITTENT SPARK ON ONE CYLINDER above).
3. Replace the ignition coil on the cylinder dropping spark.

### **ENGINE WILL NOT SHUT OFF:**

Disconnect the stop wire at the switch box. Connect a jumper wire to the stop wire from the switch box and short it to engine ground. If this stops the switch box from sparking, the stop circuit has a fault. Check the key switch, harness and shift switch. If this does not stop the switch box from sparking, replace the switch box. Repeat test as necessary for additional switch boxes.

### **WILL NOT ACCELERATE BEYOND 3000-4000 RPM:**

1. Disconnect the Yellow wires from the stator to the rectifier and retest. If the engine now has good spark, replace the rectifier.
2. Connect a DVA meter between the stator's Blue and Blue/White wires. Run the engine up to the RPM where the problem is occurring. DVA voltage should increase with RPM. A sharp drop in DVA right before the problem occurs usually indicates a bad stator. (Read from Blue to engine ground if the engine has a Red stator kit installed).
3. Connect a DVA meter between the stator's Red and Red/White wires. The DVA voltage should show a smooth climb in voltage and remain high through the RPM range. A reading lower than on the Blue wire reading indicates a bad stator.
4. Connect an inductive tachometer to each cylinder in turn and try to isolate the problem. A single cylinder dropping spark will likely be a bad switch box or ignition coil. All cylinders not sparking properly usually indicates a bad stator.
5. Perform a high-speed shutdown and read the spark plugs. Check for water. A crack in the block can cause a miss at high speed when the water pressure gets high, but a normal shutdown will mask the problem.
6. Check the triggering and charge coil flywheel magnets for cracked, broken and loose magnets.

### **MISS AT ANY RPM:**

1. Disconnect the Yellow wires from the stator to the rectifier and retest. If the miss clears, replace the rectifier.

## **Chrysler/Force Troubleshooting**

2. In the water or on a Dynameters, check the DVA output on the Green wires from the switch box while connected to the ignition coils. You should have a reading of at least 150V DVA or more, increasing with engine RPM until it reaches 300-400V DVA maximum. A sharp drop in DVA right before the miss becomes apparent on all cylinders will normally be caused by a bad stator. A sharp drop in DVA on less than all cylinders will normally be the switch box or trigger.
3. Connect an inductive tachometer to each cylinder in turn and try to isolate the problem. A high variance in RPM on one cylinder usually indicates a problem in the switch box or ignition coil. Occasionally a trigger will cause this same problem. Check the trigger DVA voltage (see NO SPARK OR INTERMITTENT SPARK ON ONE CYLINDER above).
4. Perform a high-speed shutdown and read the spark plugs. Check for water. A crack in the block can cause a miss at high speed when the water pressure gets high, but a normal shutdown will mask the problem.
5. Check the triggering and charge coil flywheel magnets for cracked, broken and loose magnets.
6. Rotate the stator one bolt hole in either direction and retest.

### **Force**

#### **Mercury Designed Ignitions 1991-1996**

#### **Three Cylinder Engines using a Single Switch Box and Three Ignition Coils**

##### **NO SPARK ON ANY CYLINDER:**

1. Disconnect the Black/Yellow stop wire AT THE POWER PACK and retest. If the engine's ignition sparks, the stop circuit has a fault. Check the key switch, harness and shift switch.
2. Disconnect the Yellow wires from the stator to the rectifier and retest. If the engine now has spark, replace the rectifier.
3. Check the cranking RPM. A cranking speed of less than 250-RPM will not allow the system to spark properly. This can be caused by a weak battery, dragging starter, bad battery cables or a mechanical problem inside the engine.
4. Inspect and clean all engine and ignition ground connections.
5. Check the stator resistance and DVA output as follows:

##### **Black Stator**

| WIRE | READ TO    | OEM OHMs  | CDI Ohms | DVA (Connected) | DVA (Disconnected) |
|------|------------|-----------|----------|-----------------|--------------------|
| Blue | Engine GND | 3250-3650 | 488-662  | 180-400 V       | 180-400 V (*)      |
| Red  | Engine GND | 75-90     | 28-32    | 25-100 V        | 25-100 V (*)       |

##### **Red Stator Kit**

| WIRE        | READ TO     | OEM OHMs | CDI Ohms | DVA (Connected) | DVA (Disconnected) |
|-------------|-------------|----------|----------|-----------------|--------------------|
| White/Green | Green/White | 500-700  | 400-550  | 180-400 V       | 180-400 V (*)      |
| Blue        | Engine GND  | OPEN     | OPEN     | 180-400 V       | 180-400 V (*)      |

(\*) This reading can be used to determine if a stator or pack has a problem. For instance, if you have no spark on any cylinder and the stator's DVA reading is low – disconnect the stator wires and recheck the DVA output. If the reading stays low – the stator is bad. If the reading is now within spec – the pack is bad.

6. Verify the correct flywheel is installed. The flywheel trigger magnet should NOT have the slots in the steel band.
7. Check the triggering and charge coil flywheel magnets for cracked, broken and loose magnets.

##### **NO SPARK OR INTERMITTENT SPARK ON ONE OR MORE CYLINDERS:**

1. Check the trigger resistance and DVA output as shown below:

| WIRE   | READ TO     | RESISTANCE | DVA (Connected) | DVA (Disconnected) |
|--------|-------------|------------|-----------------|--------------------|
| Brown  | White/Black | 800-1400   | 4 V +           | 4 V + (#)          |
| White  | White/Black | 800-1400   | 4 V +           | 4 V + (#)          |
| Purple | White/Black | 800-1400   | 4 V +           | 4 V + (#)          |
| Brown  | Engine GND  | Open       | 1 V +           | N/A                |
| White  | Engine GND  | Open       | 1 V +           | N/A                |
| Purple | Engine GND  | Open       | 1 V +           | N/A                |

(#) This reading can be used to determine if a pack has a problem in the triggering circuit. For instance, if you have no spark on one cylinder and the trigger's DVA reading for that cylinder is low—disconnect the trigger wires and recheck the DVA output. If the reading stays low the trigger is bad. If the reading is now within spec the pack is bad.



## **Chrysler/Force Troubleshooting**

2. Check the DVA output on the Green wires from the switch box while connected to the ignition coils. Check the reading on the switch box terminal AND on the ignition coil terminal. You should have a reading of at least 150V or more (while connected) at both places. If the reading is low on one cylinder, disconnect the green wire from the ignition coil for that cylinder and reconnect it to a load resistor. Retest. If the reading is now good, the ignition coil is likely bad. A continued low reading indicates a bad power pack.
3. If the cylinders are only misfiring above an idle, connect an inductive tachometer to each cylinder in turn and try to isolate the problem cylinder.
4. Visually inspect the ignition coils for burned or discolored areas and cracks in the casing (indicating arcing inside the coil).
5. Swap the ignition coil with one that is sparking correctly.
6. Rare causes include a weak trigger magnet. If possible, try another flywheel.

### **ENGINE HAS FIRE ON ALL CYLINDERS BUT WILL NOT RUN:**

1. Index the flywheel by bringing each piston to TDC (Top Dead Center) and mark the flywheel at the timing pointer for that cylinder.
2. Connect the sparkplug high tension leads to a spark tester instead of the sparkplugs. Using a timing light, check the timing on each cylinder, top to bottom. You should see the mark for #1 (Top cylinder) flashing close to the pointer when you are connected to the top sparkplug lead. Repeat for the #2 (Middle) cylinder and the #3 (Bottom) cylinder.
3. If you see a different cylinder number flashing than the one you are connected to, swap the Green wires between the #1 cylinder and the cylinder being displayed.
4. Repeat until all cylinders are firing in the correct order.

### **SWITCH BOX OR TRIGGER REPEATEDLY BLOWS ON SAME CYLINDER:**

1. Check the trigger wires for shorts to engine ground as a shorted trigger wire can destroy a SCR inside the switch box.
2. In contrast, a shorted SCR inside the switch box can destroy a trigger coil. Check the trigger resistance and DVA output (see NO SPARK ON ANY CYLINDER above).
3. Replace the ignition coil on the cylinder dropping spark.

### **ENGINE WILL NOT SHUT OFF:**

Disconnect the stop wire at the switch box. Connect a jumper wire to the stop wire from the switch box and short it to engine ground. If this stops the switch box from sparking, the stop circuit has a fault. Check the key switch, harness and shift switch. If this does not stop the switch box from sparking, replace the switch box. Repeat test as necessary for additional switch boxes.

### **WILL NOT ACCELERATE BEYOND 3000-4000 RPM:**

1. Disconnect the Yellow wires from the stator to the rectifier and retest. If the engine now has good spark, replace the rectifier.
2. Connect a DVA meter between the stator's Blue wire and engine ground. Run the engine up to the RPM where the problem is occurring. DVA voltage should increase with RPM. A sharp drop in DVA right before the problem occurs usually indicates a bad stator. (Read from Blue to engine ground if the engine has a Red stator kit installed).
3. Connect a DVA meter between the stator's Red wire and engine ground. The DVA voltage should show a smooth climb in voltage and remain high through the RPM range. A reading lower than on the Blue wire reading indicates a bad stator.
4. Connect an inductive tachometer to each cylinder in turn and try to isolate the problem. A single cylinder dropping spark will likely be a bad switch box or ignition coil. All cylinders not sparking properly usually indicates a bad stator.
5. Perform a high-speed shutdown and read the spark plugs. Check for water. A crack in the block can cause a miss at high speed when the water pressure gets high, but a normal shutdown will mask the problem.
6. Check the triggering and charge coil flywheel magnets for cracked, broken and loose magnets.

### **MISS AT ANY RPM:**

1. Disconnect the Yellow wires from the stator to the rectifier and retest. If the miss clears, replace the rectifier.
2. In the water or on a Dynameters, check the DVA output on the Green wires from the switch box while connected to the ignition coils. You should have a reading of at least 150V DVA or more, increasing with engine RPM until

## Chrysler/Force Troubleshooting

it reaches 300-400V DVA maximum. A sharp drop in DVA right before the miss becomes apparent on all cylinders will normally be caused by a bad stator. A sharp drop in DVA on less than all cylinders will normally be the switch box or trigger.

3. Connect an inductive tachometer to each cylinder in turn and try to isolate the problem. A high variance in RPM on one cylinder usually indicates a problem in the switch box or ignition coil. Occasionally a trigger will cause this same problem. Check the trigger DVA voltage (see NO SPARK OR INTERMITTENT SPARK ON ONE OR MORE CYLINDERS above).
4. Perform a high-speed shutdown and read the spark plugs. Check for water. A crack in the block can cause a miss at high speed when the water pressure gets high, but a normal shutdown will mask the problem.
5. Check the triggering and charge coil flywheel magnets for cracked, broken and loose magnets.
6. Rotate the stator one bolt hole in either direction and retest.

### Force

#### Mercury Designed Ignitions 1991-1998

#### Four Cylinder Engines using a Single Switch Box and Four Ignition Coils

##### NO SPARK ON ANY CYLINDER:

1. Disconnect the Black/Yellow stop wire AT THE POWER PACK and retest. If the engine's ignition sparks, the stop circuit has a fault. Check the key switch, harness and shift switch.
2. Disconnect the Yellow wires from the stator to the rectifier and retest. If the engine now has spark, replace the rectifier.
3. Check the cranking RPM. A cranking speed of less than 250-RPM will not allow the system to spark properly. This can be caused by a weak battery, dragging starter, bad battery cables or a mechanical problem inside the engine.
4. Inspect and clean all engine and ignition ground connections.
5. Check the stator resistance and DVA output where applicable:

##### Black Stator

| WIRE | READ       | OEM OHMs  | CDI Ohms | DVA (Connected) | DVA (Disconnected) |
|------|------------|-----------|----------|-----------------|--------------------|
| Blue | Blue/White | 3250-3650 | 488-662  | 180-400 V       | 180-400 V (*)      |
| Red  | Red/White  | 75-90     | 28-32    | 25-100 V        | 25-100 V (*)       |

##### Red Stator Kit

| WIRE        | READ TO     | OEM OHMS | CDI Ohms | DVA (Connected) | DVA (Disconnected) |
|-------------|-------------|----------|----------|-----------------|--------------------|
| White/Green | Green/White | 500-700  | 400-550  | 180-400 V       | 180-400 V (*)      |
| Blue        | Blue/White  | OPEN     | OPEN     | 180-400 V       | 180-400 V (*)      |

(\*) This reading can be used to determine if a stator or pack has a problem. For instance, if you have no spark on any cylinder and the stator's DVA reading is low – disconnect the stator wires and recheck the DVA output. If the reading stays low – the stator is bad. If the reading is now within spec – the pack is bad.

6. Check the triggering and charge coil flywheel magnets for cracked, broken and loose magnets.

##### NO SPARK OR INTERMITTENT SPARK ON ONE OR MORE CYLINDERS:

1. Check the trigger resistance and DVA output as shown below:

| WIRE        | READ TO     | RESISTANCE | DVA (Connected) | DVA (Disconnected) |
|-------------|-------------|------------|-----------------|--------------------|
| Purple      | White       | 800-1400   | 4 V +           | 4 V + (#)          |
| Brown       | White/Black | 800-1400   | 4 V +           | 4 V + (#)          |
| Purple      | Engine GND  | Open       | 1 V +           | N/A                |
| White       | Engine GND  | Open       | 1 V +           | N/A                |
| Brown       | Engine GND  | Open       | 1 V +           | N/A                |
| White/Black | Engine GND  | Open       | 1 V +           | N/A                |

(#) This reading can be used to determine if a pack has a problem in the triggering circuit. For instance, if you have no spark on one or two cylinders and the trigger's DVA reading for that cylinder is low – disconnect the trigger wires and recheck the DVA output. If the reading stays low – the trigger is bad. If the reading is now within spec – the pack is bad.

2. Check the DVA output on the Green wires from the switch box while connected to the ignition coils. Check the reading on the switch box terminal AND on the ignition coil terminal. You should have a reading of at least 150V

## **Chrysler/Force Troubleshooting**

or more (while connected) at both places. If the reading is low on one cylinder, disconnect the Green wire from the ignition coil for that cylinder and reconnect it to a load resistor. Retest. If the reading is now good, the ignition coil is likely bad. A continued low reading indicates a bad power pack.

3. If the cylinders are only misfiring above an idle, connect an inductive tachometer to each cylinder in turn and try to isolate the problem cylinder.
4. Visually inspect the ignition coils for burned or discolored areas and cracks in the casing (indicating arcing inside the coil).
5. Swap the ignition coil with one that is sparking correctly.
6. Rare causes include a weak trigger magnet. If possible, try another flywheel.

### **SWITCH BOX OR TRIGGER REPEATEDLY BLOWS ON SAME CYLINDER:**

1. Check the trigger wires for shorts to engine ground as a shorted trigger wire can destroy a SCR inside the switch box. At the same time, a shorted SCR inside the switch box can destroy a trigger coil. Check the trigger resistance and DVA output (see NO SPARK ON ANY CYLINDER above).
2. Replace the ignition coil on the cylinder dropping spark.

### **ENGINE WILL NOT SHUT OFF:**

Disconnect the stop wire at the switch box. Connect a jumper wire to the stop wire from the switch box and short it to engine ground. If this stops the switch box from sparking, the stop circuit has a fault. Check the key switch, harness and shift switch. If this does not stop the switch box from sparking, replace the switch box. Repeat test as necessary for additional switch boxes.

### **WILL NOT ACCELERATE BEYOND 3000-4000 RPM:**

1. Disconnect the Yellow wires from the stator to the rectifier and retest. If the engine now has good spark, replace the rectifier.
2. Connect a DVA meter between the stator's Blue and Blue/White wires. Run the engine up to the RPM where the problem is occurring. DVA voltage should increase with RPM. A sharp drop in DVA right before the problem occurs usually indicates a bad stator. (Read from Blue to engine ground if the engine has a Red stator kit installed).
3. Connect a DVA meter between the stator's Red and Red/White wires. The DVA voltage should show a smooth climb in voltage and remain high through the RPM range. A reading lower than on the Blue wire reading indicates a bad stator.
4. Connect an inductive tachometer to each cylinder in turn and try to isolate the problem. A single cylinder dropping spark will likely be a bad switch box or ignition coil. All cylinders not sparking properly usually indicates a bad stator.
5. Perform a high-speed shutdown and read the spark plugs. Check for water. A crack in the block can cause a miss at high speed when the water pressure gets high, but a normal shutdown will mask the problem.
6. Check the triggering and charge coil flywheel magnets for cracked, broken and loose magnets.

### **MISS AT ANY RPM:**

1. Disconnect the Yellow wires from the stator to the rectifier and retest. If the miss clears, replace the rectifier.
2. In the water or on a Dynameters, check the DVA output on the Green wires from the switch box while connected to the ignition coils. You should have a reading of at least 150V DVA or more, increasing with engine RPM until it reaches 300-400V DVA maximum. A sharp drop in DVA right before the miss becomes apparent on all cylinders will normally be caused by a bad stator. A sharp drop in DVA on less than all cylinders will normally be the switch box or trigger.
3. Connect an inductive tachometer to each cylinder in turn and try to isolate the problem. A high variance in RPM on one cylinder usually indicates a problem in the switch box or ignition coil. Occasionally a trigger will cause this same problem. Check the trigger DVA voltage (see NO SPARK OR INTERMITTENT SPARK ON ONE OR MORE CYLINDERS above).
4. Perform a high-speed shutdown and read the spark plugs. Check for water. A crack in the block can cause a miss at high speed when the water pressure gets high, but a normal shutdown will mask the problem.
5. Check the triggering and charge coil flywheel magnets for cracked, broken and loose magnets.
6. Rotate the stator one bolt hole in either direction and retest.

## **Chrysler/Force Troubleshooting**

### **Force**

#### **Five Cylinder Engines using a Single Switch Box (1991-1993)**

(NOTE) This engine uses a battery powered inverter box to provide 250V power to the switch box. The inverter is in a 332-4797 CD module case. This unit is easily identified as the inverter has four terminals instead of the seven used on the 332-4797 CD module. The original stator's only function is to charge the battery. CDI Electronics offers a replacement for the inverter (part# 176-4796K1), which combines the functions of the inverter box with the stator. The stator has a high voltage output in addition to the battery charging output, allowing the inverter box to be removed.

#### **NO SPARK ON ANY CYLINDER:**

1. Check the Red wire on the converter box from the battery at cranking; Minimum voltage is 9.5V.
2. Check the DVA voltage on the Purple/White terminal on the converter box at cranking. A minimum of 0.3V is needed to trigger the inverter box. If the voltage is low, check the DVA voltage from the White/Black trigger to the Yellow, Black, Brown, White and Purple trigger wires. If you read 4V or more, the inverter box is likely bad.
3. Check the DVA voltage on the Blue terminal on the converter box at cranking, reading should be approximately 250V.
4. CDI Electronics replacement stator only (part# 176-4796K1): Check the DVA output and resistance from the Blue wire to engine ground. You should read a minimum of 160V DVA and 80 ohms resistance.

#### **NO SPARK OR INTERMITTENT SPARK ON ONE OR MORE CYLINDERS:**

1. Check the DVA voltage from the White/Black trigger to the Yellow, Black, Brown, White and Purple trigger wires. If you read 4V or more, the trigger is likely good.
2. Check the DVA voltage from the switch box. You should have the same reading on all of the Green-striped output wires to the ignition coils. If one cylinder reads low, swap the locations of the Green-striped wire not firing with one that has spark. If the problem moves, replace the power pack. If the no spark condition remains on the same cylinder, replace the ignition coil.

#### **SWITCH BOX OR TRIGGER REPEATEDLY BLOWS ON SAME CYLINDER:**

1. Check the trigger wires for shorts to engine ground as a shorted trigger wire can destroy a SCR inside the power pack.
2. In contrast, a shorted SCR inside the power pack can destroy a trigger coil. Check the trigger resistance and DVA output (see NO SPARK ON ANY CYLINDER above).
3. Replace the ignition coil on the cylinder dropping spark.

#### **ENGINE WILL NOT SHUT OFF:**

Disconnect the stop wire at the switch box. Connect a jumper wire to the stop wire from the switch box and short it to engine ground. If this stops the switch box from sparking, the stop circuit has a fault. Check the key switch, harness and shift switch. If this does not stop the switch box from sparking, replace the switch box. Repeat test as necessary for additional switch boxes.

#### **ALL CYLINDERS HAVE SPARK, BUT ENGINE WILL NOT RUN:**

Disconnect the White/Black wire from the switch box and check the resistance from the switch box's White/Black wire to engine ground. The reading should be approximately 8400 ohms. A low reading indicates a bad bias circuit and the switch box needs to be replaced.

## Johnson/Evinrude Troubleshooting

### Johnson/Evinrude

#### Battery CD Ignitions with Points

#### 1968-1972 55, 60, 65, 85 and 100 HP Battery-Powered Models (With Points Ignition)

DUE TO THE CONSTRUCTION OF THE BATTERIES, DO NOT USE AUTOMOTIVE, MAINTAINENCE FREE OR LOW MAINTAINENCE BATTERIES FOR THIS APPLICATION! OVERCHARGING CAN CAUSE SEVERE DAMAGE TO THE IGNITION MODULE.

(NOTE) All clipper modules, surge suppressors and safety circuits should be removed. After removing, the ignition wire (Red or Purple) must be connected directly to the ignition switch terminal (providing 12V from ignition switch). BATTERY VOLTAGE TO THE POWER PACK MUST BE CONTROLLED TO A MAXIMUM OF 16 VOLTS!!! THE REGULATED RECTIFIER LIKE THE 193-0705 OR 193-3408 IS RECOMMENDED.

1. Clean all battery connections and engine grounds.
2. Check wiring as follows:

| Pack Wire Color | Function   |
|-----------------|--|
| Red or Purple   | 12V from key switch  |
| Blue            | Positive to ignition coil                                    |
| Black/White     | To points  |
| Black           | Engine Ground  |
| Not Used        | Gray Tach Wire (Connect with one of the Yellow stator wires) |

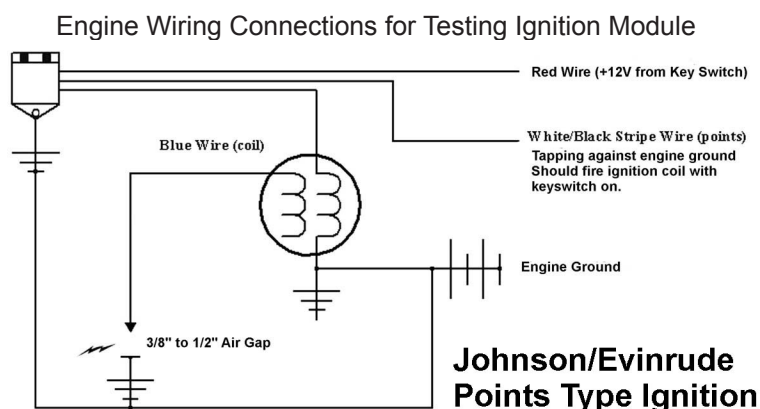

3. Connect a spark gap tester to the high tension lead coming from the ignition coil and set it to approximately  $\frac{1}{2}$ ".
4. Crank the engine over, if it sparks while the spark gap tester is connected to the coil and does not spark through the spark plug wires – there is a problem in the distributor cap, rotor button or spark plug wires.
5. Check DC voltage present on the Purple wire at cranking. It MUST be at least 9.5 volts. If not, there is a problem in the harness, key switch, starter or battery.
6. Check DVA voltage on the Blue wire going to the coil while connected, it should be approximately 200 volts at cranking.
7. Disconnect the White/Black points wire. Turn the ignition switch on and strike the White/Black points wire against engine ground. The unit should spark each time. If it does, this usually means the CD module is good. Check the points, points plate and grounding wire for the points.
8. Check the Anti-reverse spring around the crankshaft. Make sure it is not shorting out the points set.
9. Connect a spark gap tester to the high-tension leads coming from the distributor cap and set the gap to approximately  $\frac{7}{16}$ ". Align the rotor with #1 spark plug wire. Turn the ignition switch on and strike the White/Black points wire against engine ground. Only the #1 spark plug wire should spark. If another spark plug wire has spark, there is a problem in the distributor cap. Repeat the test for the other cylinders.
10. Check the battery voltage at approximately 3500-RPM, MAXIMUM reading allowable is 15.5 volts measured at the power pack. Over 15.5 volts will damage the ignition. Check for loose connections or a bad battery.

(NOTE) The CDI Electronics power pack may have a high pitched whine coming from it when the key switch is in the on position. This is normal and does not indicate a problem.



# Johnson/Evinrude Troubleshooting

## Johnson/Evinrude

### Prestolite Battery Ignitions with Pickup Sensor

#### 1968-1972 100, 115 and 125 HP Battery-Powered Models (Without Points Ignition)

**DUE TO THE CONSTRUCTION OF THE BATTERIES, DO NOT USE AUTOMOTIVE, MAINTAINENCE FREE OR LOW MAINTAINENCE BATTERIES FOR THIS APPLICATION! OVERCHARGING CAN CAUSE SEVERE DAMAGE TO THE IGNITION MODULE. The use of a regulated rectifier like the 193-3408 is recommended to help control the battery voltage.**

**(NOTE) All clipper modules, surge suppressors and safety circuits should be removed. After removing, the ignition wire (Red or Purple) must be connected directly to the ignition switch terminal (providing 12V from ignition switch).**

1. Clean all battery connections and engine grounds.
2. Check wiring as follows:

| Except 1967     |                           | 1967            |                           |
|-----------------|---------------------------|-----------------|---------------------------|
| Pack Wire Color | Function                  | Pack Wire Color | Function                  |
| Red or Purple   | 12V from key switch       | Red or Purple   | 12V from key switch       |
| Blue            | Positive to ignition coil | Green           | Positive to ignition coil |
| Black/White (2) | To trigger sensor         | Blue (2)        | To trigger sensor         |
| Black           | Engine Ground             | Black           | Engine Ground             |
| Green/Black*    | Anti-reverse Spring       |                 |                           |

\* (1972 models only).

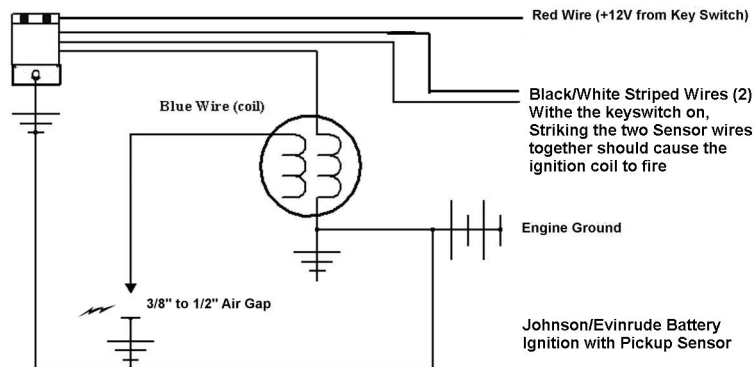

### NO SPARK ON ANY CYLINDER:

1. Connect a spark gap tester to the high tension lead coming from the ignition coil and set it to approximately 1/2". When you crank the engine over, if it sparks while the spark gap tester is connected to the coil and does not spark through the spark plug wires – there is a problem in the distributor cap, rotor button or spark plug wires.
2. Check the DC voltage present on the Purple (or Red) wire at cranking. It MUST be at least 9.5 volts. If not, there is a problem in the harness, key switch, starter or battery.
3. Check the Anti-reverse spring around the crankshaft. Make sure it is not shorting out the sensor pickup.
4. Check DVA voltage on the Blue (or Green) wire going to the coil while connected, it should be approximately 200 volts at cranking.
5. Disconnect the sensor wires. Turn the ignition switch on and strike the sensor wires together. The unit should spark each time. If it does, this usually means the CD module is good. Check the sensor and sensor air gap.
6. Make sure the triggering ring is the correct one for the type ignition being used. Phase II ignitions require the silver rotor for 1967 models and the Phase II Rotor with wide gaps between the lobes for 1968-1971 engines.



Phase One Rotor



Phase Two Rotor



133-5107 1967 Belt Driven Rotor (must be silver color)

## Johnson/Evinrude Troubleshooting

- Reset the Phase II Rotor air gap to 0.020 in. If this allows the pack to spark, leave the gap at that setting.

### SPARKS OUT OF TIME:

- 1967 Models- Check the rotor inside the distributor cap. It should be the Silver colored one – NOT the Brass colored one.
- Connect a spark gap tester to the high-tension leads coming from the distributor cap and set the gap to approximately 7/16". Align the rotor with #1 spark plug wire. Turn the ignition switch on and strike the sensor's wires together. Only the #1 spark plug wire should spark. If any of the other spark plug wires have spark, there is a problem in the distributor cap. Repeat the test for the other cylinders.

### MID-RANGE MISS:

- Check the battery voltage at approximately 3500-RPM, MAXIMUM reading allowable is 15.5 volts, measured at the power pack. Over 15.5 volts may damage the ignition. Check for loose connections or a bad battery.
- 1968-1972 Models – Check the Rotor. It should be the Phase II. The Phase I can cause this problem.
- Connect a spark gap tester to the high-tension leads coming from the distributor cap and set the gap to approximately 7/16". Align the rotor with #1 spark plug wire. Turn the ignition switch on and strike the sensor's wires together. Only the #1 spark plug wire should spark. If any of the other spark plug wires have spark, there is a problem in the distributor cap. Repeat the test for the other cylinders.

## Johnson/Evinrude

### Two Cylinder Engines

#### 1971-1977 50-55 HP Models (With Screw Terminal Power Pack)

### NO SPARK ON ANY CYLINDER:

- Disconnect the Black/Yellow stop wire AT THE POWER PACK and retest. If the engine's ignition has spark, the stop circuit has a fault. Check the key switch, harness and shift switch.
- Disconnect the Yellow wires from the rectifier and retest. If the engine now has spark, replace the rectifier.
- Check the cranking RPM. A cranking speed of less than 250-RPM will not allow the system to spark properly. This can be caused by a weak battery, dragging starter, bad battery cables or a mechanical problem inside the engine.
- Inspect and clean all engine and ignition ground connections.
- Check the stator and timer base resistance and DVA output as given below:

| WIRE        | READ TO     | OEM Ohms | CDI Ohms | DVA (Connected) | DVA (Disconnected) |
|-------------|-------------|----------|----------|-----------------|--------------------|
| Brown       | Engine GND  | 400-600  | 650-850  | 150-400 V       | 150-400 V (*)      |
| Black/White | White/Black | 10-20    | 16-20    | 0.6 V +         | 0.6 V + (#)        |
| Black/White | Engine GND  | Open     | Open     | 150-400 V (a)   | N/A                |
| White/Black | Engine GND  | Open     | Open     | 150-400 V (a)   | N/A                |

(\*) This reading can be used to determine if a stator or pack has a problem. For instance, if you have no spark on any cylinder and the stator's DVA reading is low – disconnect the stator wires and recheck the DVA output. If the reading stays low – the stator is bad. If the reading is now within spec – the pack is bad.

(#) This reading can be used to determine if a pack has a problem in the triggering circuit. For instance, if you have no spark on one cylinder and the timer base's DVA reading for that cylinder is low – disconnect the timer base wires and recheck the DVA output. If the reading stays low – the timer base is bad. If the reading is now within spec – the pack is bad.

(a) The trigger signal rides on top of the high voltage on these timer bases. Check stator DVA first. Then if timer base DVA is 0.6 - 2.5 V, the pack is faulty.

- If the timer base output is low, you may try to reset the air gap between the timer base sensor and the triggering magnet. See below for resetting the air gap:
  - Loosen the two mounting screws on the sensor and the nut located in the epoxy on the outside of the heat shield of the timer base.
  - Slide the sensor in toward the crankshaft approximately 0.005" at a time.
  - Coat the face of the sensor with machinists bluing or equivalent.
  - Install the flywheel according to the service manual and crank the engine over.

## **Johnson/Evinrude Troubleshooting**

- e) Remove the flywheel and check to see if the triggering magnet struck the sensor face.
  - f) If the ignition sparked, finger tight the nut on the outside of the heat shield and coat it with RTV.
  - g) If still no spark, slide the sensor in another 0.005" and repeat steps c through f until the sensor strikes the triggering magnet. Then back the sensor off 0.005". A continued problem can indicate a bad sensor.
7. With another person's help, verify the triggering circuit inside the power pack as follows: Disconnect the timer base wires and using a good 1-1/2 volt battery (AA or larger), connect a jumper wire to each timer base terminal. Hold one jumper wire to the negative side of the battery. Have the other person crank the engine over and tap the remaining jumper wire to the positive side of the battery. (Be careful not to touch the engine or stand in water as the triggering circuit is 'riding high' on the high voltage inside the power pack). You should get a spark from the ignition coil with each tap. Reverse the connections to the battery and test again. If you get sparks from both tests, the power pack should be OK.
  8. Check the DVA voltage on each timer base wire to engine ground. You should have a reading of at least 150V or more from the Black/White wire and the White/Black wire to engine ground (while connected to the pack). If the reading is low, disconnect the timer base wires from the pack and recheck the terminals ON THE PACK. If the voltage jumps up to an acceptable reading, the timer base may have a problem in its internal wiring (a thin spot in the insulation on one wire).
  9. Check the triggering and charge coil flywheel magnets for cracked, broken and loose magnets.

### **NO SPARK OR INTERMITTENT SPARK ON ONE CYLINDER:**

1. Check the timer base resistance and DVA output (see NO SPARK ON ANY CYLINDER above).
2. Check the timer base per steps #7 & #8 above.
3. Check the DVA output from the power pack. You should read at least 150V DVA while connected.
4. Visually inspect the ignition coils for burned or discolored areas and cracks in the casing (indicating arcing inside the coil).
5. Swap the ignition coil with one that is sparking correctly.
6. Rare causes include a weak trigger magnet. If possible, try another flywheel.

### **POWER PACK OR TIMER BASE REPEATEDLY BLOWS ON SAME CYLINDER:**

1. Check the timer base wires for shorts to engine ground as a shorted timer base wire can destroy a SCR inside the power pack.
2. In contrast, a shorted SCR inside the power pack can destroy a timer base coil. Check the timer base resistance and DVA output (see NO SPARK ON ANY CYLINDER above).
3. Replace the ignition coil on the cylinder dropping spark.

### **ENGINE WILL NOT SHUT OFF:**

Disconnect the stop wire at the power pack. Connect a jumper wire to the stop wire from the pack and short it to engine ground. If this stops the pack from sparking, the stop circuit has a fault. Check the key switch, harness and shift switch. If this does not stop the pack from sparking, replace the power pack. Repeat test as necessary for additional packs.

### **MISS AT ANY RPM:**

1. Disconnect the Yellow wires from the stator to the rectifier and retest. If the miss clears, replace the rectifier.
2. In the water or on a Dynameters, check the DVA output on the Orange wires from the power pack while connected to the ignition coils. You should have a reading of at least 150V DVA or more, increasing with engine RPM until it reaches 300-400V DVA maximum. A sharp drop in DVA right before the miss becomes apparent on all cylinders will normally be caused by a bad stator. A sharp drop in DVA on less than all cylinders will normally be the power pack or timer base.
3. Connect an inductive tachometer to each cylinder in turn and try to isolate the problem. A high variance in RPM on one cylinder usually indicates a problem in the power pack or ignition coil. Occasionally a timer base will cause this same problem. Check the timer base DVA voltage (see NO SPARK ON ANY CYLINDER above).
4. Perform a high-speed shutdown and read the spark plugs. Check for water. A crack in the block can cause a miss at high speed when the water pressure gets high, but a normal shutdown will mask the problem.
5. Check the triggering and charge coil flywheel magnets for cracked, broken and loose magnets.

## Johnson/Evinrude Troubleshooting

### Three Cylinder Engines

#### 1972-1978 65-75 HP Models (With Screw Terminal Power Packs)

##### NO SPARK ON ANY CYLINDER:

(Note) If the ignition only sparks with the spark plugs out, the timer base is likely weak or the engine is not spinning fast enough. See steps #3 and #7 below.

1. Disconnect the Black/Yellow stop wire AT THE POWER PACK and retest. If the engine's ignition has spark, the stop circuit has a fault. Check the key switch, harness and shift switch.
2. Disconnect the Yellow wires from the rectifier and retest. If the engine now sparks, replace the rectifier.
3. Check the cranking RPM. A cranking speed of less than 250-RPM will not allow the system to spark properly. This can be caused by a weak battery, dragging starter, bad battery cables or a mechanical problem inside the engine.
4. Inspect and clean all engine and ignition ground connections.
5. Check the stator and timer base resistance and DVA output as given below:

| WIRE        | READ TO           | OEM Ohms          | CDI Ohms | DVA (Connected) | DVA<br>(Disconnected) |
|-------------|-------------------|-------------------|----------|-----------------|-----------------------|
| Brown       | Brown/Yellow      | 870-930 (1973)    | 650-850  | 150-400 V       | 150-400 V (*)         |
| Brown       | Brown/Yellow      | 555-705 (1974-78) | 650-850  | 150-400 V       | 150-400 V (*)         |
| Black/White | White/Black (all) | 10-20             | 35-55    | 0.6 V +         | 0.6 V + (#)           |
| Black/White | Engine GND        | Open              | Open     | 150-400 V (a)   | N/A                   |
| White/Black | Engine GND        | Open              | Open     | 150-400 V (a)   | N/A                   |

(\*) This reading can be used to determine if a stator or pack has a problem. For instance, if you have no spark on any cylinder and the stator's DVA reading is low – disconnect the stator wires and recheck the DVA output. If the reading stays low – the stator is bad. If the reading is now within spec – the pack is bad.

(#) This reading can be used to determine if a pack has a problem in the triggering circuit. For instance, if you have no spark on one cylinder and the timer base's DVA reading for that cylinder is low – disconnect the timer base wires and recheck the DVA output. If the reading stays low – the timer base is bad. If the reading is now within spec – the pack is bad.

(a) The trigger signal rides on top of the high voltage on these timer bases. Check stator DVA first. Then if timer base DVA is 0.6 - 2.5 V, the pack is faulty.

6. If the timer base output is low, you may try to reset the air gap between the timer base sensor and the triggering magnet using a Sensor Gap Gauge (553-9702) or use the following procedure outlined below.
  - a) Loosen the two mounting screws on the sensors and the nuts located in the epoxy on the outside of the heat shield of the timer base and slide the sensors in toward the crankshaft until the sensor touches the stop boss located at the base of the sensor mounting area. Tighten the mounting screws.
  - b) Coat the face of the sensor with machinists bluing or equivalent and install the flywheel without the key and rotate the flywheel at least one full turn.
  - c) Remove the flywheel and check to see if the triggering magnet struck the sensor face. If it did, back the sensor out approximately 0.005".
  - d) If the ignition has spark, finger tight the nut on the outside of the heat shield and coat it with RTV.
  - e) If still no spark, replace the timer base.
7. Check the DVA voltage on the Black/White wire to engine ground. You should have a reading of at least 150V or more (while connected to the pack). If the reading is low, disconnect the timer base wires from the pack and recheck the Black/White terminal ON THE PACK. If the voltage jumps up to an acceptable reading, the timer base may have a problem in the internal wiring (A thin spot in the insulation on one wire).
8. Check the center hub triggering magnet in the flywheel. A loose magnet can cause this problem.
9. Check the triggering and charge coil flywheel magnets for cracked, broken and loose magnets.

##### NO SPARK OR INTERMITTENT SPARK ON ONE OR MORE CYLINDERS:

1. Disconnect the Yellow wires from the rectifier and retest. If the engine has good spark, replace the rectifier.
2. Check the timer base resistance and DVA output (see NO SPARK ON ANY CYLINDER above).
3. Swap the timer base wires and see if the no spark problem follows a timer base wire.

## **Johnson/Evinrude Troubleshooting**

- Disconnect the timer base from the pack and check the resistance in the pack as follows:

| Red meter lead       | Black meter lead | Reading      |
|----------------------|------------------|--------------|
| Black/White terminal | Sensor 1         | 100-200 ohms |
| Black/White terminal | Sensor 2         | 100-200 ohms |
| Black/White terminal | Sensor 3         | 100-200 ohms |

All readings should be fairly even. If the sensor reading in the pack for the cylinder not firing shows over a 10% different reading compared to the other sensors, the pack needs replacing.

- Check the DVA output on the Orange wires from the power pack while connected to the ignition coils. You should have a reading of at least 150V or more. If the reading is low on one cylinder, disconnect the Orange wire from the ignition coil for that cylinder and reconnect it to a load resistor. Retest. If the reading is good, the ignition coil is likely bad. A continued low reading indicates a bad power pack.
- Visually inspect the ignition coils for burned or discolored areas and cracks in the casing (indicating arcing inside the coil).
- Swap the ignition coil with one that is sparking correctly.
- Rare causes include a weak trigger magnet. If possible, try another flywheel.

### **POWER PACK OR TIMER BASE REPEATEDLY BLOWS ON SAME CYLINDER:**

- Check the timer base wires for shorts to engine ground as a shorted timer base wire can destroy a SCR inside the power pack.
- In contrast, a shorted SCR inside the power pack can destroy a timer base coil. Check the timer base resistance and DVA output (see NO SPARK ON ANY CYLINDER above).
- Replace the ignition coil on the cylinder dropping spark.

### **ENGINE WILL NOT SHUT OFF:**

Disconnect the stop wire at the power pack. Connect a jumper wire to the stop wire from the pack and short it to engine ground. If this stops the pack from sparking, the stop circuit has a fault. Check the key switch, harness and shift switch. If this does not stop the pack from sparking, replace the power pack. Repeat test as necessary for additional packs.

### **MISS AT ANY RPM:**

- Disconnect the Yellow wires from the stator to the rectifier and retest. If the miss clears, replace the rectifier.
- In the water or on a Dynameters, check the DVA output on the Orange wires from the power pack while connected to the ignition coils. You should have a reading of at least 150V DVA or more, increasing with engine RPM until it reaches 300-400V DVA maximum. A sharp drop in DVA right before the miss becomes apparent on all cylinders will normally be caused by a bad stator. A sharp drop in DVA on less than all cylinders will normally be the power pack or timer base.
- Connect an inductive tachometer to each cylinder in turn and try to isolate the problem. A high variance in RPM on one cylinder usually indicates a problem in the power pack or ignition coil. Occasionally a timer base will cause this same problem. Check the timer base DVA voltage (see NO SPARK ON ANY CYLINDER above).
- Perform a high-speed shutdown and read the spark plugs. Check for water. A crack in the block can cause a miss at high speed when the water pressure gets high, but a normal shutdown will mask the problem.
- Check the triggering and charge coil flywheel magnets for cracked, broken and loose magnets.

## **Four Cylinder Engines**

### **1973-1977 85-140 HP Models (With Screw Terminal Power Packs)**

#### **NO SPARK ON ANY CYLINDER:**

(Note) If the engine has spark with the spark plugs out but not with them installed, the timer base is either weak or the engine is not spinning fast enough. See steps #3 and #7 below.

- Disconnect the Black/Yellow stop wire AT THE POWER PACK and retest. If the engines' ignition now has spark, the stop circuit has a fault. Check the key switch, harness and shift switch.
- Disconnect the Yellow wires from the rectifier and retest. If the engine has spark, replace the rectifier.
- Check the cranking RPM. A cranking speed of less than 250-RPM will not allow the system to spark properly. This can be caused by a weak battery, dragging starter, bad battery cables or a mechanical problem inside the engine.



## Johnson/Evinrude Troubleshooting

4. Inspect and clean all engine and ignition ground connections.
5. Check the stator and timer base resistance and DVA output as given below:

| WIRE              | READ TO          | OEM Ohms          | CDI Ohms | DVA (Connected) | DVA (Disconnected) |
|-------------------|------------------|-------------------|----------|-----------------|--------------------|
| Brown             | Brown/Yellow     | 835-985 (1973)    | 650-850  | 150-400 V       | 150-400 V (*)      |
| Brown             | Brown/Yellow     | 555-705 (1974-77) | 650-850  | 150-400 V       | 150-400 V (*)      |
| Black/White (#1)  | White/Black (#3) | 10-20             | 35-55    | 0.6 V +         | 0.6 V + (#)        |
| Black/White (#2)  | White/Black (#4) | 10-20             | 35-55    | 0.6 V +         | 0.6 V + (#)        |
| Black/White (all) | Engine GND       | Open              | Open     | 150-400 V (a)   | N/A                |
| White/Black (all) | Engine GND       | Open              | Open     | 150-400 V (a)   | N/A                |

(\*) This reading can be used to determine if a stator or pack has a problem. For instance, if you have no spark on any cylinder and the stator's DVA reading is low – disconnect the stator wires and recheck the DVA output. If the reading stays low – the stator is bad. If the reading is now within spec – the pack is bad.

(#) This reading can be used to determine if a pack has a problem in the triggering circuit. For instance, if you have no spark on one cylinder and the timer base's DVA reading for that cylinder is low – disconnect the timer base wires and recheck the DVA output. If the reading stays low – the timer base is bad. If the reading is now within spec – the pack is bad.

(a) The trigger signal rides on top of the high voltage on these timer bases. Check stator DVA first. Then if timer base DVA is 0.6 - 2.5 V, the pack is faulty.

6. If the timer base output is low, you may try to reset the air gap between the timer base sensor and the triggering magnet using a Sensor Gap Gauge (553-9702) or use the following procedure:
  - a) Loosen the two mounting screws on the sensors and the nuts located in the epoxy on the outside of the heat shield of the timer base.
  - b) Slide the sensors in toward the crankshaft until the sensor touches the stop boss located at the base of the sensor mounting area. Tighten the mounting screws.
  - c) Coat the face of the sensors with machinists bluing or equivalent.
  - d) Install the flywheel without the key and rotate the flywheel at least one full turn.
  - e) Remove the flywheel and check to see if the triggering magnet struck the face of the sensors. If it did, back the sensor out approximately 0.005" and repeat steps c, d and e.
  - f) If the ignition sparked, finger tight the nuts on the outside of the heat shield and coat them with RTV.
  - g) If still no spark, replace the sensor.
7. Check the DVA voltage on each Black/White wire to engine ground. You should have a reading of at least 150V or more (while connected to the pack). If the reading is low, disconnect the timer base wires from the pack and recheck the Black/White terminals ON THE PACK. If the voltage jumps up to an acceptable reading, the timer base may have a problem in the internal wiring (possibly a thin spot in the insulation on one wire).
8. Check the triggering and charge coil flywheel magnets for cracked, broken and loose magnets.

### NO SPARK OR INTERMITTENT SPARK ON ONE BANK:

1. Swap the timer base wire sets (swap the #1 & #3 pair with the #2 & #4 pair) and see if the no spark problem follows a timer base wire.
2. Check the timer base resistance and DVA output (see NO SPARK ON ANY CYLINDER above). If the DVA output is low, you may try to reset the air gap between the timer base sensor and the triggering magnet using a sensor gap gauge or use the procedure outlined in Step #6 (see NO SPARK ON ANY CYLINDER above).
3. Check the DVA output on the Orange wires from the power pack while connected to the ignition coils. You should have a reading of at least 150V or more. If the reading is low on one cylinder, disconnect the Orange wire from the ignition coil for that cylinder and connect a load resistor to that terminal. Retest. If the reading is now good, the ignition coil is likely bad. A continued low reading indicates a bad power pack.

### NO SPARK OR INTERMITTENT SPARK ON ONE OR MORE CYLINDERS:

1. Disconnect the Yellow wires from the rectifier and retest. If the engine has good spark, replace the rectifier.
2. Check the timer base resistance and DVA output (see NO SPARK ON ANY CYLINDER above).
3. Swap the timer base wire sets (swap the #1 & #3 pair with the #2 & #4 pair) and see if the no spark problem follows a timer base wire.
4. Check the DVA output on the Orange wires from the power pack while connected to the ignition coils. You should have a reading of at least 150V or more. If the reading is low on one cylinder, disconnect the Orange

## **Johnson/Evinrude Troubleshooting**

wire from the ignition coil for that cylinder and reconnect it to a load resistor. Retest. If the reading is good, the ignition coil is likely bad. A continued low reading indicates a bad power pack.

5. Visually inspect the ignition coils for burned or discolored areas and cracks in the casing (indicating arcing inside the coil).
6. Swap the ignition coil with one that is sparking correctly.
7. Rare causes include a weak trigger magnet. If possible, try another flywheel.

### **POWER PACK OR TIMER BASE REPEATEDLY BLOWS ON SAME CYLINDER:**

1. Check the timer base wires for shorts to engine ground as a shorted timer base wire can destroy a SCR inside the power pack.
2. In contrast, a shorted SCR inside the power pack can destroy a timer base coil. Check the timer base resistance and DVA output (see NO SPARK ON ANY CYLINDER above).
3. Replace the ignition coil on the cylinder dropping spark.

### **ENGINE WILL NOT SHUT OFF:**

Disconnect the stop wire at the power pack. Connect a jumper wire to the stop wire from the pack and short it to engine ground. If this stops the pack from sparking, the stop circuit has a fault. Check the key switch, harness and shift switch. If this does not stop the pack from sparking, replace the power pack. Repeat test as necessary for additional packs.

### **MISS AT ANY RPM:**

1. Disconnect the Yellow wires from the stator to the rectifier and retest. If the miss clears, replace the rectifier.
2. In the water or on a Dynameters, check the DVA output on the Orange wires from the power pack while connected to the ignition coils. You should have a reading of at least 150V DVA or more, increasing with engine RPM until it reaches 300-400V DVA maximum. A sharp drop in DVA right before the miss becomes apparent on all cylinders will normally be caused by a bad stator. A sharp drop in DVA on less than all cylinders will normally be the power pack or timer base.
3. Connect an inductive tachometer to each cylinder in turn and try to isolate the problem. A high variance in RPM on one cylinder usually indicates a problem in the power pack or ignition coil. Occasionally a timer base will cause this same problem. Check the timer base DVA voltage (see NO SPARK ON ANY CYLINDER above).
4. Perform a high-speed shutdown and read the spark plugs. Check for water. A crack in the block can cause a miss at high speed when the water pressure gets high, but a normal shutdown will mask the problem.
5. Check the triggering and charge coil flywheel magnets for cracked, broken and loose magnets.

## **Six Cylinder Engines**

### **1976-1978 150-235 HP Models (With Screw Terminal Power Packs)**

#### **NO SPARK ON ANY CYLINDER:**

(Note) If the engine has spark with the spark plugs out but not with them installed, the timer base is likely weak or the engine is not spinning fast enough. See steps #3 and #6 below.

1. Disconnect the Black/Yellow stop wires AT THE POWER PACKS and retest. If the engine's ignition has spark, the stop circuit has a fault. Check the key switch, harness and shift switch.
2. Disconnect the Yellow wires from the rectifier and retest. If the engine has spark, replace the rectifier.
3. Check the cranking RPM. A cranking speed of less than 250-RPM will not allow the system to spark properly. This can be caused by a weak battery, dragging starter, bad battery cables or a mechanical problem inside the engine.
4. Inspect and clean all engine and ignition ground connections.

## Johnson/Evinrude Troubleshooting

5. Check the stator and timer base resistance and DVA output as given below:

| WIRE   | READ TO          | OEM Ohms       | CDI Ohms | DVA (Connected) | DVA (Disconnected) |
|--------|------------------|----------------|----------|-----------------|--------------------|
| Brown  | Brown/Yellow (b) | 220-330        | 650-850  | 150-400 V       | 50-400 V (*)       |
| White  | Blue (c)         | 11-17(1976-77) | 35-55    | 0.6 V +         | 0.6 V + (#)        |
| White  | Blue (c)         | 13-23(1978)    | 35-55    | 0.6 V +         | 0.6 V + (#)        |
| White  | Purple (c)       | 11-17(1976-77) | 35-55    | 0.6 V +         | 0.6 V + (#)        |
| White  | Purple (c)       | 13-23(1978)    | 35-55    | 0.6 V +         | 0.6 V + (#)        |
| White  | Green (c)        | 11-17(1976-77) | 35-55    | 0.6 V +         | 0.6 V + (#)        |
| White  | Green (c)        | 13-23(1978)    | 35-55    | 0.6 V +         | 0.6 V + (#)        |
| White  | Engine GND       | Open           | Open     | 150-400 V (a)   | N/A                |
| Blue   | Engine GND       | Open           | Open     | 150-400 V (a)   | N/A                |
| Purple | Engine GND       | Open           | Open     | 150-400 V (a)   | N/A                |
| Green  | Engine GND       | Open           | Open     | 150-400 V (a)   | N/A                |

(\*) This reading can be used to determine if a stator or pack has a problem. For instance, if you have no spark on any cylinder and the stator's DVA reading is low – disconnect the stator wires and recheck the DVA output. If the reading stays low – the stator is bad. If the reading is now within spec – the pack is bad.

(#) This reading can be used to determine if a pack has a problem in the triggering circuit. For instance, if you have no spark on one cylinder and the timer base's DVA reading for that cylinder is low – disconnect the timer base wires and recheck the DVA output. If the reading stays low – the timer base is bad. If the reading is now within spec – the pack is bad.

(a) The trigger signal rides on top of the high voltage on these timer bases. Check stator DVA first. Then if timer base DVA is 0.6 - 2.5 V, the pack is faulty.

(b) Check both pairs of stator charge coils.

(c) Check both sides of the timer base.

6. Check the DVA voltage on the White wire to engine ground. You should have a reading of at least 150V or more (while connected to the pack). If the reading is low, disconnect the timer base wires from the pack and recheck the White terminal ON THE PACK. If the voltage jumps up to an acceptable reading, the timer base may have a problem in the internal wiring (possibly a thin spot in the insulation on one wire).
7. Check the triggering and charge coil flywheel magnets for cracked, broken and loose magnets.

### NO SPARK OR INTERMITTENT SPARK ON ONE BANK:

1. Disconnect the stop wires from both power packs and retest. If the spark comes back, swap the power packs from side to side and reconnect the stop circuit. If the no spark problem remains on the same bank, the stop circuit is bad. Check the key switch, harness and shift switch. If the problem moves, replace the power pack that was firing correctly due to a bad blocking diode in the pack.
2. Swap the stator wire pairs from one side of the engine to the other side and see if the problem moves. If it does, the stator is bad.
3. Check the stator and timer base resistance and DVA output on BOTH banks (see NO SPARK ON ANY CYLINDER above).

### NO SPARK OR INTERMITTENT SPARK ON ONE OR MORE CYLINDERS:

1. Disconnect the Yellow wires from the rectifier and retest. If the engine has good spark, replace the rectifier.
2. Check the timer base resistance and DVA output on BOTH banks (see NO SPARK ON ANY CYLINDER above).
3. Check the DVA output from the timer base. A reading of at least 0.6V or more from the White wire to the Blue, Green and Purple wires (while connected to the pack) is needed to spark the pack.
4. Disconnect the timer base from the pack and check the resistance in the pack as follows:

| Red meter lead       | Black meter lead | Reading      |
|----------------------|------------------|--------------|
| Black/White terminal | Sensor 1         | 100-200 ohms |
| Black/White terminal | Sensor 2         | 100-200 ohms |
| Black/White terminal | Sensor 3         | 100-200 ohms |

All readings should be fairly even. If the sensor reading in the pack for the cylinder not firing shows over a 10% different reading compared to the other sensors, the pack needs replacing.
5. Check the DVA output on the Orange wires from the power pack while connected to the ignition coils. You should have a reading of at least 150V or more. If the reading is low on one cylinder, disconnect the Orange wire from the ignition coil for that cylinder and reconnect it to a load resistor. Retest. If the reading is now good, the ignition coil is likely bad. A continued low reading indicates a bad power pack.

## **Johnson/Evinrude Troubleshooting**

6. Visually inspect the ignition coils for burned or discolored areas and cracks in the casing (indicating arcing inside the coil).
7. Swap the ignition coil with one that is sparking correctly.
8. Rare causes include a weak trigger magnet. If possible, try another flywheel.

### **POWER PACK OR TIMER BASE REPEATEDLY BLOWS ON SAME CYLINDER:**

1. Check the timer base wires for shorts to engine ground as a shorted timer base wire can destroy a SCR inside the power pack.
2. In contrast, a shorted SCR inside the power pack can destroy a timer base coil. Check the timer base resistance and DVA output (see NO SPARK ON ANY CYLINDER above).
3. Replace the ignition coil on the cylinder dropping spark.

### **ENGINE WILL NOT SHUT OFF:**

Disconnect the stop wire at the power pack. Connect a jumper wire to the stop wire from the pack and short it to engine ground. If this stops the pack from sparking, the stop circuit has a fault. Check the key switch, harness and shift switch. If this does not stop the pack from sparking, replace the power pack. Repeat test as necessary for additional packs.

### **MISS AT ANY RPM:**

1. Disconnect the Yellow wires from the stator to the rectifier and retest. If the miss clears, replace the rectifier.
2. In the water or on a Dynameters, check the DVA output on the Orange wires from the power pack while connected to the ignition coils. You should have a reading of at least 150V DVA or more, increasing with engine RPM until it reaches 300-400V DVA maximum. A sharp drop in DVA right before the miss becomes apparent on all cylinders will normally be caused by a bad stator. A sharp drop in DVA on less than all cylinders will normally be the power pack or timer base.
3. Connect an inductive tachometer to each cylinder in turn and try to isolate the problem. A high variance in RPM on one cylinder usually indicates a problem in the power pack or ignition coil. Occasionally a timer base will cause this same problem. Check the timer base DVA voltage (see NO SPARK ON ANY CYLINDER above).
4. Perform a high-speed shutdown and read the spark plugs. Check for water. A crack in the block can cause a miss at high speed when the water pressure gets high, but a normal shutdown will mask the problem.
5. Check the triggering and charge coil flywheel magnets for cracked, broken and loose magnets.

**Johnson/Evinrude Troubleshooting**

**JOHNSON/EVINRUDE Flywheel Trigger Magnet Location**

This drawing is to be used to determine if the flywheel sensor magnet has moved from it's original location only.

**2 Cylinder  
Loop Charged**

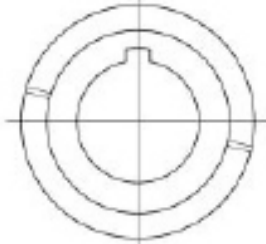

**1979-1987 3 Cylinder  
CROSS FLOW**

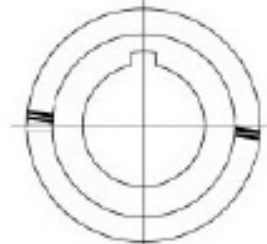

**1988-2001 3 Cyl  
Loop Charged**

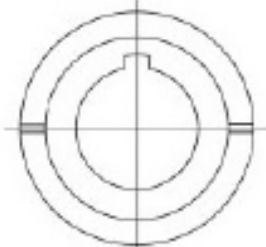

**1987 and Older V4  
90 Degree Cross Flow**

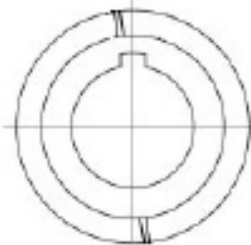

**1988 and Newer V4  
90 Degree Cross Flow**

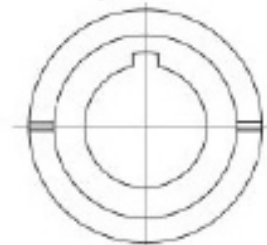

**1988 & Newer V4  
90 Degree Cross Flow**

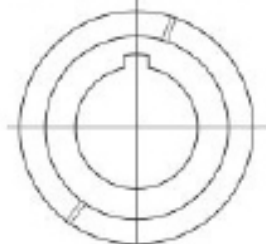

**1976-1988  
V6 Cross Flow**

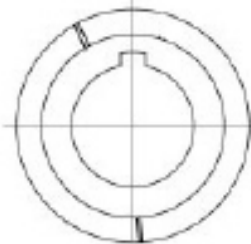

**1986-1987 V4 & V6  
90 Degree Loop Charged**

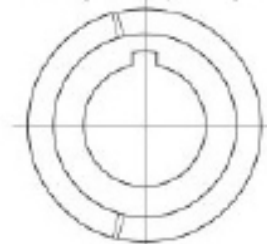

**1988-1992  
150-175 Cross Flow**

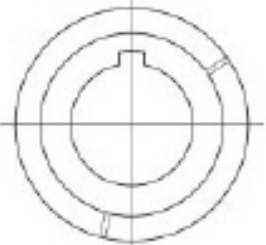

**1988-2001  
185-250 V6 Loop Charged**

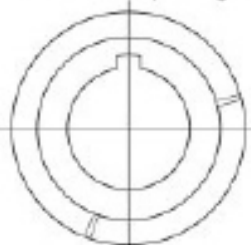

**1988-1989 V4 & V6  
90 Degree Loop Charged**

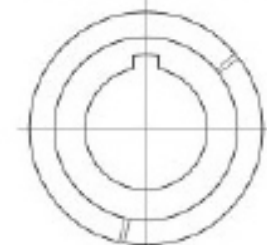



# Johnson/Evinrude Troubleshooting

## Johnson/Evinrude Alternator Driven CD Ignitions 1977-2006 Two Stroke Carbureted Engines

### Two Cylinder Two Stroke Engines 1978-2007 4-60 HP Models

**Service Note: Please use the Factory recommended spark plug (currently Champion QL77JC4) gapped at 0.030”.**

**NO SPARK ON ANY CYLINDER:**

1. Disconnect the Black/Yellow stop wire AT THE POWER PACK and retest. If the engine's ignition has spark, the stop circuit has a fault. Check the key switch, harness and shift switch.
2. Disconnect the Yellow wires from the rectifier and retest. If the engine has spark, replace the rectifier.
3. Check the cranking RPM. A cranking speed of less than 250-RPM will not allow the system to spark properly. This can be caused by a weak battery, dragging starter, bad battery cables or a mechanical problem inside the engine.
4. Inspect and clean all engine and ignition ground connections.
5. Check the stator and timer base resistance and DVA output as given below:

**Engines Without SLOW Function (Two Wire Trigger)**

| WIRE         | READ TO      | OEM Ohms            | CDI Ohms | DVA (Connected) | DVA (Disconnected) |
|--------------|--------------|---------------------|----------|-----------------|--------------------|
| Brown        | Brown/Yellow | 500-650(1978-84)    | 500-650  | 150-400 V       | 150-400 V (*)      |
| Brown        | Brown/Yellow | 550-600(1985-1988)  | 500-650  | 150-400 V       | 150-400 V (*)      |
| Brown        | Brown/Yellow | 535-685(1989-1992)  | 500-650  | 150-400 V       | 150-400 V (*)      |
| Brown        | Brown/Yellow | 800-1000(1993-2007) | 500-650  | 150-400 V       | 150-400 V (*)      |
| Brown        | Engine GND   | Open                | Open     | 150-400 V       | < 2 V (c)          |
| Brown/Yellow | Engine GND   | Open                | Open     | 150-400 V       | < 2 V (c)          |
| Black/White  | White/Black  | 30-50               | 45-55    | 0.6V or more    | 0.6V or more       |
| Black/White  | Engine GND   | Open                | Open     | 0.6V or more    | < 2 V (c)          |
| White/Black  | Engine GND   | Open                | Open     | 0.6V or more    | < 2 V (c)          |

**1993-2001 40-55 HP 2 Cylinder Engines With SLOW Function (Three Wire Trigger)**

| WIRE   | READ TO      | OEM Ohms | CDI Ohms | DVA (Connected) | DVA (Disconnected) |
|--------|--------------|----------|----------|-----------------|--------------------|
| Brown  | Brown/Yellow | 750-950  | 650-850  | 150-400 V       | 150-400 V (*)      |
| Orange | Orange/Black | 360-440  | 45-55    | 11-22 V         | 45-120 V (*)       |
| White  | Blue         | 22-32    | 25-30    | 100-400 V (a)   | 0.6 V + (#)        |
| White  | Green        | 22-32    | 25-30    | 100-400 V (a)   | 0.6 V + (#)        |
| White  | Engine GND   | Open     | Open     | SHORTED         | N/A                |
| Blue   | Engine GND   | Open     | Open     | 100-400 V (a)   | N/A                |
| Green  | Engine GND   | Open     | Open     | 100-400 V (a)   | N/A                |

(\*) This reading can be used to determine if a stator or pack has a problem. For instance, if you have no spark on any cylinder and the stator's DVA reading is out of spec – disconnect the stator wires and recheck the DVA output. If the reading is still out of spec – the stator is bad. If the reading is now within spec – the pack is bad.

(#) This reading can be used to determine if a pack has a problem in the triggering circuit. For instance, if you have no spark on one cylinder and the timer base's DVA reading for that cylinder is low – disconnect the timer base wires and recheck the DVA output. If the reading stays low – the timer base is bad. If the reading is now within spec – the pack is bad.

(a) Check stator DVA first. Then if timer base DVA is 0.6 - 2.5 V, the pack is faulty. If below 0.6 V, the timer base is faulty if cranking RPM is over 250.

(b) The trigger signal rides on top of the high voltage on these timer bases. Check stator DVA first. Then, if timer base DVA is 0.6 - 2.5 V, the pack is faulty.

(c) Some meters will pickup static/stray electricity up to 2 volts.

## **Johnson/Evinrude Troubleshooting**

6. 1988 and newer models: Check the power pack resistance given below:

| WIRE                 | (CYL) | READ TO               | RESISTANCE      |
|----------------------|-------|-----------------------|-----------------|
| Orange/Blue          | (#1)  | Blue                  | 110 (a)         |
| Orange/Green         | (#2)  | Green                 | 110 (a)         |
| White                |       | Black (Engine Ground) | Shorted         |
| Brown & Brown/Yellow |       | Black (Engine Ground) | Open or M range |

- (a) Use a comparison reading as different brands of meters will give different readings. The typical range is 90 to 150 ohms for the Orange wires. You should have approximately the same ohm reading on all six tests with the Orange wires. If one of the SCR's inside the power pack is shorted or open, the readings will be quite a bit different.

7. Check the DVA output on the Orange wires from the power pack while connected to the ignition coils. You should have a reading of at least 150V or more. If the readings are low, disconnect the Orange wires from the ignition coils and reconnect them to a load resistor. Retest. If the reading is now good, the ignition coil is likely bad. A continued low reading indicates a bad power pack.
8. Check the triggering and charge coil flywheel magnets for cracked, broken and loose magnets.

### **NO SPARK ON ONE CYLINDER:**

1. Check the timer base resistance and DVA output (see NO SPARK ON ANY CYLINDER above).
2. Swap the timer base wires and see if the problem follows a timer base wire.
3. Check the DVA output on the Orange wires from the power pack while connected to the ignition coils. You should have a reading of at least 150V or more while connected. If the reading is low on one cylinder, disconnect the Orange wire from the ignition coil for that cylinder and reconnect it to a load resistor. Retest. If the reading is good, the ignition coil is likely bad. A continued low reading indicates a bad power pack.
4. Visually inspect the ignition coils for burned or discolored areas and cracks in the casing (indicating arcing inside the coil).
5. Swap the ignition coil with one that is sparking correctly.
6. Rare causes include a weak trigger magnet. If possible, try another flywheel.

### **POWER PACK OR TIMER BASE REPEATEDLY BLOWS ON SAME CYLINDER:**

1. Check the timer base wires for shorts to engine ground as a shorted timer base wire can destroy a SCR inside the power pack.
2. In contrast, a shorted SCR inside the power pack can destroy a timer base coil. Check the timer base resistance and DVA output (see NO SPARK ON ANY CYLINDER above).
3. Replace the ignition coil on the cylinder dropping spark.

### **ENGINE WILL NOT SHUT OFF:**

Disconnect the stop wire at the power pack. Connect a jumper wire to the stop wire from the pack and short it to engine ground. If this stops the pack from sparking, the stop circuit has a fault. Check the key switch, harness and shift switch. If this does not stop the pack from sparking, replace the power pack. Repeat test as necessary for additional packs.

### **WILL NOT ACCELERATE BEYOND 3000 RPM (Runs smooth below that RPM):**

1. Disconnect the Yellow wires from the rectifier and retest. If the engine runs normally, replace the rectifier.
2. In the water or on a Dynamometer, check the DVA output on the Orange wires from the power pack while connected to the ignition coils. You should have a reading of at least 150V or more, increasing with engine RPM until it reaches 300-400 volts. A sharp drop in voltage right before the miss becomes apparent will normally be caused by a bad stator. A drop on only one Orange wire will normally be the power pack.
3. Check the stator resistance. If it reads approximately 900 ohms, replace it with the 500 ohm design.

## **Johnson/Evinrude Troubleshooting**

### **MISS AT ANY RPM:**

1. Disconnect the Yellow wires from the stator to the rectifier and retest. If the miss clears, replace the rectifier.
2. In the water or on a Dynameters, check the DVA output on the Orange wires from the power pack while connected to the ignition coils. You should have a reading of at least 150V DVA or more, increasing with engine RPM until it reaches 300-400V DVA maximum. A sharp drop in DVA right before the miss becomes apparent on all cylinders will normally be caused by a bad stator. A sharp drop in DVA on less than all cylinders will normally be the power pack or timer base.
3. Connect an inductive tachometer to each cylinder in turn and try to isolate the problem. A high variance in RPM on one cylinder usually indicates a problem in the power pack or ignition coil. Occasionally a timer base will cause this same problem. Check the timer base DVA voltage (see NO SPARK ON ANY CYLINDER above).
4. Perform a high-speed shutdown and read the spark plugs. Check for water. A crack in the block can cause a miss at high speed when the water pressure gets high, but a normal shutdown will mask the problem.
5. Check the triggering and charge coil flywheel magnets for cracked, broken and loose magnets.

### **Models with S.L.O.W.**

### **ENGINE WILL NOT ACCELERATE BEYOND 2500 RPM:**

1. Use a temperature probe and verify that the engine is not overheating.
2. Disconnect the Tan temperature wire from the pack and retest. If the engine now performs properly, check the temperature switch, harness and vacuum sensor.
3. Make sure the Tan temperature switch wire is not located next to a spark plug wire (RF interference can activate the SLOW function).
4. Verify the correct spark plugs are installed (Factory Recommended Champion QL78YC)
5. If the engines still acts up, replace the power pack.

### **SLOW FUNCTION WILL NOT ACTIVATE:**

1. Disconnect the tan temperature wire and short it to engine ground. If the SLOW circuit now operates, replace the temperature sensor.
2. Check the power coil output. You should have at least 10V from the Orange to the Orange/Black wire while they are connected to the power pack. If you have the correct voltage on the power coil, the power pack is likely defective.
3. Check the terminal on the Tan wire for broken wire or corrosion.

**SERVICE NOTE:** If the engine has a miss over 4000 RPM, try using a set of QL78C spark plugs instead of the QL78YC spark plugs.

## Johnson/Evinrude Troubleshooting

### Three Cylinder Two Stroke Engines

#### 1979-1988 60-75 HP Models

Service Note: Please use the Factory recommended spark plug (currently Champion QL77JC4) gapped at 0.030".

#### NO SPARK ON ANY CYLINDER:

1. Disconnect the Black/Yellow stop wire AT THE POWER PACK and retest. If the engine's ignition has spark, the stop circuit has a fault. Check the key switch, harness and shift switch.
2. Disconnect the Yellow wires from the rectifier and retest. If the ignition now has spark, replace the rectifier.
3. Check the cranking RPM. A cranking speed of less than 250-RPM will not allow the system to spark properly. This can be caused by a weak battery, dragging starter, bad battery cables or a mechanical problem inside the engine.
4. Inspect and clean all engine and ignition ground connections.
5. Check the stator and timer base resistance and DVA output as given below:

| WIRE  | READ TO      | OEM Ohms         | CDI Ohms | DVA (Connected) | DVA (Disconnected) |
|-------|--------------|------------------|----------|-----------------|--------------------|
| Brown | Brown/Yellow | 360-440 (9 amp)  | 530-630  | 150-400 V (*)   | 150-400 V (*)      |
| Brown | Brown/Yellow | 750-950 (12 amp) | 530-630  | 150-400 V (*)   | 150-400 V (*)      |
| White | Blue         | 9-21             |          | 0.6 V +         | 0.6 V + (#)        |
| White | Purple       | 9-21             |          | 0.6 V +         | 0.6 V + (#)        |
| White | Green        | 9-21             |          | 0.6 V +         | 0.6 V + (#)        |

(\*) This reading can be used to determine if a stator or pack has a problem. For instance, if you have no spark on any cylinder and the stator's DVA reading is out of spec – disconnect the stator wires and recheck the DVA output. If the reading is still out of spec – the stator is bad. If the reading is now within spec – the pack is likely defective.

(#) This reading can be used to determine if a pack has a problem in the triggering circuit. For instance, if you have no spark on one cylinder and the timer base's DVA reading for that cylinder is low – disconnect the timer base wires and recheck the DVA output. If the reading stays low – the timer base is bad. If the reading is now within spec – the pack is bad.

(a) Check stator DVA first. Then if timer base DVA is 0.6 - 2.5 V, the pack is faulty. If below 0.6 V or 2.6 - 99 V, the timer base is faulty.

6. Check the triggering and charge coil flywheel magnets for cracked, broken and loose magnets.

#### NO SPARK OR INTERMITTENT SPARK ON ONE OR MORE CYLINDERS:

1. Check the timer base resistance and DVA output (see NO SPARK ON ANY CYLINDER above).
2. Check the DVA output on the Orange wires from the power pack while connected to the ignition coils. You should have a reading of at least 150V or more. If the reading is low on one cylinder, disconnect the Orange wire from the ignition coil for that cylinder and reconnect it to a pack load resistor and retest. If the reading is now good, the ignition coil is likely bad. A continued low reading indicates a bad power pack if the timer base checks good.
3. Visually inspect the ignition coils for burned or discolored areas and cracks in the casing (indicating arcing inside the coil).
4. Swap the ignition coil with one that is sparking correctly.
5. Rare causes include a weak trigger magnet. If possible, try another flywheel.

#### POWER PACK OR TIMER BASE REPEATEDLY BLOWS ON SAME CYLINDER:

1. Check the timer base wires for shorts to engine ground as a shorted timer base wire can destroy a SCR inside the power pack.
2. In contrast, a shorted SCR inside the power pack can destroy a timer base coil. Check the timer base resistance and DVA output (see NO SPARK ON ANY CYLINDER above).
3. Replace the ignition coil on the cylinder dropping spark.

#### ENGINE WILL NOT SHUT OFF:

Disconnect the stop wire at the power pack. Connect a jumper wire to the stop wire from the pack and short it to engine ground. If this stops the pack from sparking, the stop circuit has a fault. Check the key switch, harness and shift switch. If the pack is still sparking, replace the power pack.

## **Johnson/Evinrude Troubleshooting**

### **MISS AT ANY RPM:**

1. Disconnect the Yellow wires from the stator to the rectifier and retest. If the miss clears, replace the rectifier.
2. In the water or on a Dynameters, check the DVA output on the Orange wires from the power pack while connected to the ignition coils. You should have a reading of at least 150V DVA or more, increasing with engine RPM until it reaches 300-400V DVA maximum. A sharp drop in DVA right before the miss becomes apparent on all cylinders will normally be caused by a bad stator. A sharp drop in DVA on less than all cylinders will normally be the power pack or timer base.
3. Connect an inductive tachometer to each cylinder in turn and try to isolate the problem. A high variance in RPM on one cylinder usually indicates a problem in the power pack or ignition coil. Occasionally a timer base will cause this same problem. Check the timer base DVA voltage (see NO SPARK ON ANY CYLINDER above).
4. Perform a high-speed shutdown and read the spark plugs. Check for water. A crack in the block can cause a miss at high speed when the water pressure gets high, but a normal shutdown will mask the problem.
5. Check the triggering and charge coil flywheel magnets for cracked, broken and loose magnets.

### **Three Cylinder Two Stroke Engines (With SLOW Function) 1988-1992 60-75 HP Models**

**Service Note:** Please use the Factory recommended spark plug (currently Champion QL77JC4) gapped at 0.030”.

### **NO SPARK ON ANY CYLINDER:**

1. Disconnect the Black/Yellow stop wire AT THE POWER PACK and retest. If the engine’s ignition has spark, the stop circuit has a fault. Check the key switch, harness and shift switch.
2. Disconnect the Yellow wires from the rectifier and retest. If the ignition now has spark, replace the rectifier.
3. Check the cranking RPM. A cranking speed of less than 250-RPM will not allow the system to spark properly. This can be caused by a weak battery, dragging starter, bad battery cables or a mechanical problem inside the engine.
4. Inspect and clean all engine and ignition ground connections.
5. Check the stator and timer base resistance and DVA output as given below:

| WIRE   | READ TO      | OEM Ohms         | CDI Ohms | DVA (Connected) | DVA (Disconnected) |
|--------|--------------|------------------|----------|-----------------|--------------------|
| Brown  | Brown/Yellow | 360-440 (9 amp)  | 530-630  | 150-400 V (*)   | 150-400 V (*)      |
| Brown  | Brown/Yellow | 750-950 (12 amp) | 650-850  | 150-400 V (*)   | 150-400 V (*)      |
| Orange | Orange/Black | 360-440          | 45-55    | 11-22 V         | 45-120 V (*)       |
| White  | Purple       | 9-21             | 9-21     | 0.6 V +         | 0.6 V + (#)        |
| White  | Blue         | 9-21             | 9-21     | 0.6 V +         | 0.6 V + (#)        |
| White  | Green        | 9-21             | 9-21     | 0.6 V +         | 0.6 V + (#)        |

(\*) This reading can be used to determine if a stator or pack has a problem. For instance, if you have no spark on any cylinder and the stator’s DVA reading is out of spec – disconnect the stator wires and recheck the DVA output. If the reading is still out of spec – the stator is bad. If the reading is now within spec – the pack is bad.

(#) This reading can be used to determine if a pack has a problem in the triggering circuit. For instance, if you have no spark on one cylinder and the timer base’s DVA reading for that cylinder is low – disconnect the timer base wires and recheck the DVA output. If the reading stays low – the timer base is bad. If the reading is now within spec – the pack is bad.

6. Check the center hub triggering magnet in the flywheel. A loose magnet can cause this problem.
7. Check the triggering and charge coil flywheel magnets for cracked, broken and loose magnets.

### **NO SPARK OR INTERMITTENT SPARK ON ONE OR MORE CYLINDERS:**

1. Check the timer base resistance and DVA output (see NO SPARK ON ANY CYLINDER above).
2. Check the DVA output on the Orange wires from the power pack while connected to the ignition coils. You should have a reading of at least 150V or more. If the reading is low on one cylinder, disconnect the Orange wire from the ignition coil for that cylinder and reconnect it to a pack load resistor and retest. If the reading is now good, the ignition coil is likely bad. A continued low reading indicates a bad power pack if the timer base checks good.
3. Visually inspect the ignition coils for burned or discolored areas and cracks in the casing (indicating arcing inside the coil).
4. Swap the ignition coil with one that is sparking correctly.



## Johnson/Evinrude Troubleshooting

5. Rare causes include a weak trigger magnet. If possible, try another flywheel.

6. Check the power pack resistance as given below:

| WIRE                 | (CYL) | READ TO               | Resistance                  |
|----------------------|-------|-----------------------|-----------------------------|
| Orange/Blue          | (#1)  | Blue                  | 110 (a) (1988 & newer only) |
| Orange               | (#2)  | Green                 | 110 (a) (1988 & newer only) |
| Orange/Green         | (#3)  | Purple                | 110 (a) (1988 & newer only) |
| White                |       | Black (Engine Ground) | Shorted                     |
| Brown & Brown/Yellow |       | Black (Engine Ground) | Open or M range             |

(a) Use a comparison reading as different brands of meters will give different readings. The typical range is 90 to 150 ohms for the Orange wires. You should have approximately the same ohm reading on all six tests with the Orange wires. If one of the SCR's inside the power pack is shorted or open, the readings will be quite a bit different.

### POWER PACK OR TIMER BASE REPEATEDLY BLOWS ON SAME CYLINDER:

1. Check the timer base wires for shorts to engine ground as a shorted timer base wire can destroy a SCR inside the power pack.
2. In contrast, a shorted SCR inside the power pack can destroy a timer base coil. Check the timer base resistance and DVA output (see NO SPARK ON ANY CYLINDER above).
3. Replace the ignition coil on the cylinder dropping spark.

### ENGINE WILL NOT SHUT OFF:

Disconnect the stop wire at the power pack. Connect a jumper wire to the stop wire from the pack and short it to engine ground. If this stops the pack from sparking, the stop circuit has a fault. Check the key switch, harness and shift switch. If this does not stop the pack from sparking, replace the power pack. Repeat test as necessary for additional packs.

### MISS AT ANY RPM:

1. Disconnect the Yellow wires from the stator to the rectifier and retest. If the miss clears, replace the rectifier.
2. In the water or on a Dynameters, check the DVA output on the Orange wires from the power pack while connected to the ignition coils. You should have a reading of at least 150V DVA or more, increasing with engine RPM until it reaches 300-400V DVA maximum. A sharp drop in DVA right before the miss becomes apparent on all cylinders will normally be caused by a bad stator. A sharp drop in DVA on less than all cylinders will normally be the power pack or timer base.
3. Connect an inductive tachometer to each cylinder in turn and try to isolate the problem. A high variance in RPM on one cylinder usually indicates a problem in the power pack or ignition coil. Occasionally a timer base will cause this same problem. Check the timer base DVA voltage (see NO SPARK ON ANY CYLINDER above).
4. Perform a high-speed shutdown and read the spark plugs. Check for water. A crack in the block can cause a miss at high speed when the water pressure gets high, but a normal shutdown will mask the problem.
5. Check the triggering and charge coil flywheel magnets for cracked, broken and loose magnets.

### ENGINE WILL NOT ACCELERATE BEYOND 2500 RPM (Runs smooth below that RPM):

1. Clean all engine and power pack ground connections.
2. Use a temperature probe and verify that the engine is not overheating.
3. Disconnect the Tan temperature wire from the pack and retest. If the engine now performs properly, the temperature switch is likely bad. Reconnect the Tan wire to the pack if it goes into the harness and disconnect the Tan wire from the temperature switch in the cylinder head. If the engine now performs normally, the temperature switch is defective. If it does not perform correctly, there is likely a problem in the engine harness, VRO (if equipped) or the boat harness.
4. Make sure the Tan temperature switch wire is not located next to a spark plug wire (RF interference can activate the SLOW function).

# Johnson/Evinrude Troubleshooting

## Three Cylinder Engines (1993-2001 40-70 HP Quick-Start Models)

Service Note: Please use the Factory recommended spark plug.  
(Currently Champion QL77JC4/QL78YC) gapped at 0.030".

### NO SPARK ON ANY CYLINDER:

1. Disconnect the Black/Yellow stop wire AT THE POWER PACK and retest. If the engine's ignition has spark, the stop circuit has a fault. Check the key switch, harness and shift switch.
2. Disconnect the Yellow wires from the rectifier and retest. If the ignition now has spark, replace the rectifier.
3. Check the cranking RPM. A cranking speed of less than 250-RPM will not allow the system to spark properly. This can be caused by a weak battery, dragging starter, bad battery cables or a mechanical problem inside the engine.
4. Inspect and clean all engine and ignition ground connections.
5. Check the stator and timer base resistance and DVA output as given below:

| WIRE   | READ TO      | OEM Ohms         | CDI Ohms | DVA (Connected) | DVA (Disconnected) |
|--------|--------------|------------------|----------|-----------------|--------------------|
| Brown  | Brown/Yellow | 750-950 (12 amp) | 650-850  | 150-400 V (*)   | 150-400 V (*)      |
| Orange | Orange/Black | 360-440          | 45-55    | 11-22 V         | 45-120 V (*)       |
| White  | Purple       | (c)              |          | 100-400 V (a)   | 0.6 V + (#)        |
| White  | Blue         | (c)              |          | 100-400 V (a)   | 0.6 V + (#)        |
| White  | Green        | (c)              |          | 100-400 V (a)   | 0.6 V + (#)        |
| White  | Black/White  | 400-500          |          | 6-10 V (b)      | 6-12 V (from pack) |

(\*) This reading can be used to determine if a stator or pack has a problem. For instance, if you have no spark on any cylinder and the stator's DVA reading is out of spec – disconnect the stator wires and recheck the DVA output. If the reading is still out of spec – the stator is bad. If the reading is now within spec – the pack is bad.

(#) This reading can be used to determine if a pack has a problem in the triggering circuit. For instance, if you have no spark on one cylinder and the timer base's DVA reading for that cylinder is low – disconnect the timer base wires and recheck the DVA output. If the reading stays low – the timer base is bad. If the reading is now within spec – the pack is bad.

(a) Check stator DVA first. Then if timer base DVA is 0.6 - 2.5 V, the pack is faulty. If below 0.6 V, the timer base is faulty.

(b) DVA will drop below 1 V when the engine drops out of Quick-Start (engine is over 104 Degrees or 1200 RPM).

(c) This reading will vary according to the meter used. Do a comparison reading and if there is a difference of over 10%, replace the timer base. Typically, use the Red meter lead to the White wire and the Black meter lead to the other wires. The Fluke series meters will typically read 1 MΩ to 2.4 MΩ while the CDI 511-60 meter will read about 5 MΩ.

6. Check the triggering and charge coil flywheel magnets for cracked, broken and loose magnets.

### NO SPARK OR INTERMITTENT SPARK ON ONE OR MORE CYLINDERS:

1. Check the stator and timer base resistance and DVA output (see NO SPARK ON ANY CYLINDER above).
2. Check the DVA output on the Orange wires from the power pack while connected to the ignition coils. You should have a reading of at least 150V or more. If the reading is low on one cylinder, disconnect the Orange wire from the ignition coil for that cylinder and reconnect it to a load resistor. Retest. If the reading is now good, the ignition coil is likely bad. A continued low reading indicates a bad power pack if the timer base checks good.
2. Visually inspect the ignition coils for burned or discolored areas and cracks in the casing (indicating arcing inside the coil).
3. Swap the ignition coil with one that is sparking correctly.
4. Rare causes include a weak trigger magnet. If possible, try another flywheel.
5. Check the power pack resistance given below:

| WIRE                 | (CYL) | READ TO               | Resistance      |
|----------------------|-------|-----------------------|-----------------|
| Orange/Blue          | (#1)  | Blue                  | 110 (a)         |
| Orange               | (#2)  | Purple                | 110 (a)         |
| Orange/Green         | (#3)  | Green                 | 110 (a)         |
| White                |       | Black (Engine Ground) | Shorted         |
| Brown & Brown/Yellow |       | Black (Engine Ground) | Open or M range |

(a) Use a comparison reading as different brands of meters will give different readings. The typical range is 90 to 150 ohms for the Orange wires. You should have approximately the same ohm reading on all six tests with

## **Johnson/Evinrude Troubleshooting**

the Orange wires. If one of the SCR's inside the power pack is shorted or open, the readings will be quite a bit different.

### **POWER PACK OR TIMER BASE REPEATEDLY BLOWS ON SAME CYLINDER:**

1. Check the timer base wires for shorts to engine ground as a shorted timer base wire can destroy a SCR inside the power pack.
2. In contrast, a shorted SCR inside the power pack can destroy a timer base coil. Check the timer base resistance and DVA output (see NO SPARK ON ANY CYLINDER above).
3. Replace the ignition coil on the cylinder dropping spark.

### **ENGINE WILL NOT SHUT OFF:**

Disconnect the stop wire at the power pack. Connect a jumper wire to the stop wire from the pack and short it to engine ground. If this stops the pack from sparking, the stop circuit has a fault. Check the key switch, harness and shift switch. If this does not stop the pack from sparking, replace the power pack.

### **MISS AT ANY RPM:**

1. Disconnect the Yellow wires from the stator to the rectifier and retest. If the miss clears, replace the rectifier.
2. In the water or on a Dynameters, check the DVA output on the Orange wires from the power pack while connected to the ignition coils. You should have a reading of at least 150V DVA or more, increasing with engine RPM until it reaches 300-400V DVA maximum. A sharp drop in DVA right before the miss becomes apparent on all cylinders will normally be caused by a bad stator. A sharp drop in DVA on less than all cylinders will normally be the power pack or timer base.
3. Connect an inductive tachometer to each cylinder in turn and try to isolate the problem. A high variance in RPM on one cylinder usually indicates a problem in the power pack or ignition coil. Occasionally a timer base will cause this same problem. Check the timer base DVA voltage (see NO SPARK ON ANY CYLINDER above).
4. Perform a high-speed shutdown and read the spark plugs. Check for water. A crack in the block can cause a miss at high speed when the water pressure gets high, but a normal shutdown will mask the problem.
5. Check the triggering and charge coil flywheel magnets for cracked, broken and loose magnets.

### **ENGINE WILL NOT ACCELERATE BEYOND 2500 RPM (Runs smooth below that RPM):**

1. Use a temperature probe and verify that the engine is not overheating.
2. Disconnect the tan temperature wire from the pack and retest. If the engine now performs properly, the temperature switch is likely bad. Reconnect the Tan wire to the pack if it goes into the harness and disconnect the Tan wire from the temperature switch in the cylinder head. If the engine now performs normally, the temperature switch is defective. If it does not perform correctly, there is likely a problem in the engine harness, VRO (if equipped) or the boat harness.
3. Make sure the Tan temperature switch wire is not located next to a spark plug wire (RF interference can activate the SLOW function without sounding the warning horn.)

### **ENGINE DIES WHEN QUICK-START DROPS OUT:**

Check ignition timing at idle with the White/Black temperature wire disconnected. Remember to allow for the drop in ignition timing when Quick-Start disengages. Verify ignition timing after engine has warmed up.

### **ENGINE STAYS IN QUICK-START:**

1. With the engine idling, check the Yellow/Red wire for DC voltage. If there is DC voltage over 2 volts on this wire while the engine is running, the Quick-Start will not disengage. A voltage of 5 to 7 volts will not engage the starter solenoid, yet will engage Quick-Start.
2. Short the White/Black temperature switch wire FROM the power pack to engine ground. Start the engine, if the Quick-Start drops out after approximately 5 seconds; replace the White/Black temperature switch.
3. Disconnect the Black/White wire from the power pack. If the Quick-Start feature is not now working, replace the power pack.

### **ENGINE WILL NOT ENGAGE QUICK-START:**

1. Disconnect the White/Black wire from the temperature sensor.
2. With the engine idling, check the Black/White timer base wire for DVA voltage. There should be about 6 to 10 volts on this wire while the engine is running for the Quick-Start to engage. If the voltage is not present, verify the power coil DVA voltage is between 10 and 22 volts from the Orange to Orange/Black connected. If the DVA is correct on the Orange to Orange/Black wires, but the DVA on the Black/White is not, replace the power pack. If the Black/White wire has the correct DVA voltage, but QuickStart does not work, replace the timerbase.

## **Johnson/Evinrude Troubleshooting**

### **ENGINE TIMING TOO HIGH:**

1. Check the flywheel center hub magnet to make sure it's tight. Look for signs of cracks and bulges in the Brown ferret magnet material.
2. Short the White/Black temp wire to engine ground and see if the timing drops back to normal.
3. Check the DC voltage on the Black/White wire going to the timer base. With the White/Black temp wire disconnected, the voltage should be 6 to 10 volts. When the White/Black temp wire is shorted to engine ground, the voltage should drop out. If the voltage on the Black/White wire stays in the 6-10 volt range, disconnect the Yellow/Red wire from the power pack. The voltage should drop out on the Black/White wire. If it does, the harness or starter solenoid is likely defective. If the voltage on the Black/White wire stays in the 6-10 volt range with the Yellow/Red wire disconnected and the White/Black wire shorted to engine ground, the power pack is defective.

### **Four Cylinder Engines (Without Quick-Start) 1978-1987 85-140 HP Dual Power Pack Engines**

**Service Note:** Please use the Factory recommended spark plug (currently Champion QL77JC4) gapped at 0.030".

### **NO SPARK ON ANY CYLINDER:**

1. Disconnect the Black/Yellow stop wire(s) AT THE POWER PACK(S) and retest. If the engine's ignition has spark, the stop circuit has a fault. Check the key switch, harness and shift switch.
2. Disconnect the Yellow wires from the rectifier and retest. If the engine has spark, replace the rectifier.
3. Check the cranking RPM. A cranking speed of less than 250-RPM will not allow the system to spark properly. This can be caused by a weak battery, dragging starter, bad battery cables or a mechanical problem inside the engine.
4. Inspect and clean all engine and ignition ground connections.
5. Check the stator and timer base resistance and DVA output as given below for BOTH banks:

| WIRE        | READ TO      | OHMS (OEM) | OHMS(CDI) | DVA (Connected) | DVA (Disconnected) |
|-------------|--------------|------------|-----------|-----------------|--------------------|
| Brown       | Brown/Yellow | 485-635    | 530-630   | 150-400 V       | 150-400 V (*)      |
| White       | Blue         | 30-50      | 27-36     | 0.6 V +         | 0.6 V + (#)        |
| White       | Green        | 30-50      | 27-36     | 0.6 V +         | 0.6 V + (#)        |
| White/Black | Blue/White   | 30-50      | 27-36     | 0.6 V +         | 0.6 V + (#)        |
| White/Black | Green/White  | 30-50      | 27-36     | 0.6 V +         | 0.6 V + (#)        |

(\*) This reading can be used to determine if a stator or pack has a problem. For instance, if you have no spark on any cylinder and the stator's DVA reading is out of spec – disconnect the stator wires and recheck the DVA output. If the reading is still out of spec – the stator is bad. If the reading is now within spec – the pack is bad.

(#) This reading can be used to determine if a pack has a problem in the triggering circuit. For instance, if you have no spark on one cylinder and the timer base's DVA reading for that cylinder is low – disconnect the timer base wires and recheck the DVA output. If the reading stays low – the timer base is bad. If the reading is now within spec – the pack is bad.

6. Check the triggering and charge coil flywheel magnets for cracked, broken and loose magnets.

### **NO SPARK OR INTERMITTENT SPARK ON ONE CYLINDER OR ONE BANK:**

1. Disconnect the stop wires from both power packs and retest. If spark returns, swap the power packs and reconnect the stop circuit. If the no spark problem remains on the same bank, the stop circuit has a fault. If the problem moves, replace the power pack that was firing correctly due to a bad blocking diode in the pack.
2. Swap the stator wire pairs from one side of the engine to the other side and see if the problem moves. If it does, the stator is bad.
3. Check the stator and timer base resistance and DVA output on BOTH banks (see NO SPARK ON ANY CYLINDER above).
4. Check the DVA output on the Orange wires from the power pack while connected to the ignition coils. You should have a reading of at least 150V or more. If the reading is low on one cylinder, disconnect the Orange wire from the ignition coil for that cylinder and reconnect it to a load resistor. Retest. If the reading is now good, the ignition coil is likely bad. A continued low reading indicates a bad power pack.
5. Visually inspect the ignition coils for burned or discolored areas and cracks in the casing (indicating arcing inside the coil).
6. Swap the ignition coil with one that is sparking correctly.
7. Rare causes include a weak trigger magnet. If possible, try another flywheel.



## Johnson/Evinrude Troubleshooting

### POWER PACK OR TIMER BASE REPEATEDLY BLOWS ON SAME CYLINDER:

1. Check the timer base wires for shorts to engine ground as a shorted timer base wire can destroy a SCR inside the power pack.
2. In contrast, a shorted SCR inside the power pack can destroy a timer base coil. Check the timer base resistance and DVA output (see NO SPARK ON ANY CYLINDER).
3. Replace the ignition coil on the cylinder dropping spark.

### ENGINE WILL NOT SHUT OFF:

Disconnect the stop wire at the power pack. Connect a jumper wire to the stop wire from the pack and short it to engine ground. If this stops the pack from sparking, the stop circuit has a fault. Check the key switch, harness and shift switch. If this does not stop the pack from sparking, replace the power pack. Repeat test as necessary for additional packs.

### MISS AT ANY RPM:

1. Disconnect the Yellow wires from the stator to the rectifier and retest. If the miss clears, replace the rectifier.
2. In the water or on a Dynameters, check the DVA output on the Orange wires from the power pack while connected to the ignition coils. You should have a reading of at least 150V DVA or more, increasing with engine RPM until it reaches 300-400V DVA maximum. A sharp drop in DVA right before the miss becomes apparent on all cylinders will normally be caused by a bad stator. A sharp drop in DVA on less than all cylinders will normally be the power pack or timer base.
3. Connect an inductive tachometer to each cylinder in turn and try to isolate the problem. A high variance in RPM on one cylinder usually indicates a problem in the power pack or ignition coil. Occasionally a timer base will cause this same problem. Check the timer base DVA voltage (see NO SPARK ON ANY CYLINDER above).
4. Perform a high-speed shutdown and read the spark plugs. Check for water. A crack in the block can cause a miss at high speed when the water pressure gets high, but a normal shutdown will mask the problem.
5. Check the triggering and charge coil flywheel magnets for cracked, broken and loose magnets.

### ENGINE MISSES OR HAS ERRATIC TIMING:

1. Disconnect the Black/Yellow stop wire(s) AT THE POWER PACK(S) and retest. If the engine runs normally, the stop circuit could have a fault. Check the key switch, harness and shift switch. If all check good, replace the power pack. (For engines with dual power packs, replace BOTH power packs at the same time).
2. Check the stator and timer base resistance and DVA output (see NO SPARK ON ANY CYLINDER above).

### ***Four Cylinder Engines (Without Quick-Start)*** **1985-1987 65-140 HP Single Power Pack Engines**

Service Note: Please use the Factory recommended spark plug (currently Champion QL77JC4) gapped at 0.030".

### NO SPARK ON ANY CYLINDER:

1. Disconnect the Black/Yellow stop wire(s) AT THE POWER PACK(S) and retest. If the engine's ignition has spark, the stop circuit has a fault. Check the key switch, harness and shift switch.
2. Disconnect the Yellow wires from the rectifier and retest. If the engine has spark, replace the rectifier.
3. Check the cranking RPM. A cranking speed of less than 250-RPM will not allow the system to spark properly. This can be caused by a weak battery, dragging starter, bad battery cables or a mechanical problem inside the engine.
4. Inspect and clean all engine and ignition ground connections.
5. Check the stator and timer base resistance and DVA output as given below for BOTH banks:

| WIRE  | READ TO      | OEM Ohms | CDI Ohms | DVA (Connected) | DVA (Disconnected) |
|-------|--------------|----------|----------|-----------------|--------------------|
| Brown | Brown/Yellow | 450-550  | 530-630  | 150-400 V       | 150-400 V (*)      |
| White | Purple       | 30-50    | 38-48    | 0.6 V +         | 0.6 V + (#)        |
| White | Blue         | 30-50    | 38-48    | 0.6 V           | 0.6 V + (#)        |
| White | Green        | 30-50    | 38-48    | 0.6 V +         | 0.6 V + (#)        |
| White | Pink         | 30-50    | 38-48    | 0.6 V +         | 0.6 V + (#)        |

(\*) This reading can be used to determine if a stator or pack has a problem. For instance, if you have no spark on any cylinder and the stator's DVA reading is out of spec – disconnect the stator wires and recheck the DVA output. If the reading is still out of spec – the stator is bad. If the reading is now within spec – the pack is bad.



## **Johnson/Evinrude Troubleshooting**

(#) This reading can be used to determine if a pack has a problem in the triggering circuit. For instance, if you have no spark on one cylinder and the timer base's DVA reading for that cylinder is low – disconnect the timer base wires and recheck the DVA output. If the reading stays low – the timer base is bad. If the reading is now within spec – the pack is bad.

6. Check the triggering and charge coil flywheel magnets for cracked, broken and loose magnets.

### **NO SPARK OR INTERMITTENT SPARK ON ONE CYLINDER OR ONE BANK:**

1. Swap the stator's Brown for Brown/Yellow and see if the problem moves. If it does, the stator is bad.
2. Check the stator and timer base resistance and DVA output (see NO SPARK ON ANY CYLINDER above).
3. Check the DVA output on the Orange wires from the power pack while connected to the ignition coils. You should have a reading of at least 150V or more. If the reading is low on one cylinder, disconnect the Orange wire from the ignition coil for that cylinder and reconnect it to a load resistor. Retest. If the reading is now good, the ignition coil is likely bad. A continued low reading indicates a bad power pack or timer base.
4. Visually inspect the ignition coils for burned or discolored areas and cracks in the casing (indicating arcing inside the coil).
5. Swap the ignition coil with one that is sparking correctly.
6. Rare causes include a weak trigger magnet. If possible, try another flywheel.

### **POWER PACK OR TIMER BASE REPEATEDLY BLOWS ON SAME CYLINDER:**

1. Check the timer base wires for shorts to engine ground as a shorted timer base wire can destroy a SCR inside the power pack.
2. In contrast, a shorted SCR inside the power pack can destroy a timer base coil. Check the timer base resistance and DVA output (see NO SPARK ON ANY CYLINDER above).
3. Replace the ignition coil on the cylinder dropping spark.

### **ENGINE WILL NOT SHUT OFF:**

Disconnect the stop wire at the power pack. Connect a jumper wire to the stop wire from the pack and short it to engine ground. If this stops the pack from sparking, the stop circuit has a fault. Check the key switch, harness and shift switch. If this does not stop the pack from sparking, replace the power pack.

### **MISS AT ANY RPM:**

1. Disconnect the Yellow wires from the stator to the rectifier and retest. If the miss clears, replace the rectifier.
2. In the water or on a Dynameters, check the DVA output on the Orange wires from the power pack while connected to the ignition coils. You should have a reading of at least 150V DVA or more, increasing with engine RPM until it reaches 300-400V DVA maximum. A sharp drop in DVA right before the miss becomes apparent on all cylinders will normally be caused by a bad stator. A sharp drop in DVA on less than all cylinders will normally be the power pack or timer base.
3. Connect an inductive tachometer to each cylinder in turn and try to isolate the problem. A high variance in RPM on one cylinder usually indicates a problem in the power pack or ignition coil. Occasionally a timer base will cause this same problem. Check the timer base DVA voltage (see NO SPARK ON ANY CYLINDER above).
4. Perform a high-speed shutdown and read the spark plugs. Check for water. A crack in the block can cause a miss at high speed when the water pressure gets high, but a normal shutdown will mask the problem.
5. Check the triggering and charge coil flywheel magnets for cracked, broken and loose magnets.

### **ENGINE MISSES OR HAS ERRATIC TIMING:**

1. Disconnect the Black/Yellow stop wire(s) AT THE POWER PACK(S) and retest. If the engine runs normally, the stop circuit could have a fault. Check the key switch, harness and shift switch. If all check good, replace the power pack. (For engines with dual power packs, replace BOTH power packs at the same time).
2. Check the stator and timer base resistance and DVA output (see NO SPARK ON ANY CYLINDER above).

## Johnson/Evinrude Troubleshooting

### Four Cylinder Engines (Without Quick-Start)

#### 1988-1997 65-140 HP Single Power Pack Engines

Service Note: Please use the Factory recommended spark plug (currently Champion QL77JC4/QL78YC) gapped at 0.030".

#### NO SPARK ON ANY CYLINDER:

1. Disconnect the Black/Yellow stop wire(s) AT THE POWER PACK(S) and retest. If the engine's ignition has spark, the stop circuit has a fault. Check the key switch, harness and shift switch.
2. Disconnect the Yellow wires from the rectifier and retest. If the engine has spark, replace the rectifier.
3. Check the cranking RPM. A cranking speed of less than 250-RPM will not allow the system to spark properly. This can be caused by a weak battery, dragging starter, bad battery cables or a mechanical problem inside the engine.
4. Inspect and clean all engine and ignition ground connections.
5. Check the stator and timer base resistance and DVA output as given below for BOTH banks:

| WIRE  | READ TO      | OEM Ohms | CDI Ohms | DVA (Connected) | DVA (Disconnected) |
|-------|--------------|----------|----------|-----------------|--------------------|
| Brown | Brown/Yellow | 510-620  | 530-630  | 150-400 V       | 150-400 V (*)      |
| White | Purple       | 30-50    | 38-48    | 0.6 V + (a)     | 0.6 V + (#)        |
| White | Blue         | 30-50    | 38-48    | 0.6 V + (a)     | 0.6 V + (#)        |
| White | Green        | 30-50    | 38-48    | 0.6 V + (a)     | 0.6 V + (#)        |
| White | Pink         | 30-50    | 38-48    | 0.6 V + (a)     | 0.6 V + (#)        |

(\*) This reading can be used to determine if a stator or pack has a problem. For instance, if you have no spark on any cylinder and the stator's DVA reading is out of spec – disconnect the stator wires and recheck the DVA output. If the reading is still out of spec – the stator is bad. If the reading is now within spec – the pack is bad.

(#) This reading can be used to determine if a pack has a problem in the triggering circuit. For instance, if you have no spark on one cylinder and the timer base's DVA reading for that cylinder is low – disconnect the timer base wires and recheck the DVA output. If the reading stays low – the timer base is bad. If the reading is now within spec – the pack is bad.

(a) Check stator DVA first. Then if timer base DVA is 0.6 - 2.5 V, the pack is faulty. If below 0.6 V or 2.6 - 99 V, the timer base is faulty.

6. Check the triggering and charge coil flywheel magnets for cracked, broken and loose magnets.

#### NO SPARK OR INTERMITTENT SPARK ON ONE CYLINDER OR ONE BANK:

1. Swap the stator's Brown for Brown/Yellow and see if the problem moves. If it does, the stator is bad.
2. Check the stator and timer base resistance and DVA output (see NO SPARK ON ANY CYLINDER above).
3. Check the DVA output on the Orange wires from the power pack while connected to the ignition coils. You should have a reading of at least 150V or more. If the reading is low on one cylinder, disconnect the Orange wire from the ignition coil for that cylinder and reconnect it to a load resistor. Retest. If the reading is now good, the ignition coil is likely bad. A continued low reading indicates a bad power pack or timer base.
4. Visually inspect the ignition coils for burned or discolored areas and cracks in the casing (indicating arcing inside the coil).
5. Swap the ignition coil with one that is sparking correctly.
6. Check the power pack resistance given below:

| Wire Color    | (CYL) | Check to Wire Color   | Resistance      |
|---------------|-------|-----------------------|-----------------|
| Orange/Blue   | (#1)  | Blue                  | 110 (a)         |
| Orange/Green  | (#3)  | Green                 | 110 (a)         |
| Orange/Violet | (#2)  | Purple                | 110 (a)         |
| Orange        | (#4)  | Pink                  | 110 (a)         |
| White         |       | Black (Engine Ground) | Shorted         |
| Brown         |       | Black (Engine Ground) | Open or M range |
| Brown/Yellow  |       | Black (Engine Ground) | Open or M range |

(a) Use a comparison reading as different brands of meters will give different readings. The typical range is 90 to 150 ohms for the Orange wires. You should have approximately the same ohm reading on all six tests with the Orange wires. If one of the SCR's inside the power pack is shorted or open, the readings will be quite a bit different.

7. Rare causes include a weak trigger magnet. If possible, try another flywheel.

## **Johnson/Evinrude Troubleshooting**

### **POWER PACK OR TIMER BASE REPEATEDLY BLOWS ON SAME CYLINDER:**

1. Check the timer base wires for shorts to engine ground as a shorted timer base wire can destroy a SCR inside the power pack.
2. In contrast, a shorted SCR inside the power pack can destroy a timer base coil. Check the timer base resistance and DVA output (see NO SPARK ON ANY CYLINDER above).
3. Replace the ignition coil on the cylinder dropping spark.

### **ENGINE WILL NOT SHUT OFF:**

Disconnect the stop wire at the power pack. Connect a jumper wire to the stop wire from the pack and short it to engine ground. If this stops the pack from sparking, the stop circuit has a fault. Check the key switch, harness and shift switch. If this does not stop the pack from sparking, replace the power pack.

### **MISS AT ANY RPM:**

1. Disconnect the Yellow wires from the stator to the rectifier and retest. If the miss clears, replace the rectifier.
2. In the water or on a Dynameters, check the DVA output on the Orange wires from the power pack while connected to the ignition coils. You should have a reading of at least 150V DVA or more, increasing with engine RPM until it reaches 300-400V DVA maximum. A sharp drop in DVA right before the miss becomes apparent on all cylinders will normally be caused by a bad stator. A sharp drop in DVA on less than all cylinders will normally be the power pack or timer base.
3. Connect an inductive tachometer to each cylinder in turn and try to isolate the problem. A high variance in RPM on one cylinder usually indicates a problem in the power pack or ignition coil. Occasionally a timer base will cause this same problem. Check the timer base DVA voltage (see NO SPARK ON ANY CYLINDER above).
4. Perform a high-speed shutdown and read the spark plugs. Check for water. A crack in the block can cause a miss at high speed when the water pressure gets high, but a normal shutdown will mask the problem.
5. Check the triggering and charge coil flywheel magnets for cracked, broken and loose magnets.

### **ENGINE MISSES OR HAS ERRATIC TIMING:**

1. Disconnect the Black/Yellow stop wire(s) AT THE POWER PACK(S) and retest. If the engine runs normally, the stop circuit could have a fault. Check the key switch, harness and shift switch. If all check good, replace the power pack. (For engines with dual power packs, replace BOTH power packs at the same time).
2. Check the stator and timer base resistance and DVA output (see NO SPARK ON ANY CYLINDER on the previous page).

## Johnson/Evinrude Troubleshooting

### Four Cylinder Engines

#### (1988-2001 120-140 HP Quick-Start Models)

Service Note: Please use the Factory recommended spark plug (currently Champion QL77JC4/QL78YC) gapped at 0.030".

#### NO SPARK ON ANY CYLINDER:

NOTE: These engines use a gear reduction starter which results in a lower cranking RPM than usual. If you have one or more cylinders intermittent at cranking: Try starting the engine and checking to see if ALL of the cylinders now fire correctly. If so, the engine's ignition should be good. Make sure the battery is sized correctly as the cranking capacity can affect the cranking speed.

1. Disconnect the Black/Yellow kill wire FROM THE PACK and retest. If the engine's ignition now has fire, the kill circuit has a fault-possibly the key switch, harness or shift switch.
2. Disconnect the Yellow wires from the stator to the rectifier and retest. If the engine fires, replace the rectifier.
3. Check the stator and trigger resistance and DVA output as given below for each bank:

| Wire Color   | Check to Wire Color   | OEM Ohms | CDI Ohms | DVA Reading (Connected) (Disconnected) |        |
|--------------|-----------------------|----------|----------|--|--------|
| Brown        | Brown/Yellow (9 Amp)  | 455-505  | 530-630  | 150V +                                 | 175V + |
| Brown        | Brown/Yellow (35 Amp) | 850-1100 | 850-1100 | 150V +                                 | 175V + |
| Orange       | Orange/Black          | 90-110   | 90-110   | 12-24V                                 | 50V +  |
| Blue         | White                 | 35-55    | 38-48    | 0.5V                                   |        |
| Purple       | White                 | 35-55    | 38-48    | 0.5V                                   |        |
| Green        | White                 | 35-55    | 38-48    | 0.5V                                   |        |
| Pink         | White                 | 35-55    | 38-48    | 0.5V                                   |        |
| Blue/White   | White                 | 100-160  | 100-160  | 1.2V                                   |        |
| Purple/White | White                 | 100-160  | 100-160  | 1.2V                                   |        |
| Green/White  | White                 | 100-160  | 100-160  | 1.2V                                   |        |
| Pink/White   | White                 | 100-160  | 100-160  | 1.2V                                   |        |

4. Check the center hub triggering magnet in the flywheel. A loose or broken magnet can cause this problem.
5. Check the cranking RPM. A cranking speed of less than 250-RPM will not allow the system to fire properly. This can be caused by a weak battery, dragging starter, bad battery cables or a mechanical problem inside the engine.

#### NO SPARK ON ONE CYLINDER:

1. Check the Timer Base resistance and output (see NO SPARK ON ANY CYLINDER above).
2. Check the DVA output on the Orange wires from the power pack while connected to the ignition coils. You should have a reading of at least 130V or more. If the reading is low on one cylinder, disconnect the Orange wire from the ignition coil for that cylinder and reconnect it to a load resistor. Retest. If the reading is now good, the ignition coil is likely bad.
3. Check the Timer Base resistance given below:

| Wire Color   | Check to Wire Color | OEM Ohms | CDI Ohms | DVA Reading |
|--------------|---------------------|----------|----------|-------------|
| Blue         | White               | 35-55    | 38-48    | 0.5V        |
| Purple       | White               | 35-55    | 38-48    | 0.5V        |
| Green        | White               | 35-55    | 38-48    | 0.5V        |
| Pink         | White               | 35-55    | 38-48    | 0.5V        |
| Blue/White   | White               | 100-160  | 100-160  | 1.2V        |
| Purple/White | White               | 100-160  | 100-160  | 1.2V        |
| Green/White  | White               | 100-160  | 100-160  | 1.2V        |
| Pink/White   | White               | 100-160  | 100-160  | 1.2V        |

4. Check the spark plug wires for breaks and abrasions.

#### ENGINE DIES WHEN QUICKSTART DROPS OUT:

Check ignition timing at idle with the White/Black temperature wire disconnected. Remember to allow for the 12-15 Degree drop in ignition timing when Quick Start disengages. Verify ignition timing after engine has warmed up, according to the service manual.

## **Johnson/Evinrude Troubleshooting**

### **ENGINE WILL NOT STAY IN QUICKSTART OVER 10 SECONDS:**

1. Verify the engine temperature is below the trip point (89 degrees on some engines and 104 degrees on others) of the temperature switch.
2. Disconnect the White/Black Temperature Switch wire FROM the Port Temperature Switch. If the engine now stays in QuickStart, the Temperature Switch is likely defective.

### **ENGINE STAYS IN QUICKSTART ON ALL CYLINDERS:**

1. With the engine idling, check the Yellow/Red wire for DC voltage. If there is DC voltage on this wire while the engine is running, the Quick-Start will not disengage. A voltage over 1.5 volts but less than 7 volts will not engage the starter solenoid, yet will engage Quick-Start.
2. Short the White/Black Temperature Switch wire FROM the power pack to engine ground. Start the engine, if the Quick Start drops out after approximately 5 seconds, replace the White/Black Temperature Switch.
3. If the only way to disable QuickStart is to disconnect the 4pin connector with the Blue/White, Purple/White, Green/White and Pink/White wires between the power pack and the Timer Base, replace the power pack.

### **ENGINE DROPS OUT AND BACK IN QUICKSTART AT IDLE:**

1. Verify the spark plugs are the Champion QL77JC4 or QL78YC. These plugs are INDUCTIVE – NOT Resistive RF suppression.
2. Check the engine RPM,
3. With the engine idling, check the Yellow/Red wire for DC voltage. Intermittent DC voltage on this wire while the engine is running will re-engage Quick-Start. A voltage of less than 7 volts will not engage the starter solenoid, yet will engage Quick-Start.
4. With the engine idling, disconnect the Black/White wire from the power pack and short the White/Black Temperature Switch wire FROM the power pack to engine ground. If the Quick Start drops out and stays out after approximately 5 seconds, replace the White/Black Temperature Switch. If the problem is still present, replace the power pack.

### **NO SPARK ON ONE BANK:**

1. Swap pin location of the two Brown wires from the stator and retest. If the problem moves, the stator has a fault.
2. Disconnect the yellow wires from the stator to the rectifier and retest. If the engine fires, replace the rectifier.
3. Check the Timer Base resistance given below:

| Wire Color   | Check to Wire Color | OEM Ohms | CDI Ohms | DVA Reading (Connected) |
|--------------|---------------------|----------|----------|-------------------------|
| Blue         | White               | 35-55    | 38-48    | 0.5V                    |
| Purple       | White               | 35-55    | 38-48    | 0.5V                    |
| Green        | White               | 35-55    | 38-48    | 0.5V                    |
| Pink         | White               | 35-55    | 38-48    | 0.5V                    |
| Blue/White   | White               | 100-160  | 100-160  | 1.2V                    |
| Purple/White | White               | 100-160  | 100-160  | 1.2V                    |
| Green/White  | White               | 100-160  | 100-160  | 1.2V                    |
| Pink/White   | White               | 100-160  | 100-160  | 1.2V                    |

4. Check the spark plug wires for breaks and abrasions.
5. Check the cranking RPM. A cranking speed of less than 250-RPM will not allow the system to fire properly. This can be caused by a weak battery, dragging starter, bad battery cables or a mechanical problem inside the engine.
6. Check the DVA output on the orange wires from the power pack while connected to the ignition coils. You should have a reading of at least 150V or more. If the reading is low on one bank, disconnect the orange wires from the ignition coil for that bank and reconnect them to a load resistor. Retest. If the reading is now good, one or all of the ignition coils are likely bad. A continued low reading indicates a bad power pack.

### **ENGINE WILL NOT ACCELERATE BEYOND 2500 RPM (Runs smooth below that RPM):**

1. Use a temperature probe and verify that the engine is not overheating.
2. Verify the correct spark plugs are installed.
3. Make sure the tan temperature switch wire is not located next to a spark plug wire.
4. Disconnect the tan temperature wire from the pack and retest. If the engine now performs properly, the temperature switch, VRO switch or engine harness is likely defective.
5. Disconnect the VRO sensor from the engine harness and retest. If the engine performs correctly, replace the VRO or sensor.



## Johnson/Evinrude Troubleshooting

### ENGINE ENGAGES S.L.O.W. (Limits at 2500 PM) WHEN THE NO OIL, LOW OIL OR FUEL VACUUM ALARM SOUNDS:

1. Disconnect engine harness.
2. Disconnect the Tan wires from the temperature sensors in both cylinder heads.
3. Using an VOM Meter, check the diode in the engine harness as follows:

| Red Meter Lead                      | Black Meter Lead                    | Approximate Reading |
|-------------------------------------|-------------------------------------|---------------------|
| Tan pin in Engine Harness Connector | Tan Lead From Port Cyl Head         | 0.500               |
| Tan pin in Engine Harness Connector | Tan Lead From Stbd Cyl Head         | 0.500               |
| Tan Lead From Stbd Cyl Head         | Tan pin in Engine Harness Connector | OL or over 1.0      |
| Tan Lead From Port Cyl Head         | Tan pin in Engine Harness Connector | OL or over 1.0      |

NOTE: You can replace the diode in the harness with a 1N4007 diode available at most electronics stores.

### Six Cylinder Engines (Without Quick-Start) 1979-1988 150-235 HP Dual Power Pack Engines

Service Note: Please use the Factory recommended spark plug (currently Champion QL77JC4) gapped at 0.030".

#### NO SPARK ON ANY CYLINDER:

1. Disconnect the Black/Yellow stop wires AT THE POWER PACKS and retest. If the engine's ignition has spark, the stop circuit has a fault. Check the key switch, harness and shift switch.
2. Disconnect the Yellow wires from the rectifier and retest. If the engine now has spark, replace the rectifier.
3. Check the cranking RPM. A cranking speed of less than 250-RPM will not allow the system to spark properly. This is usually caused by a weak battery or dragging starter. Connect a battery charger on its highest setting to the battery and retest. If good spark, replace the starter and/or battery with an 850+ CCA cranking/dual purpose non-maintenance-free type.
4. Inspect and clean all engine and ignition ground connections.
5. Check the stator and timer base resistance and DVA output as given below for BOTH banks:

| WIRE  | READ TO      | OEM Ohms          | CDI Ohms | DVA (Connected) (Disconnected) |               |
|-------|--------------|-------------------|----------|--------------------------------|---------------|
| Brown | Brown/Yellow | 485-635 (9 Amp)   | 530-630  | 150-400 V                      | 150-400 V (*) |
| Brown | Brown/Yellow | 950-1100 (35 Amp) | 900-1100 | 150-400 V                      | 150-400 V (*) |
| White | Purple       | 15-50 (a)         |          | 0.6 V +                        | 0.6 V + (#)   |
| White | Blue         | 15-50 (a)         |          | 0.6 V +                        | 0.6 V + (#)   |
| White | Green        | 15-50 (a)         |          | 0.6 V +                        | 0.6 V + (#)   |

(\*) This reading can be used to determine if a stator or pack has a problem. For instance, if you have no spark on any cylinder and the stator's DVA reading is out of spec – disconnect the stator wires and recheck the DVA output. If the reading is still out of spec – the stator is bad. If the reading is now within spec – the pack is bad.

(#) This reading can be used to determine if a pack has a problem in the triggering circuit. For instance, if you have no spark on one cylinder and the timer base's DVA reading for that cylinder is low – disconnect the timer base wires and recheck the DVA output. If the reading stays low – the timer base is bad. If the reading is now within spec – the pack is bad.

(a) Use a comparison reading as the values for different years used different coils in the timer base. As long as you have approximately the same ohm reading on all three tests and the correct output with the DVA meter for both sides, the timer base should be good. The exception would be if the insulation is breaking down while the engine is running.

6. Check the triggering and charge coil flywheel magnets for cracked, broken and loose magnets.

#### NO SPARK OR INTERMITTENT SPARK ON ONE BANK:

1. Swap the stator wire pairs from one side of the engine to the other side and see if the problem moves. If it does, the stator is bad.
2. Disconnect the stop wires from both power packs and retest. If the spark returns, swap the power packs and reconnect the stop circuit. If the no spark problem remains on the same bank, the stop circuit has a fault. If the problem moves, replace the power pack that was firing correctly due to a bad blocking diode in the pack.
3. Check the stator and timer base resistance and DVA output for BOTH banks (see NO SPARK ON ANY CYLINDER above).

## **Johnson/Evinrude Troubleshooting**

4. Check the DVA voltage to engine ground on the White timer base wire while connected to the pack. You should see approximately the same reading as you do between the Brown & Brown/Yellow wires for that bank. A low reading usually indicates a bad timer base.

### **NO SPARK OR INTERMITTENT SPARK ON ONE OR MORE CYLINDERS:**

1. Check the cranking RPM. A cranking speed of less than 250-RPM will not allow the system to spark properly. This is usually caused by a weak battery or dragging starter. Connect a battery charger on its highest setting to the battery and retest. If good spark, replace the starter and/or battery with an 850+ CCA cranking/dual purpose non-maintenance-free type.
2. Check the DVA output on the Orange wires from the power pack while connected to the ignition coils. You should have a reading of at least 150V or more. If the reading is low on one cylinder, disconnect the Orange wire from the ignition coil for that cylinder and reconnect it to a load resistor. Retest. If the reading is now good, the ignition coil is likely bad. A continued low reading indicates a bad power pack or timer base.
3. Check the timer base resistance and DVA output for BOTH banks (see NO SPARK ON ANY CYLINDER above).
4. Visually inspect the ignition coils for burned or discolored areas and cracks in the casing (indicating arcing inside the coil).
5. Swap the ignition coil with one that is sparking correctly.
6. Rare causes include a weak trigger magnet. If possible, try another flywheel.
7. Swap banks with the power packs and see if the problem moves. If it does, replace the power pack. If not, replace the timer base.

### **POWER PACK OR TIMER BASE REPEATEDLY BLOWS ON SAME CYLINDER:**

1. Check the timer base wires for shorts to engine ground as a shorted timer base wire can destroy a SCR inside the power pack.
2. In contrast, a shorted SCR inside the power pack can destroy a timer base coil. Check the timer base resistance and DVA output (see NO SPARK ON ANY CYLINDER above).
3. Replace the ignition coil on the cylinder dropping spark.

### **ENGINE WILL NOT SHUT OFF:**

Disconnect the stop wire at the power pack. Connect a jumper wire to the stop wire from the pack and short it to engine ground. If this stops the pack from sparking, the stop circuit has a fault. Check the key switch, harness and shift switch. If this does not stop the pack from sparking, replace the power pack. Repeat test as necessary for additional packs.

### **MISS AT ANY RPM:**

1. Disconnect the Yellow wires from the stator to the rectifier and retest. If the miss clears, replace the rectifier.
2. In the water or on a Dynameters, check the DVA output on the Orange wires from the power pack while connected to the ignition coils. You should have a reading of at least 150V DVA or more, increasing with engine RPM until it reaches 300-400V DVA maximum. A sharp drop in DVA right before the miss becomes apparent on all cylinders will normally be caused by a bad stator. A sharp drop in DVA on less than all cylinders will normally be the power pack or timer base.
3. Connect an inductive tachometer to each cylinder in turn and try to isolate the problem. A high variance in RPM on one cylinder usually indicates a problem in the power pack or ignition coil. Occasionally a timer base will cause this same problem. Check the timer base DVA voltage (see NO SPARK ON ANY CYLINDER above).
4. Perform a high-speed shutdown and read the spark plugs. Check for water. A crack in the block can cause a miss at high speed when the water pressure gets high, but a normal shutdown will mask the problem.
5. Check the triggering and charge coil flywheel magnets for cracked, broken and loose magnets.

### **ENGINE MISSES OR HAS ERRATIC TIMING:**

1. Disconnect the Black/Yellow stop wires AT THE POWER PACKS and retest. If the engine runs normally, the stop circuit could have a fault. Check the key switch, harness and shift switch. If all check good, replace BOTH power packs at the same time.
2. Check the stator and timer base resistance and DVA output for BOTH banks (see NO SPARK ON ANY CYLINDER above).

## Johnson/Evinrude Troubleshooting

### Six Cylinder Engines (Without Quick-Start)

#### 1989-1991 150 HP Single Power Pack Engines (With 583816/584044 Power Pack)

Service Note: Please use the Factory recommended spark plug (currently Champion QL77JC4) gapped at 0.030".

#### NO SPARK ON ANY CYLINDER:

1. Disconnect the Black/Yellow stop wire AT THE POWER PACK and retest. If the engine's ignition has spark, the stop circuit has a fault. Check the key switch, harness and shift switch.
2. Disconnect the Yellow wires from the rectifier and retest. If the engine now has spark, replace the rectifier.
3. Check the cranking RPM. A cranking speed of less than 250-RPM will not allow the system to spark properly. This is usually caused by a weak battery or dragging starter. Connect a battery charger on its highest setting to the battery and retest. If good spark, replace the starter and/or battery with an 850+ CCA cranking/dual purpose non-maintenance-free type.
4. Inspect and clean all engine and ignition ground connections.
5. Check the stator and timer base resistance and DVA output as given below for BOTH banks:

| WIRE        | READ TO                     | OEM Ohms  | CDI Ohms | DVA (Connected) | (Disconnected) |
|-------------|-----------------------------|-----------|----------|-----------------|----------------|
| Brown       | Brown/Yellow (1st Pair) (c) | 455-505   | 530-630  | 150-400 V       | 150-400 V (*)  |
| Brown/White | Brown/Black (2nd Pair) (c)  | 455-505   | 530-630  | 150-400 V       | 150-400 V (*)  |
| Black       | Purple                      | 30-50 (b) | 38-58    | 100-400 V (a)   | 0.6 V + (#)    |
| Black       | Blue                        | 30-50 (b) | 38-58    | 100-400 V (a)   | 0.6 V + (#)    |
| Black       | Green                       | 30-50 (b) | 38-58    | 100-400 V (a)   | 0.6 V + (#)    |
| Black       | Purple/White                | 30-50 (b) | 38-58    | 100-400 V (a)   | 0.6 V + (#)    |
| Black       | Blue/White                  | 30-50 (b) | 38-58    | 100-400 V (a)   | 0.6 V + (#)    |
| Black       | Green/White                 | 30-50 (b) | 38-58    | 100-400 V (a)   | 0.6 V + (#)    |

(\*) This reading can be used to determine if a stator or pack has a problem. For instance, if you have no spark on any cylinder and the stator's DVA reading is out of spec – disconnect the stator wires and recheck the DVA output. If the reading is still out of spec – the stator is bad. If the reading is now within spec – the pack is likely bad.

(#) This reading can be used to determine if a pack has a problem in the triggering circuit. For instance, if you have no spark on one cylinder and the timer base's DVA reading for that cylinder is low – disconnect the timer base wires and recheck the DVA output. If the reading stays low – the timer base is bad. If the reading is now within spec – the pack is likely bad.

(a) Check stator DVA first. Then if timer base DVA is 0.6 - 2.5 V, the pack is faulty. If below 0.6 V or 2.6 - 99 V, the timer base is faulty.

(b) Use a comparison reading as the values for the coils in the timer base. As long as you have approximately the same ohm reading on all six tests and the correct output with the DVA meter for all leads, the timer base should be good. The exception would be if the insulation is breaking down while the engine is running.

(c) Wires must be paired correctly. If the wires are crossed between pairs, the resulting feedback will destroy the power pack.

6. Check the triggering and charge coil flywheel magnets for cracked, broken and loose magnets.

#### NO SPARK OR INTERMITTENT SPARK ON ONE BANK:

1. Disconnect BOTH of the Black/Yellow stop wires AT THE POWER PACK and retest. If the engine's ignition now has spark, the stop circuit has a fault. Check the key switch, harness and shift switch.
2. Swap the stator wire pairs from one side of the engine to the other side and see if the problem moves. If it does, the stator is bad.
3. Disconnect the Yellow wires from the stator to the rectifier and retest. If the engine sparks, replace the rectifier.
3. Check the cranking RPM. A cranking speed of less than 250-RPM will not allow the system to spark properly. This is usually caused by a weak battery or dragging starter. Connect a battery charger on its highest setting to the battery and retest. If good spark, replace the starter and/or battery with an 850+ CCA cranking/dual purpose non-maintenance-free type.
4. Check the stator resistance and DVA output for BOTH banks (see NO SPARK ON ANY CYLINDER above).
5. Check the DVA output on the Orange wires from the power pack while connected to the ignition coils. You should have a reading of at least 150V or more. If the reading is low on one bank, disconnect the Orange wires from the ignition coil for that bank and reconnect them to a load resistor. Retest. If the reading is now good, one or all of the ignition coils are likely bad. A continued low reading indicates a bad power pack.

## **Johnson/Evinrude Troubleshooting**

### **NO SPARK OR INTERMITTENT SPARK ON ONE OR MORE CYLINDERS:**

1. Check the cranking RPM. A cranking speed of less than 250-RPM may not allow the system to spark properly. This is usually caused by a weak battery or dragging starter. Connect a battery charger on its highest setting to the battery and retest. If good spark, replace the starter and/or battery with an 800+ CCA cranking/dual purpose non-maintenance-free type.
2. Check the DVA output on the Orange wires from the power pack while connected to the ignition coils. You should have a reading of at least 150V or more. If the reading is low on one cylinder, disconnect the Orange wire from the ignition coil for that cylinder and reconnect it to a load resistor. Retest. If the reading is now good, the ignition coil is likely bad. A continued low reading indicates a bad power pack or timer base.
3. Check the stator and timer base resistance and DVA output for BOTH banks (see NO SPARK ON ANY CYLINDER above).
4. Visually inspect the ignition coils for burned or discolored areas and cracks in the casing (indicating arcing inside the coil).
5. Swap the ignition coil with one that is sparking correctly.
6. Rare causes include a weak trigger magnet. If possible, try another flywheel.
7. Identify the timer base wire responsible for the problem cylinder {remember that the color codes are Blue (sky) is up and Green (grass) is down} and swap it with one that is operating correctly. In order to run the engine, you will have to also swap the corresponding spark plug wire.

### **POWER PACK OR TIMER BASE REPEATEDLY BLOWS ON SAME CYLINDER:**

1. Check the timer base wires for shorts to engine ground as a shorted timer base wire can destroy a SCR inside the power pack.
2. In contrast, a shorted SCR inside the power pack can destroy a timer base coil. Check the timer base resistance and DVA output (see NO SPARK ON ANY CYLINDER above).
3. Replace the ignition coil on the cylinder dropping spark.

### **ENGINE WILL NOT SHUT OFF:**

Disconnect the stop wire at the power pack. Connect a jumper wire to the stop wire from the pack and short it to engine ground. If this stops the pack from sparking, the stop circuit has a fault. Check the key switch, harness and shift switch. If this does not stop the pack from sparking, the power pack is defective.

### **MISS AT ANY RPM:**

1. Disconnect the Yellow wires from the stator to the rectifier and retest. If the miss clears, replace the rectifier.
2. In the water or on a Dynameters, check the DVA output on the Orange wires from the power pack while connected to the ignition coils. You should have a reading of at least 150V DVA or more, increasing with engine RPM until it reaches 300-400V DVA maximum. A sharp drop in DVA right before the miss becomes apparent on all cylinders will normally be caused by a bad stator. A sharp drop in DVA on some cylinders on the same bank will normally be the power pack or timer base.
3. Connect an inductive tachometer to each cylinder in turn and try to isolate the problem. A high variance in RPM on one cylinder usually indicates a problem in the power pack or ignition coil. Occasionally a timer base will cause this same problem. Check the timer base DVA voltage (see NO SPARK ON ANY CYLINDER).
4. Perform a high-speed shutdown and read the spark plugs. Check for water. A crack in the block can cause a miss at high speed when the water pressure gets high, but a normal shutdown will mask the problem.
5. Check the triggering and charge coil flywheel magnets for cracked, broken and loose magnets.

### **Six Cylinder Engines**

#### **(1988-1992 150-175 HP GT Cross-Flow Quick-Start Models)**

Service Note: Please use the Factory recommended spark plug (currently Champion QL77JC4) gapped at 0.030". (Note) These engines usually have a 35 Amp battery charging capacity. Due to the size and weight of the flywheel magnets, it is highly recommended that you check to make sure both the triggering and charge magnets are still secure in the flywheel before you service the engine. A loose or broken magnet can be deadly to you or your pocketbook. It is a recommended you index the flywheel and check the timing on all cylinders when servicing these engines. Also check for static firing and intermittent spark.



## Johnson/Evinrude Troubleshooting

### NO SPARK ON ANY CYLINDER:

1. Disconnect BOTH of the Black/Yellow stop wires AT THE POWER PACK and retest. If the engine's ignition has spark, the stop circuit has a fault. Check the key switch, harness and shift switch.
2. Disconnect the Yellow wires from the stator to the rectifier and retest. If the engine sparks, replace the rectifier.
3. Check the cranking RPM. A cranking speed of less than 250-RPM will not allow the system to spark properly. This is usually caused by a weak battery or dragging starter. Connect a battery charger on its highest setting to the battery and retest. If good spark, replace the starter and/or battery with an 850+ CCA cranking/dual purpose non-maintenance-free type.
4. Inspect and clean all engine and ignition ground connections.
5. Check the stator and timer base resistance and DVA output as given below for BOTH banks:

| WIRE        | READ TO                     | RESISTANCE | DVA (Connected) | DVA (Disconnected) |
|-------------|-----------------------------|------------|-----------------|--------------------|
| Brown       | Brown/Yellow (1st Pair) (d) | 900-1100   | 150-400 V       | 150-400 V (*)      |
| Brown/White | Brown/Black (2nd Pair) (d)  | 900-1100   | 150-400 V       | 150-400 V (*)      |
| Orange      | Orange/Black                | 93-103     | 11-22 V         | 45-120 V (*)       |
| White       | Purple                      | (c)        | 100-400 V (a)   | 0.6 V + (#)        |
| White       | Blue                        | (c)        | 100-400 V (a)   | 0.6 V + (#)        |
| White       | Green                       | (c)        | 100-400 V (a)   | 0.6 V + (#)        |
| White       | Purple (2nd connector)      | (c)        | 100-400 V (a)   | 0.6 V + (#)        |
| White       | Blue (2nd connector)        | (c)        | 100-400 V (a)   | 0.6 V + (#)        |
| White       | Green (2nd connector)       | (c)        | 100-400 V (a)   | 0.6 V + (#)        |
| White       | Black/White (2nd connector) | 215-230    | 6-10 V (b)      | 6-10 V (from pack) |

(\*) This reading can be used to determine if a stator or pack has a problem. For instance, if you have no spark on any cylinder and the stator's DVA reading is out of spec – disconnect the stator wires and recheck the DVA output. If the reading is still out of spec – the stator is bad. If the reading is now within spec – the pack is bad.

(#) This reading can be used to determine if a pack has a problem in the triggering circuit. For instance, if you have no spark on one cylinder and the timer base's DVA reading for that cylinder is low – disconnect the timer base wires and recheck the DVA output. If the reading stays low – the timer base is bad. If the reading is now within spec – the pack is bad.

(a) Check stator DVA first. Then if timer base DVA is 0.6 - 2.5 V, the pack is faulty. If below 0.6 V or 2.6 - 99 V, the timer base is faulty.

(b) DVA will drop below 1 V when the engine drops out of Quick-Start (engine is over 104 Degrees or 1200 RPM).

(c) Use a comparison reading as different brands of meters will give different readings. The typical range is 1M to 5M ohms. As long as you have approximately the same ohm reading on all six tests and the correct output with the DVA meter, the timer base should be good. Remember that temperature will affect the readings. The exception would be if one of the SCR's inside the timer base is breaking down while the engine is running. This can be found indexing the flywheel and checking the timing on all cylinders. If the readings are off, reverse the meter leads and retest to see if the readings are corrected.

(d) Wires must be paired correctly. If the wires are crossed between pairs, the resulting feedback will destroy the power pack.

6. Check the triggering and charge coil flywheel magnets for cracked, broken and loose magnets.

### NO SPARK OR INTERMITTENT SPARK ON ONE BANK:

1. Disconnect BOTH of the Black/Yellow stop wires AT THE POWER PACK and retest. If the engine's ignition now has spark, the stop circuit has a fault. Check the key switch, harness and shift switch.
2. Swap the stator wire pairs from one side of the engine to the other side and see if the problem moves. If it does, the stator is bad.
3. Disconnect the Yellow wires from the stator to the rectifier and retest. If the engine sparks, replace the rectifier.
4. Check the cranking RPM. A cranking speed of less than 250-RPM will not allow the system to spark properly. This is usually caused by a weak battery or dragging starter. Connect a battery charger on its highest setting to the battery and retest. If good spark, replace the starter and/or battery with an 850+ CCA cranking/dual purpose non-maintenance-free type.
5. Check the stator resistance and DVA output for BOTH banks (see NO SPARK ON ANY CYLINDER above).
6. Check the DVA output on the Orange wires from the power pack while connected to the ignition coils. You should have a reading of at least 150V or more. If the reading is low on one bank, disconnect the Orange wires from the ignition coil for that bank and reconnect them to a load resistor. Retest. If the reading is now good, one or all of the ignition coils are likely bad. A continued low reading indicates a bad power pack.



## **Johnson/Evinrude Troubleshooting**

### **NO SPARK OR INTERMITTENT SPARK ON ONE OR MORE CYLINDERS:**

1. Check the cranking RPM. A cranking speed of less than 250-RPM will not allow the system to spark properly. This is usually caused by a weak battery or dragging starter. Connect a battery charger on its highest setting to the battery and retest. If good spark, replace the starter and/or battery with an 850+ CCA cranking/dual purpose non-maintenance-free type.
2. Check the DVA output on the Orange wires from the power pack while connected to the ignition coils. You should have a reading of at least 150V or more. If the reading is low on one cylinder, disconnect the Orange wire from the ignition coil for that cylinder and reconnect it to a load resistor. Retest. If the reading is now good, the ignition coil is likely bad.
3. Check the timer base resistance and DVA output for BOTH banks (see NO SPARK ON ANY CYLINDER above).

4. Check the power pack resistance given below:

| Wire Color               | (CYL) | Check to Wire Color                                      | Resistance      |
|--------------------------|-------|--|-----------------|
| Orange/Blue              | (#1)  | Blue (in male 4 pin connector with White wire)           | 110 (a)         |
| Orange                   | (#3)  | Purple (in male 4 pin connector with White wire)         | 110 (a)         |
| Orange/Green             | (#5)  | Green (in male 4 pin connector with White wire)          | 110 (a)         |
| Orange/Blue              | (#2)  | Blue (in female 4 pin connector with Black/White wire)   | 110 (a)         |
| Orange                   | (#4)  | Purple (in female 4 pin connector with Black/White wire) | 110 (a)         |
| Orange/Green             | (#6)  | Green (in female 4 pin connector with Black/White wire)  | 110 (a)         |
| White (in pack)          |       | Black (Engine Ground)                                    | Shorted         |
| Brown, Brown/Yellow      |       | Black (Engine Ground)                                    | Open or M range |
| Brown/White, Brown/Black |       | Black (Engine Ground)                                    | Open or M range |
| Orange, Orange/Black     |       | Black (Engine Ground)                                    | Open or M range |

(a) Use a comparison reading as different brands of meters will give different readings. The typical range is 90 to 150 ohms. You should have approximately the same ohm reading on all six tests. If one of the SCR's inside the power pack is shorted or open, the readings will be quite a bit different.

5. Check the spark plug wires for breaks and abrasions.
6. Visually inspect the ignition coils for burned or discolored areas and cracks in the casing (indicating arcing inside the coil).
7. Swap the ignition coil with one that is sparking correctly.
8. Rare causes include a weak trigger magnet. If possible, try another flywheel.

### **POWER PACK OR TIMER BASE REPEATEDLY BLOWS ON SAME CYLINDER:**

1. Check the timer base wires for shorts to engine ground as a shorted timer base wire can destroy a SCR inside the power pack.
2. In contrast, a shorted SCR inside the power pack can destroy a timer base coil. Check the timer base resistance and DVA output (see NO SPARK ON ANY CYLINDER above).
3. Replace the ignition coil on the cylinder dropping spark.

### **ENGINE WILL NOT SHUT OFF:**

Disconnect the stop wires at the power pack. Connect a jumper wire to the stop wires from the pack and short it to engine ground. If this stops the pack from sparking, the stop circuit has a fault. Check the key switch, harness and shift switch. If this does not stop the pack from sparking, replace the power pack.

### **MISS AT ANY RPM:**

1. Disconnect the Yellow wires from the stator to the rectifier and retest. If the miss clears, replace the rectifier.
2. In the water or on a Dynameters, check the DVA output on the Orange wires from the power pack while connected to the ignition coils. You should have a reading of at least 150V DVA or more, increasing with engine RPM until it reaches 300-400V DVA maximum. A sharp drop in DVA right before the miss becomes apparent on all cylinders will normally be caused by a bad stator. A sharp drop in DVA on less than all cylinders will normally be the power pack or timer base.
3. Connect an inductive tachometer to each cylinder in turn and try to isolate the problem. A high variance in RPM on one cylinder usually indicates a problem in the power pack or ignition coil. Occasionally a timer base will cause this same problem. Check the timer base DVA voltage (see NO SPARK ON ANY CYLINDER above).
4. Perform a high-speed shutdown and read the spark plugs. Check for water. A crack in the block can cause a miss at high speed when the water pressure gets high, but a normal shutdown will mask the problem.
5. Check the triggering and charge coil flywheel magnets for cracked, broken and loose magnets.

## **Johnson/Evinrude Troubleshooting**

### **ENGINE WILL NOT ACCELERATE BEYOND 2500 RPM (Runs smooth below that RPM):**

1. Use a temperature probe and verify that the engine is not overheating.
2. Disconnect the tan warning system wire from the pack and retest. If the engine now performs properly, the temperature switch, VRO or harness may be bad. Reconnect the Tan wire to the pack and disconnect the Tan wire from the temperature switch in each cylinder head in turn. If the engine now performs normally, the temperature switch is defective. If it does not perform correctly, there is likely a problem in the engine harness, VRO (if equipped) or the boat harness.
3. Make sure the tan temperature switch wire is not located next to a spark plug wire.
4. Disconnect the VRO sensor from the engine harness and retest. If the engine performs correctly, replace the VRO or sensor.

### **ENGINE DIES WHEN QUICK-START DROPS OUT:**

Check ignition timing at idle with the White/Black temperature wire disconnected. Remember to allow for the 12-15 degree drop in ignition timing when Quick-Start disengages. Verify ignition timing after engine has warmed up, according to the service manual.

### **ENGINE STAYS IN QUICK-START:**

1. With the engine idling, check the Yellow/Red wire for DC voltage. If there is DC voltage over 2 volts on this wire while the engine is running, the Quick-Start will not disengage. A voltage of 5 to 7 volts will not engage the starter solenoid, yet will engage Quick-Start.
2. Short the White/Black temperature switch wire FROM the power pack to engine ground. Start the engine, if the Quick-Start drops out after approximately 5-10 seconds; replace the White/Black temperature switch.
3. Disconnect the Black/White wire from the power pack to the timerbase. If the Quick-Start feature is not now working, replace the power pack.

### **ENGINE WILL NOT ENGAGE QUICK-START:**

1. Disconnect the White/Black wire from the temperature sensor.
2. With the engine idling, check the Black/White timer base wire for DVA voltage. There should be about 6 to 10 volts DVA voltage on this wire while the engine is running for the Quick-Start to engage. If the voltage is not present at cranking, check the Orange to Orange/Black power coil wires for the 10-22V DVA. If the DVA on the Orange to Orange/Black power coil wires is correct, replace the power pack.
3. Short the White/Black temperature switch wire FROM the power pack to engine ground. If the voltage on the Black/White wire drops out after approximately 5 seconds but the engine timing does not change, replace the timer base. If the voltage remains present, disconnect the Yellow/Red wire to the pack and repeat the test. If the voltage still remains, replace the pack.

### **ENGINE TIMING TOO HIGH:**

1. Check the flywheel center hub magnet to make sure it's tight. Look for signs of cracks and bulges in the Brown ferret magnet material.
2. Short the White/Black temp wire to engine ground and see if the timing drops back to normal.
3. Check the DVA voltage on the Black/White wire going to the timer base. With the White/Black temp wire disconnected, the voltage should be 6 to 10 volts. When the White/Black temp wire is shorted to engine ground, the voltage should drop out. If the voltage on the Black/White wire stays in the 6-10 volt range, disconnect the Yellow/Red wire from the power pack. The voltage should drop out on the Black/White wire. If it does, the harness or starter solenoid is likely defective. If the voltage on the Black/White wire stays in the 6-10 volt range with the Yellow/Red wire disconnected and the White/Black wire shorted to engine ground, the power pack is defective.

### **ENGINE IDLING TOO HIGH:**

1. Index the flywheel for ALL cylinders. Check ignition timing on all cylinders. If one or more cylinders have advanced timing, replace the timerbase.
2. If the ignition timing on all cylinders is too high, check the flywheel center hub magnet to make sure it's tight. Look for signs of cracks and bulges in the Brown ferrete magnet.

# Johnson/Evinrude Troubleshooting

## Six Cylinder Engines (1988-2001 185-250 HP Quick-Start Models)

Service Note: Please use the Factory recommended spark plug (currently Champion QL77JC4) gapped at 0.030". (Note) These engines usually have a 35 Amp battery charging capacity. Due to the size and weight of the flywheel magnets, it is highly recommended that you check to make sure both the triggering and charge magnets are still secure in the flywheel before you service the engine. A loose or broken magnet can be deadly to you or your pocketbook. It is a recommended you index the flywheel and check the timing on all cylinders when servicing these engines. Also check for static firing and intermittent spark.

### NO SPARK ON ANY CYLINDER:

1. Disconnect BOTH of the Black/Yellow stop wires AT THE POWER PACK and retest. If the engine's ignition has spark, the stop circuit has a fault. Check the key switch, harness and shift switch.
2. Disconnect the Yellow wires from the stator to the rectifier and retest. If the engine sparks, replace the rectifier.
3. Check the cranking RPM. A cranking speed of less than 250-RPM will not allow the system to spark properly. This is usually caused by a weak battery or dragging starter. Connect a battery charger on its highest setting to the battery and retest. If good spark, replace the starter and/or battery with an 850+ CCA cranking/dual purpose non-maintenance-free type.
4. Inspect and clean all engine and ignition ground connections.
5. Check the stator and timer base resistance and DVA output as given below for BOTH banks:

| WIRE        | READ TO                     | RESISTANCE | DVA (Connected) | DVA (Disconnected) |
|-------------|-----------------------------|------------|-----------------|--------------------|
| Brown       | Brown/Yellow (1st Pair) (d) | 900-1100   | 150-400 V       | 150-400 V (*)      |
| Brown/White | Brown/Black (2nd Pair) (d)  | 900-1100   | 150-400 V       | 150-400 V (*)      |
| Orange      | Orange/Black                | 93-103     | 11-22 V         | 45-120 V (*)       |
| White       | Purple                      | (c)        | 100-400 V (a)   | 0.6 V + (#)        |
| White       | Blue                        | (c)        | 100-400 V (a)   | 0.6 V + (#)        |
| White       | Green                       | (c)        | 100-400 V (a)   | 0.6 V + (#)        |
| White       | Purple (2nd connector)      | (c)        | 100-400 V (a)   | 0.6 V + (#)        |
| White       | Blue (2nd connector)        | (c)        | 100-400 V (a)   | 0.6 V + (#)        |
| White       | Green (2nd connector)       | (c)        | 100-400 V (a)   | 0.6 V + (#)        |
| White       | Black/White (2nd connector) | 215-230    | 6-10 V (b)      | 6-10 V (from pack) |

(\*) This reading can be used to determine if a stator or pack has a problem. For instance, if you have no spark on any cylinder and the stator's DVA reading is out of spec – disconnect the stator wires and recheck the DVA output. If the reading is still out of spec – the stator is bad. If the reading is now within spec – the pack is bad.

(#) This reading can be used to determine if a pack has a problem in the triggering circuit. For instance, if you have no spark on one cylinder and the timer base's DVA reading for that cylinder is low – disconnect the timer base wires and recheck the DVA output. If the reading stays low – the timer base is bad. If the reading is now within spec – the pack is bad.

(a) Check stator DVA first. Then if timer base DVA is 0.6 - 2.5 V, the pack is faulty. If below 0.6 V, the timer base is faulty.

(b) DVA will drop below 1 V when the engine drops out of Quick-Start (engine is over 104 Degrees or 1200 RPM).

(c) Use a comparison reading as different brands of meters will give different readings. The typical range is 1M to 5M ohms. As long as you have approximately the same ohm reading on all six tests and the correct output with the DVA meter, the timer base should be good. Remember that temperature will affect the readings. The exception would be if one of the SCR's inside the timer base is breaking down while the engine is running. This can be found indexing the flywheel and checking the timing on all cylinders. If the readings are off, reverse the meter leads and retest to see if the readings are corrected.

6. Check the triggering and charge coil flywheel magnets for cracked, broken and loose magnets.

### NO SPARK OR INTERMITTENT SPARK ON ONE BANK:

1. Disconnect BOTH of the Black/Yellow stop wires AT THE POWER PACK and retest. If the engine's ignition now has spark, the stop circuit has a fault. Check the key switch, harness and shift switch.
2. Swap the stator wire pairs from one side of the engine to the other side and see if the problem moves. If it does, the stator is bad.
3. Disconnect the Yellow wires from the stator to the rectifier and retest. If the engine sparks, replace the rectifier.
4. Check the cranking RPM. A cranking speed of less than 250-RPM will not allow the system to spark properly.

## Johnson/Evinrude Troubleshooting

This is usually caused by a weak battery or dragging starter. Connect a battery charger on its highest setting to the battery and retest. If good spark, replace the starter and/or battery with an 850+ CCA cranking/dual purpose non-maintenance-free type.

5. Check the stator resistance and DVA output for BOTH banks (see NO SPARK ON ANY CYLINDER above).
6. Check the DVA output on the Orange wires from the power pack while connected to the ignition coils. You should have a reading of at least 150V or more. If the reading is low on one bank, disconnect the Orange wires from the ignition coil for that bank and reconnect them to a load resistor. Retest. If the reading is now good, one or all of the ignition coils are likely bad. A continued low reading indicates a bad power pack.

### NO SPARK OR INTERMITTENT SPARK ON ONE OR MORE CYLINDERS:

1. Check the cranking RPM. A cranking speed of less than 250-RPM will not allow the system to spark properly. This is usually caused by a weak battery or dragging starter. Connect a battery charger on its highest setting to the battery and retest. If good spark, replace the starter and/or battery with an 850+ CCA cranking/dual purpose non-maintenance-free type.
2. Check the timer base resistance and DVA output (see NO SPARK ON ANY CYLINDER above).
3. Check the DVA output on the Orange wires from the power pack while connected to the ignition coils. You should have a reading of at least 150V or more. If the reading is low on one cylinder, disconnect the Orange wire from the ignition coil for that cylinder and reconnect it to a load resistor. Retest. If the reading is now good, the ignition coil is likely bad. A continued low reading indicates a bad power pack or timer base.

4. Check the power pack resistance given below:

| Wire Color ( CYL) | Check to Wire Color                               | Resistance                |
|-------------------|---|---------------------------|
| Orange/Blue (#1)  | Blue (in 4 pin connector with Black/White wire)   | 110 (a)                   |
| Orange (#3)       | Purple (in 4 pin connector with Black/White wire) | 110 (a)                   |
| Orange/Green (#5) | Green (in 4 pin connector with Black/White wire)  | 110 (a)                   |
| Orange/Blue (#2)  | Blue (in 4 pin connector with White wire)         | 110 (a)                   |
| Orange (#4)       | Purple (in 4 pin connector with White wire)       | 110 (a)                   |
| Orange/Green (#6) | Green (in 4 pin connector with White wire)        | 110 (a)                   |
| White             | Black (Engine Ground)                             | Shorted (while connected) |
| Brown             | Black (Engine Ground)                             | Open or M range           |
| Brown/Yellow      | Black (Engine Ground)                             | Open or M range           |
| Brown/White       | Black (Engine Ground)                             | Open or M range           |
| Brown/Black       | Black (Engine Ground)                             | Open or M range           |

- (b) Use a comparison reading as different brands of meters will give different readings. The typical range is 90 to 150 ohms for the Orange wires. You should have approximately the same ohm reading on all six tests with the Orange wires. If one of the SCR's inside the power pack is shorted or open, the readings will be quite a bit different.

5. Check the spark plug wires for breaks and abrasions.
6. Visually inspect the ignition coils for burned or discolored areas and cracks in the casing (indicating arcing inside the coil).
7. Swap the ignition coil with one that is sparking correctly.
8. Rare causes include a weak trigger magnet. If possible, try another flywheel.

### POWER PACK OR TIMER BASE REPEATEDLY BLOWS ON SAME CYLINDER:

1. Check the timer base wires for shorts to engine ground as a shorted timer base wire can destroy a SCR inside the power pack.
2. In contrast, a shorted SCR inside the power pack can destroy a timer base coil. Check the timer base resistance and DVA output (see NO SPARK ON ANY CYLINDER above).
3. Replace the ignition coil on the cylinder dropping spark.

### ENGINE WILL NOT SHUT OFF:

Disconnect the stop wires at the power pack. Connect a jumper wire to the stop wires from the pack and short it to engine ground. If this stops the pack from sparking, the stop circuit has a fault. Check the key switch, harness and shift switch. If this does not stop the pack from sparking, replace the power pack.

### MISS AT ANY RPM:

1. Disconnect the Yellow wires from the stator to the rectifier and retest. If the miss clears, replace the rectifier.
2. In the water or on a Dynameters, check the DVA output on the Orange wires from the power pack while



## **Johnson/Evinrude Troubleshooting**

connected to the ignition coils. You should have a reading of at least 150V DVA or more, increasing with engine RPM until it reaches 300-400V DVA maximum. A sharp drop in DVA right before the miss becomes apparent on all cylinders will normally be caused by a bad stator. A sharp drop in DVA on less than all cylinders will normally be the power pack or timer base.

3. Connect an inductive tachometer to each cylinder in turn and try to isolate the problem. A high variance in RPM on one cylinder usually indicates a problem in the power pack or ignition coil. Occasionally a timer base will cause this same problem. Check the timer base DVA voltage (see NO SPARK ON ANY CYLINDER above).
4. Perform a high-speed shutdown and read the spark plugs. Check for water. A crack in the block can cause a miss at high speed when the water pressure gets high, but a normal shutdown will mask the problem.
5. Check the triggering and charge coil flywheel magnets for cracked, broken and loose magnets.

### **ENGINE WILL NOT ACCELERATE BEYOND 2500 RPM (Runs smooth below that RPM):**

1. Use a temperature probe and verify that the engine is not overheating.
2. Disconnect the tan temperature wire from the pack and retest. If the engine now performs properly, test and replace the defective temperature switch.
3. Disconnect the VRO sensor from the engine harness and retest. If the engine performs correctly, replace the VRO or sensor.
4. Make sure the tan temperature switch wire is not located next to a spark plug wire, as RF can trip slow without the warning horn sounding.
5. Check the diode in the engine harness's Tan wire between the Tan wire to the Temperature switch and the Tan wire to the remote oil tank. If shorted, replace with a 3 amp, 800V (or higher).

### **ENGINE DIES WHEN QUICK-START DROPS OUT:**

Disconnect the White/Black temperature wire and check ignition timing at idle. It should be about 10-12 degrees BTDC while in QuickStart. Timing will drop to 4-6 degrees ATDC when the White/Black is shorted to ground.

### **ENGINE STAYS IN QUICK-START:**

1. With the engine idling, check the Yellow/Red wire for DC voltage. If there is DC voltage over 2 volts on this wire while the engine is running, the Quick-Start will not disengage. A voltage of 5 to 7 volts will not engage the starter solenoid, yet will engage Quick-Start.
2. Short the White/Black temperature switch wire FROM the power pack to engine ground. Start the engine, if the Quick-Start drops out after approximately 5 seconds; replace the White/Black temperature switch.
3. Disconnect the Black/White wire from the power pack. If the Quick-Start feature is not now working, replace the power pack.

### **ENGINE WILL NOT ENGAGE QUICK-START:**

1. Disconnect the White/Black wire from the temperature sensor.
2. With the engine idling, check the Black/White timer base wire for DC voltage. There should be about 6 to 10 volts DC voltage on this wire while the engine is running for the Quick-Start to engage.
3. Short the White/Black temperature switch wire FROM the power pack to engine ground. If the voltage on the Black/White wire drops out after approximately 5 seconds but the engine timing does not change, replace the timer base. If the voltage remains present, disconnect the Yellow/Red wire to the pack and repeat the test. If the voltage still remains, replace the pack.

### **ENGINE TIMING TOO HIGH:**

1. Check the flywheel center hub magnet to make sure it's tight. Look for signs of cracks and bulges in the Brown ferret magnet material.
2. Short the White/Black temp wire to engine ground and see if the timing drops back to normal.
3. Check the DVA voltage on the Black/White wire going to the timer base. With the White/Black temp wire disconnected, the DVA voltage should be 6 to 10 volts. When the White/Black temp wire is shorted to engine ground, the voltage should drop out. If the voltage on the Black/White wire stays in the 6-10 volt range, disconnect the Yellow/Red wire from the power pack. The voltage should drop out on the Black/White wire. If it does, the harness or starter solenoid is likely defective. If the voltage on the Black/White wire stays in the 6-10 volt range with the Yellow/Red wire disconnected and the White/Black wire shorted to engine ground, the power pack is defective.



## Johnson/Evinrude Troubleshooting

### ENGINE IDLING TOO HIGH:

1. Index the flywheel for ALL cylinders. Check ignition timing on all cylinders. If one or more cylinders have advanced timing, replace the timerbase.
2. If the ignition timing on all cylinders is too high, check the flywheel center hub magnet to make sure it's tight. Look for signs of cracks and bulges in the Brown ferret magnet.

### ***Eight Cylinder Engines***

#### **1988-1998-250-300 HP Quick-Start Models**

(Note) These engines usually have a 35 Amp battery charging capacity. Due to the size and weight of the flywheel magnets, it is highly recommended that you check to make sure both the triggering and charge magnets are still secure in the flywheel before you service the engine. A loose or broken magnet can be deadly to you or your pocketbook. It is a recommended you index the flywheel and check the timing on all cylinders when servicing these engines. Also check for static firing and intermittent spark.

### NO SPARK ON ANY CYLINDER:

1. Disconnect BOTH of the Black/Yellow stop wires AT THE POWER PACK(S) and retest. If the engine's ignition has spark, the stop circuit has a fault. Check the key switch, harness and shift switch.
2. Disconnect the Yellow wires from the stator to the rectifier and retest. If the engine sparks, replace the rectifier.
3. Check the cranking RPM. A cranking speed of less than 250-RPM will not allow the system to spark properly. This is usually caused by a weak battery or dragging starter. Connect a battery charger on its highest setting to the battery and retest. If good spark, replace the starter and/or battery with an 850+ CCA cranking/dual purpose non-maintenance-free type.
4. Inspect and clean all engine and ignition ground connections.
5. Check the stator and timer base resistance and DVA output as given below for BOTH banks:

| WIRE   | READ TO                                 | RESISTANCE        | DVA (Connected) | DVA (Disconnected) |
|--------|---|-------------------|-----------------|--------------------|
| Brown  | Brown/Yellow                            | 900-1100 (35 amp) | 150-400 V       | 150-400 V (*)      |
| Orange | Orange/Black                            | 93-103            | 11-22 V         | 45-120 V (*)       |
| White  | Purple                                  | ⊙                 | 100-400 V (a)   | 0.6 V + (#)        |
| White  | Blue                                    | ⊙                 | 100-400 V (a)   | 0.6 V + (#)        |
| White  | Green                                   | ⊙                 | 100-400 V (a)   | 0.6 V + (#)        |
| White  | Pink                                    | ⊙                 | 100-400 V (a)   | 0.6 V + (#)        |
| White  | Purple (2 <sup>nd</sup> connector)      | ⊙                 | 100-400 V (a)   | 0.6 V + (#)        |
| White  | Blue (2 <sup>nd</sup> connector)        | ⊙                 | 100-400 V (a)   | 0.6 V + (#)        |
| White  | Green (2 <sup>nd</sup> connector)       | ⊙                 | 100-400 V (a)   | 0.6 V + (#)        |
| White  | Pink (2 <sup>nd</sup> connector)        | ⊙                 | 100-400 V (a)   | 0.6 V + (#)        |
| White  | Black/White (2 <sup>nd</sup> connector) | 215-225           | 6-10 V (b)      | 6-10 V (from pack) |

(\*) This reading can be used to determine if a stator or pack has a problem. For instance, if you have no spark on any cylinder and the stator's DVA reading is out of spec – disconnect the stator wires and recheck the DVA output. If the reading is still out of spec – the stator is bad. If the reading is now within spec – the pack is bad.

(#) This reading can be used to determine if a pack has a problem in the triggering circuit. For instance, if you have no spark on one cylinder and the timer base's DVA reading for that cylinder is low – disconnect the timer base wires and recheck the DVA output. If the reading stays low – the timer base is bad. If the reading is now within spec – the pack is bad.

(a) Check stator DVA first. Then if timer base DVA is 0.6 – 2.5 V, the pack is faulty. If below 0.6 V, the timer base is faulty.

(b) DVA will drop below 1 V when the engine drops out of Quick-Start (engine is over 104 Degrees or 1200 RPM).

⊙ Use a comparison reading as different brands of meters will give different readings. The typical range is 1M to 5M ohms. As long as you have approximately the same ohm reading on all six tests and the correct output with the DVA meter, the timer base should be good. Remember that temperature will affect the readings. The exception would be if one of the SCR's inside the timer base is breaking down while the engine is running. This can be found indexing the flywheel and checking the timing on all cylinders. If the readings are off, reverse the meter leads and retest to see if the readings are corrected.

6. Check the triggering and charge coil flywheel magnets for cracked, broken and loose magnets.

## **Johnson/Evinrude Troubleshooting**

### **NO SPARK OR INTERMITTENT SPARK ON ONE BANK or CYLINDERS 1-4 or 5-8:**

1. Disconnect BOTH of the Black/Yellow stop wires AT THE POWER PACK(S) and retest. If the engine's ignition has spark, the stop circuit has a fault. Check the key switch, harness and shift switch.
2. Swap the stator wire pairs from one side of the engine to the other side and see if the problem moves. If it does, the stator is bad.
3. Disconnect the Yellow wires from the stator to the rectifier and retest. If the engine sparks, replace the rectifier.
4. Check the cranking RPM. A cranking speed of less than 250-RPM will not allow the system to spark properly. This is usually caused by a weak battery or dragging starter. Connect a battery charger on its highest setting to the battery and retest. If good spark, replace the starter and/or battery with an 850+ CCA cranking/dual purpose non-maintenance-free type.
5. Check the stator and timer base resistance and DVA output on BOTH banks (see NO SPARK ON ANY CYLINDER above).
6. Check the DVA output on the Orange wires from the power pack while connected to the ignition coils. You should have a reading of at least 150V or more. If the reading is low on one bank, disconnect the Orange wires from the ignition coil for that bank and reconnect them to a load resistor. Retest. If the reading is now good, one or all of the ignition coils are likely bad. A continued low reading indicates a bad power pack.

### **NO SPARK OR INTERMITTENT SPARK ON ONE OR MORE CYLINDERS:**

1. Check the cranking RPM. A cranking speed of less than 250-RPM will not allow the system to spark properly. This is usually caused by a weak battery or dragging starter. Connect a battery charger on its highest setting to the battery and retest. If good spark, replace the starter and/or battery with an 850+ CCA cranking/dual purpose non-maintenance-free type.
2. Check the timer base resistance and DVA output (see NO SPARK ON ANY CYLINDER above).
3. Check the DVA output on the Orange wires from the power pack while connected to the ignition coils. You should have a reading of at least 150V or more. If the reading is low on one cylinder, disconnect the Orange wire from the ignition coil for that cylinder and reconnect it to a load resistor. Retest. If the reading is now good, the ignition coil is likely bad. A continued low reading indicates a bad power pack or timer base.
4. Check the power pack resistance given below:

| Wire Color           | (CYL) | Check to Wire Color                               | Resistance      |
|----------------------|-------|---|-----------------|
| Orange/Blue          | (#1)  | Blue (in 5 pin connector with White wire)         | 110 (a)         |
| Orange/Green         | (#3)  | Green (in 5 pin connector with White wire)        | 110 (a)         |
| Orange/Blue/White    | (#5)  | Blue (in 5 pin connector with Black/White wire)   | 110 (a)         |
| Orange/Green/White   | (#7)  | Green (in 5 pin connector with Black/White wire)  | 110 (a)         |
| Orange/Purple        | (#2)  | Purple (in 5 pin connector with White wire)       | 110 (a)         |
| Orange/Pink (or Red) | (#4)  | Pink (in 5 pin connector with White wire)         | 110 (a)         |
| Orange/Purple/White  | (#6)  | Purple (in 5 pin connector with Black/White wire) | 110 (a)         |
| Orange /Pink/White   | (#8)  | Pink (in 5 pin connector with Black/White wire)   | 110 (a)         |
| White                |       | Black (Engine Ground)                             | Shorted         |
| Brown                |       | Black (Engine Ground)                             | Open or M range |
| Brown/Yellow         |       | Black (Engine Ground)                             | Open or M range |
| Brown/White          |       | Black (Engine Ground)                             | Open or M range |
| Brown/Black          |       | Black (Engine Ground)                             | Open or M range |

(a) Use a comparison reading as different brands of meters will give different readings. The typical range is 90 to 150 ohms for the Orange wires. You should have approximately the same ohm reading on all six tests with the Orange wires. If one of the SCR's inside the power pack is shorted or open, the readings will be quite a bit different.

5. Check the spark plug wires for breaks and abrasions.
6. Visually inspect the ignition coils for burned or discolored areas and cracks in the casing (indicating arcing inside the coil).
7. Swap the ignition coil with one that is sparking correctly.
8. Rare causes include a weak trigger magnet. If possible, try another flywheel.

### **POWER PACK OR TIMER BASE REPEATEDLY BLOWS ON SAME CYLINDER:**

1. Check the timer base wires for shorts to engine ground as a shorted timer base wire can destroy a SCR inside the power pack.
2. In contrast, a shorted SCR inside the power pack can destroy a timer base coil. Check the timer base resistance and DVA output (see NO SPARK ON ANY CYLINDER).

## **Johnson/Evinrude Troubleshooting**

3. Replace the ignition coil on the cylinder dropping spark.

### **ENGINE WILL NOT SHUT OFF:**

Disconnect the stop wires at the power pack. Connect a jumper wire to the stop wires from the pack and short it to engine ground. If this stops the pack from sparking, the stop circuit has a fault. Check the key switch, harness and shift switch. If this does not stop the pack from sparking, replace the power pack. Repeat test as necessary for additional packs.

### **MISS AT ANY RPM:**

1. Disconnect the Yellow wires from the stator to the rectifier and retest. If the miss clears, replace the rectifier.
2. In the water or on a Dynameters, check the DVA output on the Orange wires from the power pack while connected to the ignition coils. You should have a reading of at least 150V DVA or more, increasing with engine RPM until it reaches 300-400V DVA maximum. A sharp drop in DVA right before the miss becomes apparent on all cylinders will normally be caused by a bad stator. A sharp drop in DVA on less than all cylinders will normally be the power pack or timer base.
3. Connect an inductive tachometer to each cylinder in turn and try to isolate the problem. A high variance in RPM on one cylinder usually indicates a problem in the power pack or ignition coil. Occasionally a timer base will cause this same problem. Check the timer base DVA voltage (see NO SPARK ON ANY CYLINDER above).
4. Perform a high-speed shutdown and read the spark plugs. Check for water. A crack in the block can cause a miss at high speed when the water pressure gets high, but a normal shutdown will mask the problem.
5. Check the triggering and charge coil flywheel magnets for cracked, broken and loose magnets.

### **ENGINE WILL NOT ACCELERATE BEYOND 2500 RPM (Runs smooth below that RPM):**

1. Use a temperature probe and verify that the engine is not overheating.
2. Disconnect the tan temperature wire from the pack and retest. If the engine now performs properly, test and replace the defective temperature switch, VRO, engine harness or boat harness.
3. Make sure the tan temperature switch wire is not located next to a spark plug wire.
4. Disconnect the VRO sensor from the engine harness and retest. If the engine performs correctly, replace the VRO or sensor.

### **ENGINE STAYS IN QUICK-START:**

1. With the engine idling, check the Yellow/Red wire for DC voltage. If there is DC voltage on this wire while the engine is running, the Quick-Start will not disengage. A voltage of less than 7 volts will not engage the starter solenoid, yet will engage Quick-Start.
2. Short the White/Black temperature switch wire FROM the power pack to engine ground. Start the engine, if the Quick-Start drops out after approximately 5 seconds, replace the White/Black temperature switch.
3. Disconnect the Black/White wire from the power pack. If the Quick-Start feature is not now working, replace the power pack.

### **ENGINE DIES WHEN QUICK-START DROPS OUT:**

Check ignition timing at idle with the White/Black temperature wire disconnected. Remember to allow for the drop in ignition timing when Quick-Start disengages. Verify ignition timing after engine has warmed up, according to the service manual.

### **ENGINE WILL NOT ENGAGE QUICK-START:**

1. Disconnect the White/Black wire from the temperature sensor.
2. With the engine idling, check the Black/White timer base wire for DC voltage. There should be about 6 to 10 volts DC voltage on this wire while the engine is running for the Quick-Start to engage.
3. Short the White/Black temperature switch wire FROM the power pack to engine ground. If the voltage on the Black/White wire drops out after approximately 5 seconds but the engine timing does not change, replace the timer base. If the voltage remains present, disconnect the Yellow/Red wire to the pack and repeat the test. If the voltage still remains, replace the pack.

### **ENGINE TIMING TOO HIGH:**

1. Check the flywheel center hub magnet to make sure it's tight. Look for signs of cracks and bulges in the Brown ferrite magnet material.

## **Johnson/Evinrude Troubleshooting**

2. Short the White/Black temp wire to engine ground and see if the timing drops back to normal.
3. Check the DC voltage on the Black/White wire going to the timer base. With the White/Black temp wire disconnected, the voltage should be 6 to 10 volts. When the White/Black temp wire is shorted to engine ground, the voltage should drop out. If the voltage on the Black/White wire stays in the 6-10 volt range, disconnect the Yellow/Red wire from the power pack. The voltage should drop out on the Black/White wire. If it does, the harness or starter solenoid is likely defective. If the voltage on the Black/White wire stays in the 6-10 volt range with the Yellow/Red wire disconnected and the White/Black wire shorted to engine ground, the power pack is defective.

### **ENGINE IDLING TOO HIGH:**

1. Index the flywheel for ALL cylinders. Check ignition timing on all cylinders. If one or more cylinders have advanced timing, replace the timerbase.
2. If the ignition timing on all cylinders is too high, check the flywheel center hub magnet to make sure it's tight. Look for signs of cracks and bulges in the Brown ferret magnet.

### **Johnson/Evinrude 60° 3 Cylinder Optical Ignition (OIS 2000) Carbureted 1996-2001 Model Years**

Due to the differences in this ignition system, troubleshooting can be somewhat difficult if you are not familiar with the design. The other Johnson/Evinrude Quick-Start ignitions use stator charge coils and a power coil to provide high voltage and power for the Quick-Start and rev limiter circuits. They require a sensor for triggering and use separate magnets for the high voltage and triggering the sensor. The OIS 2000 Optical system uses the stator charge coil to provide high voltage for the firing of the ignition coils and a power coil to provide power for the electronics, both inside the power pack and sensor. The other Quick-Start models will run the engine without the power coil being connected (of course this will burn out the control circuits inside the power pack). The OIS 2000 ignition has to have the power coil supplying power in order to operate the Quick-Start, S.L.O.W., rev limiter, and provide the firing pulse to the coils. The optical sensor located below the flywheel is fed power from the power pack and sends crankshaft position, cylinder location and direction of rotation back to the power pack. The pack is smart enough to know not to spark if the engine is not turning in the right direction. S.L.O.W. functions reduce the engine RPM to approximately 2500 when the engine over-heats or the no oil warning is activated. Quick-Start (a 10° timing advance) activates as long as the engine RPM is below 1100 and the engine temperature is below 105° F. Quick-Start will also activate for 5-10 seconds each time the engine is started regardless of engine temperature. There are a couple of critical items you should be aware of on these engines. First, the spark plug wires have to be the Gray inductive wires – these are NOT automotive wires. Secondly, the spark plugs have to be the factory recommended QL86C or QL87YC. Use of other spark plugs or wires can cause problems inside the power pack from RFI and MFI noise.

Ignition Timing AFTER the engine drops out of QuickStart for Idle is 4 Degrees ATDC. WOT Timing is 19-21 BTDC for the 25 HP and 21-23 Degrees BTDC for the 35 HP.

### **NO FIRE ON ANY CYLINDER:**

1. Disconnect the Port 4 pin connector with the Black/Yellow stop wire FROM THE POWER PACK and retest. If the engine's ignition now has fire, the stop circuit has a fault. Check the key switch and harness.
2. On electric start models, disconnect the Yellow wires from the stator to the rectifier and retest. If the engine now has fire, replace the rectifier.
3. Check the cranking RPM. A cranking speed of less than 250-RPM may not allow the system to spark properly. This can be caused by a weak battery, dragging starter, bad battery cables or a mechanical problem inside the engine.
4. Verify the engine is turning in a clockwise direction. If not, see TRIES TO RUN BACKWARDS below.
5. Check the power pack and ignition coil ground wires for corrosion and tightness.
6. Connect a spark gap tester to all cylinders.
7. On remote electric start models, disconnect the boat side harness and connect a remote starter unit. Check for fire. If the engine has fire, check the boat side harness's Black/Yellow wire for shorts to ground.
8. Remove the flywheel and check the sensor wheel for damage, especially where the top slots are located. Sometimes the wheels will break out where the windows overlap.
9. Check the sensor eyes for dirt, grease, etc. If you have to clean it, use denatured alcohol and a Q-tip. Do not use any other cleaning agent because damage to the optical lens will occur.
10. Check the stator resistance and DVA voltage as given below:



## Johnson/Evinrude Troubleshooting

| WIRE   | READ TO      | RESISTANCE | DVA (Connected) | DVA (Disconnected) |
|--------|--------------|------------|-----------------|--------------------|
| Brown  | Brown/Yellow | 720-880    | 150-400 V       | 300 V Min (*)      |
| Orange | Orange/Black | 52-62      | 11-22 V         | 100 V Min (*)      |

(\*) This reading can be used to determine if a stator or pack has a problem. For instance, if you have no spark on any cylinder and the stator's DVA reading is out of spec – disconnect the stator wires and recheck the DVA output. If the reading is still out of spec – the stator is bad. If the reading is now within spec – the pack is bad.

(NOTE) Low readings on all checks indicate a possible problem with the flywheel magnets that require checking.

(SERVICE NOTE) It is recommended that liquid neoprene be applied to the areas where piercing probes were used.

11. Check the DVA output from the power pack to the primary coil wires as follows:

| WIRE          | READ TO       | DVA (Connected) |
|---------------|---------------|-----------------|
| Orange/Blue   | Engine Ground | 150 V +         |
| Orange/Purple | Engine Ground | 150 V +         |
| Orange/Green  | Engine Ground | 150 V +         |

(NOTE) If the DVA values are below these specifications, the power pack or sensor is likely bad.

12. Check the sensor DC voltage as follows:

| WIRE         | READ TO       | DC Voltage (Connected) |
|--------------|---------------|------------------------|
| Orange/Red   | Engine Ground | 10.5-12 VDC            |
| Black/Orange | Engine Ground | 8-10 VDC               |

(WARNING!!) The Black/Orange wire should NEVER be shorted to engine ground as this will damage the sensor.

13. Check the charge coil flywheel magnets for cracked, broken and loose magnets.

ONLY HAS FIRE AS LONG AS THE KEY SWITCH IS ENGAGED OR WILL NOT REV ABOVE IDLE SPEED:

Check the DVA voltage on the stator's power coil (Orange to Orange/Black) as given above in Step #13:

(NOTE) The readings should rapidly increase as the engine RPM increases and stabilize below 22 volts DVA (voltage exceeding 22 V DVA indicates a defective power pack). A sharp drop in voltage right before the miss becomes apparent usually indicates a bad stator winding.

### TRIES TO RUN BACKWARDS:

1. Verify the ignition coil primary wires are on the correct coils. Orange/Blue goes to the top cylinder, Orange/Purple goes to the middle cylinder and the Orange/Green wire goes to the bottom cylinder.
2. Check the encoder wheel for physical damage.
3. Check the Idle timing. While in Quick-Start, it should be set to approximately 6° BTDC. After Quick-Start, it will be set to 4° ATDC.
4. Index the flywheel for all 3 cylinders. The timing should have the same off set from TDC for all cylinders. If the timing is off on one cylinder, replace the power pack.
5. Try another sensor.
6. Replace the power pack.

### NO FIRE ON ONE CYLINDER:

1. Check the ignition coil's primary and secondary windings.

| WIRE       | READ TO              | RESISTANCE        |
|------------|----------------------|-------------------|
| Ground Tab | Primary Coil Tower   | 0.28 ohms +/- 20% |
| Ground Tab | Secondary Coil Tower | 2000-2600 ohms    |

1. Swap the Orange wire for that cylinder with another cylinder and see if the problem moves. If so, replace the power pack.

## Johnson/Evinrude 60° 4 Cylinder Optical Ignition (OIS 2000)



## **Johnson/Evinrude Troubleshooting**

### **Carbureted 1995-2006 Model Years**

Due to the differences in this ignition system, troubleshooting can be somewhat difficult if you are not familiar with the design. The other Johnson/Evinrude Quick-Start ignitions use stator charge coils and a power coil to provide high voltage and power for the Quick-Start and rev limiter circuits. They require a sensor for triggering and use separate magnets for the high voltage and triggering the sensor. The OIS 2000 Optical system uses the stator charge coil to provide high voltage for the firing of the ignition coils and a power coil to provide power for the electronics, both inside the power pack and inside the sensor. The other Quick-Start models will run the engine without the power coil being connected (of course this will burn out the control circuits inside the power pack). The OIS 2000 ignition has to have the power coil supplying power in order to operate the Quick-Start, S.L.O.W., rev limiter, and spark the coils beyond cranking speed. The optical sensor located on the top is fed power from the power pack and sends crankshaft position, cylinder location and direction of rotation back to the power pack. The pack is smart enough to know not to spark if the engine is not turning in the right direction. S.L.O.W. functions reduce the engine RPM to approximately 2500 when the engine over-heats or the no oil warning is activated. Quick-Start (a 10° timing advance) activates as long as the engine RPM is below 1100, the engine temperature is below 105° F and the Yellow/Red wire from the starter solenoid is not feeding 12V DC to the power pack all of the time. Quick-Start will also activate for 5-10 seconds each time the engine is started regardless of engine temperature. CDI Electronics (Blue case with Red sleeve) power packs have a built-in feature to compensate for a shorted cold sensor, allowing the engine to come out of Quick-Start after 5 minutes of running time regardless of the condition of the cold sensor. The CDI power pack will not have consistent spark if the wrong encoder wheel (6 cylinder) is installed by mistake.

At cranking speed the voltage from the stator may not be enough to operate the circuits inside the power pack, therefore there is battery voltage supplied from the starter solenoid via the Yellow/Red striped wire. The extra voltage is needed in order for the optical sensor to operate correctly as low voltage from the battery and/or stator can cause intermittent spark or no spark at all. There are a couple of critical items you should be aware of on these engines. First, the spark plug wires have to be the Gray inductive resistor wires – these are NOT automotive wires. Secondly, the spark plugs have to be the factory recommended QL78YC. Use of other spark plugs or wires can cause problems inside the power pack from RFI and MFI noise. CDI Electronics wire set is P/N: 931-4922.

A breakthrough at CDI Electronics has allowed the use of microprocessor digital control circuits to handle the timing, Quick-Start, S.L.O.W. and rev limiter functions inside the power pack. This allows the timing to be set using a timing light, remote starter, spark gap tester, piston stop tool and a jumper wire. With these new digital power packs, you disconnect the port temperature switch/sensor leads and use a jumper wire to short the tan temperature sensor wire to engine ground. Once you have verified the timing pointer using a piston stop tool (Or a dial indicator), connect all spark plug wires to a spark gap tester, connect a remote starter to the engine and a timing light to # 1 spark plug wire. When you crank the engine over with the remote starter and check the timing, you should see the timing is set to approximately 4°-6° ATDC (After Top Dead Center). By advancing the throttle all the way and rechecking the timing for WOT (Wide Open Throttle), you should see approximately 19° - 21° BTDC (Before Top Dead Center) Without this timing feature built into the power pack, you would not be able to easily set the timing for idle or WOT without a optical diagnostic tool. Additional advantages offered by the digital circuitry include the ability to compensate for a bad temperature switch, a smoother rev limit, customized rev limiters and special timing curves.

#### **Additional items to be aware of:**

1. Originally the spark plugs were the QL82YC, but that recommendation was changed to the QL78YC for improved performance.
2. Some engines do not have the RFI/MFI noise shield between the ignition coils and the power pack. If it is missing, replace it.

#### **NO SPARK ON ANY CYLINDER:**

1. Disconnect the Black/Yellow stop wire AT THE POWER PACK and retest. If the engine's ignition has spark, the stop circuit has a fault. Check the key switch, harness and shift switch.
2. Disconnect the Yellow wires from the stator to the rectifier and retest. If the engine sparks, replace the rectifier.
3. Check the cranking RPM. A cranking speed of less than 250-RPM will not allow the system to spark properly. This can be caused by a weak battery, dragging starter, bad battery cables or a mechanical problem inside the engine.
4. Verify the engine is turning in a clockwise direction. If not, see TRIES TO RUN BACKWARDS below.
5. Check the power pack and ignition coil ground wires for corrosion and tightness.
6. Connect a spark gap tester to all cylinders.
7. Disconnect the boat side harness and connect a remote starter unit. Check for spark. If the engine has spark, check the boat side harness's Black/Yellow wire for shorts to ground.

## Johnson/Evinrude Troubleshooting

8. Disconnect the Port 4 pin connector (with the Yellow/Red, Black/Yellow, Tan and White/Black wires) from the power pack and see if spark returns. If it does spark, check resistance to see if the Black/Yellow wire is shorted to engine ground.
9. If it loses spark after the key switch is disengaged, check the DVA voltage on the stator's power coil (Orange to Orange/Black) as given below in Step #13. Either the power coil or power pack is the fault.
10. Check the battery voltage on the Yellow/Red wire while cranking the engine. If below 11 VDC, charge the battery and check all battery cables. A continued low battery reading could be from a dragging starter. If still below 11 VDC, disconnect the power pack's Yellow/Red wire from the starter solenoid and apply a verified 12 + VDC to the Yellow/Red wire. If the engine now runs good, check the DVA voltage on the stator's power coil (Orange to Orange/Black) as given below in Step #13. Either the power coil or power pack is the fault.
11. Remove the sensor wheel and check for damage, especially where the top slots are located. Sometimes the wheels will break out where the windows overlap.
12. Check the sensor eyes for dirt, grease, etc. If you have to clean it, use denatured alcohol and a Q-tip. Do not use any other cleaning agent because damage to the optical lens will occur.
13. Check the stator resistance and DVA voltage as given below:

| WIRE   | READ TO                       | RESISTANCE | DVA (Connected) | DVA (Disconnected) |
|--------|-------------------------------|------------|-----------------|--------------------|
| Brown  | Brown/Yellow (or Brown/White) | 900-1200   | 150-400 V       | 150-400 V (*)      |
| Orange | Orange/Black                  | 45-65      | 11-22 V         | 45-120 V (*)       |

(\*) This reading can be used to determine if a stator or pack has a problem. For instance, if you have no spark on any cylinder and the stator's DVA reading is out of spec – disconnect the stator wires and recheck the DVA output. If the reading is still out of spec – the stator is bad. If the reading is now within spec – the pack is bad.

(NOTE) Low readings on all checks indicate a possible problem with the flywheel magnets that require checking.

(SERVICE NOTE) It is recommended that liquid neoprene be applied to the areas where piercing probes were used.

14. Check the DVA output from the power pack to the primary coil wires as follows:

| WIRE         | READ TO       | DVA (Connected) |
|--------------|---------------|-----------------|
| Orange/Blue  | Engine Ground | 150 V +         |
| Orange/Green | Engine Ground | 150 V +         |

(NOTE) If the DVA values are below these specifications, the power pack or sensor is likely bad.

15. Check the sensor DC voltage as follows:

| WIRE         | READ TO       | DC voltage (Connected) |
|--------------|---------------|------------------------|
| Orange/Red   | Engine Ground | 10.5-12 VDC            |
| Black/Orange | Engine Ground | 8-10 VDC               |

(WARNING!!) The Black/Orange wire should NEVER be shorted to engine ground as this will damage the sensor.

16. Check the charge coil flywheel magnets for cracked, broken and loose magnets.

### ONLY HAS SPARK AS LONG AS THE KEY SWITCH IS ENGAGED OR WILL NOT REV ABOVE IDLE SPEED:

Check the DVA voltage on the stator's power coil (Orange to Orange/Black) as given above in Step #13:

(NOTE) The readings should rapidly increase as the engine RPM increases and stabilize below 22 volts DVA (voltage exceeding 22 V DVA indicates a bad power pack). A sharp drop in voltage right before the miss becomes apparent usually indicates a bad stator winding. A sharp drop in voltage when you disengage the key switch indicates a bad power coil on the stator.

### TRIES TO RUN BACKWARDS:

1. Check the encoder wheel. It must have 5 notches, not 7. Also, check for physical damage.
2. Check the timing. Before Quick-Start, it should be set to approximately 4° BTDC. After Quick-Start, it will be set to 6° ATDC.
3. Try another sensor.

## **Johnson/Evinrude Troubleshooting**

4. Replace the power pack.

### **NO SPARK OR INTERMITTENT SPARK ON ONE BANK:**

1. Disconnect the Yellow wires from the stator to the rectifier and retest. If the engine sparks, replace the rectifier.
2. Check the cranking RPM. A cranking speed of less than 250-RPM will not allow the system to spark properly. This can be caused by a weak battery, dragging starter, bad battery cables or a mechanical problem inside the engine.
3. Check the stator resistance and DVA output (see Step #13 on NO SPARK ON ANY CYLINDER above). If the power pack has no spark on one bank and the readings are good, replace the power pack.
4. Disconnect the 4-pin connector on the port side of the power pack and see if the spark returns. If it does, check resistance to see if the Black/Yellow wire is shorted to engine ground. Check to see if the Shift Interrupter switch is located in the circuit where there is no spark.

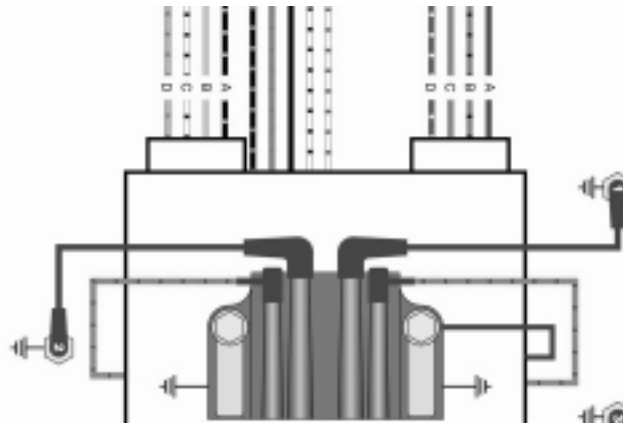

| Port 4 Pin Connector | Starboard 4 Pin Connector |  |
|----------------------|---------------------------|--|
| a) Black/Yellow      | a) Brown                  |  |
| b) Tan               | b) Orange/Black           |  |
| c) White/Black       | c) Orange                 |  |
| d) Yellow/Red        | d) Brown/Yellow           |  |

### **POWER PACK OR TIMER BASE REPEATEDLY BLOWS ON SAME CYLINDER:**

1. Check the sensor wires for shorts to engine ground as a shorted sensor wire can destroy a SCR inside the power pack.
2. In contrast, a shorted SCR inside the power pack can destroy a sensor coil. Check the sensor DVA output (see NO SPARK ON ANY CYLINDER above).
3. Replace the ignition coil on the cylinder dropping spark.

### **ENGINE WILL NOT SHUT OFF:**

Disconnect the stop wire at the power pack. Connect a jumper wire to the stop terminal in the pack and short it to engine ground. If this stops the pack from sparking, the stop circuit has a fault. Check the key switch, harness and shift switch. If this does not stop the pack from sparking, replace the power pack. Repeat test as necessary for additional packs.

### **ONLY SPARKS #1 CYLINDER:**

Check the optical sensor to encoder wheel mesh. You may need to shim the optical sensor upwards 25/1000" at a time to make it engage the encoder wheel.

### **MISS AT ANY RPM:**

1. Disconnect the Yellow wires from the stator to the rectifier and retest. If the miss clears, replace the rectifier.
2. In the water or on a Dynameters, check the DVA output on the Orange wires from the power pack while connected to the ignition coils. You should have a reading of at least 150V DVA or more, increasing with engine RPM until it reaches 300-400V DVA maximum. A sharp drop in DVA right before the miss becomes apparent on all cylinders will normally be caused by a bad stator. A sharp drop in DVA on less than all cylinders will normally be the power pack.
3. If the engine runs fine until you get above 4900 RPM and then starts missing, check the Orange to Orange/Black power coil wires with an oscilloscope (if available) or replace the pack. A breakdown inside the pack could cause RFI noise to activate the rev limiter for no apparent reason.

## **Johnson/Evinrude Troubleshooting**

4. Connect an inductive tachometer to the spark plug wires one at a time and compare the readings. If most of the cylinders show the same reading and one or two show different readings, check the primary wires with the inductive pickup to see if the readings are the same from the power pack. A difference in readings between the primary and secondary coil wires usually indicates a bad coil or bad ignition wires. No difference indicates a bad power pack.
5. Perform a high-speed shutdown and read the spark plugs. Check for water. A crack in the block can cause a miss at high speed when the water pressure gets high, but a normal shutdown will mask the problem.
6. Check the charge coil flywheel magnets for cracked, broken and loose magnets.

### **ENGINE WILL NOT REV ABOVE 2500 RPM AND SHAKES HARD (SLOW ACTIVATED):**

1. Verify the engine is not actually over-heating by using a digital pyrometer.
2. Check the routing of the tan temperature wires, an example of a bad location is shown below. The tan wires have to be located as far away as possible from the spark plug wires.
3. Verify the engine is not overheating and disconnect the Tan temperature sensor wire. If the engine performs normally, check both temperature sensors and replace the defective one.
4. If there is not any indication of a problem at this point, replace the power pack.

### **ENGINE STAYS IN QUICK-START:**

1. Check the Yellow/Red wire for DC volts while the engine is running. You should only see voltage on this wire while the starter solenoid is engaged. A DC voltage of 5-7 volts will not engage the starter solenoid, but will engage Quick-Start.
2. Short the White/Black temperature switch wire FROM the power pack to engine ground. Start the engine, if the Quick-Start drops out after approximately 5 seconds, replace the White/Black temperature switch.
3. Disconnect the Black/White wire from the power pack. If the Quick-Start feature is not now working, replace the power pack.

### **ENGINE DIES WHEN QUICK-START DROPS OUT:**

Check ignition timing at idle with the White/Black temperature wire disconnected. Remember to allow for the 10 degree advance in ignition timing while Quick-Start is engaged. Verify ignition timing after engine has warmed up and the White/Black wire is grounded, according to the service manual.

## **Johnson/Evinrude 60° 6 Cylinder Optical Ignition (OIS 2000) Carbureted 1991-2006 Model Years**

Due to the differences in this ignition system, troubleshooting can be somewhat difficult if you are not familiar with the design. The other Johnson/Evinrude Quick-Start ignitions use stator charge coils and a power coil to provide high voltage and power for the Quick-Start and rev limiter circuits. They require a sensor for triggering and use separate magnets for the high voltage and triggering the sensor.

The OIS 2000 Optical system uses the stator charge coils to provide high voltage for the firing of the ignition coils and a power coil to provide power for the electronics, both inside the power pack and inside the sensor. The other Quick-Start models will run the engine without the power coil being connected (of course this will burn out the control circuits inside the power pack). The OIS 2000 ignition has to have the power coil supplying power in order to operate the Quick-Start, S.L.O.W., rev limiter, and spark the coils beyond cranking speed.

The optical sensor located on the top is fed power from the power pack and sends crankshaft position, cylinder location and direction of rotation back to the power pack. The pack is smart enough to know not to spark if the engine is not turning in the right direction. S.L.O.W. functions reduce the engine RPM to approximately 2500 when the engine over-heats or the no oil warning is activated. Quick-Start (a 10° timing advance) activates as long as the engine RPM is below 1100, the engine temperature is below 105° F and the Yellow/Red wire from the starter solenoid is not feeding 12V DC to the power pack all of the time.



## **Johnson/Evinrude Troubleshooting**

Quick-Start will also activate for 5-10 seconds each time the engine is started regardless of engine temperature. CDI Electronics (Blue case with Red sleeve) power packs have a built-in feature to compensate for a shorted cold sensor, allowing the engine to exit Quick-Start after 5 minutes of running time regardless of the condition of the cold sensor. The CDI power pack also will not spark if the wrong encoder wheel (4 cylinder) is installed by mistake. At cranking speed the voltage from the stator may not be enough to operate the circuits inside the power pack. Therefore, battery voltage supplied via the Yellow/Red striped start wire.

The extra voltage is needed in order for the optical sensor to operate correctly as low voltage from the battery and/or stator can cause intermittent spark or no spark at all. There are a couple of critical items you should be aware of on these engines. First, the spark plug wires have to be the Gray inductive resistor wires – these are NOT automotive wires. Secondly, the spark plugs should be the factory recommended QL78YC. Use of other spark plugs or wires can cause problems inside the power pack from RFI and MFI noise. CDI Electronics has the spark plug wires available as a set, P/N: 931-4921.

A breakthrough at CDI Electronics has allowed the use of microprocessor digital control circuits to handle the timing, Quick-Start, S.L.O.W. and rev limiter functions inside the power pack. This allows the timing to be set using a timing light, remote starter, spark gap tester, piston stop tool and a jumper wire. With these new digital power packs, you disconnect the port temperature switch/sensor leads and use a jumper wire to short the tan temperature sensor wire to engine ground. Once you have verified the timing pointer using a piston stop tool (Or a dial indicator), connect all spark plug wires to a spark gap tester, connect a remote starter to the engine and a timing light to # 1 spark plug wire.

When you crank the engine over with the remote starter and check the timing, you should see the timing is set to approximately 4°-6° ATDC (After Top Dead Center). By advancing the throttle all the way and rechecking the timing for WOT (Wide Open Throttle), you should see approximately 19° - 20° BTDC (Before Top Dead Center) Without this timing feature built into the power pack, you will need the 511-4017 Timing Tool or the OEM version to set the timing for idle and WOT. Additional advantages offered by the digital circuitry include the ability to compensate for a bad temperature switch, a smoother rev limit, customized rev limiters and special timing curves.

### **Additional items to be aware of:**

1. 1991 and 1992 engines came out with a Black sleeved power pack (P/N 584122) and stator (P/N 584109) and used a P/N 584265 sensor. In 1993 the power packs were changed to a Gray sleeve (Production) power pack (P/N 584910). The stator was changed to a Gray sleeve (P/N 584981) and the sensor was changed to P/N 584914. Engines with ignition problems had a service replacement power pack with a Blue sleeve and a replacement sensor installed as a set. The Blue sleeved power pack was only available as a service replacement. The Gray sleeved stator could be used with all of the power packs, but the Black sleeved stator was to be used only with a Black sleeved power pack. The sensor P/N changed to 586343 in the late 1990's.
2. The Gray inductive spark plug wires replaced the Black copper spark plug wires that were used on the early 1990's engines.
3. Originally the spark plugs were the QL82YC, but that recommendation was changed to the QL78YC for improved performance.
4. Early 150 and 175 HP engines did not have the tension washer on top of the sensor encoder wheel. This washer is required to keep the encoder locked in place. If it is missing, be sure to install the correct washer.
5. 1991 and 1992 engines did not have a shift interrupter switch. This resulted in hard shifting and required a conversion to resolve this problem.
6. The shift interrupter switch stopped the spark on the starboard bank of cylinders from 1993 thru mid 1990's. By 1998, a change was made for the shift interrupter switch to stop the spark on the Port bank.
7. 1991 through late 1990's engines occasionally developed a crack in the water jacket allowing water into the intake at high speed. This typically resulted in # 1 cylinder ingesting water. You can usually see signs of this because the head looks like it has been steam cleaned inside the combustion chamber.
8. Some engines do not have the RFI/MFI noise shield between the ignition coils and the power pack. If it is missing, replace it.

### **NO FIRE ON ANY CYLINDER:**

1. Disconnect BOTH of the Black/Yellow stop wires AT THE POWER PACK and retest. If the engine's ignition has fire, the stop circuit has a fault. Check the key switch, harness and shift switch.
2. Disconnect the Yellow wires from the stator to the rectifier and retest. If the engine has fire, replace the rectifier.



## Johnson/Evinrude Troubleshooting

3. Check the cranking RPM. A cranking speed of less than 250-RPM will not allow the system to fire properly. This can be caused by a weak battery, dragging starter, bad battery cables or a mechanical problem inside the engine.
4. Verify the engine is turning in a clockwise direction. If not, see TRIES TO RUN BACKWARDS below.
5. Check the power pack and ignition coil ground wires for corrosion and tightness.
6. Connect a spark gap tester to all cylinders.
7. Disconnect the boat side harness and connect a remote starter unit. Check for fire. If the engine has fire, check the boat side harness's Black/Yellow wire for shorts to ground.
8. Disconnect the 5-pin connector on the port side of the power pack and see if fire returns. If it does fire, check resistance to see if the Black/Yellow wires are shorted to engine ground.
9. If it loses fire after the key switch is disengaged, check the DVA voltage on the stator's power coil (Orange to Orange/Black) as given below in Step #13. Either the power coil or power pack is the fault.
10. Check the battery voltage on the Yellow/Red wire while cranking the engine. If below 11 VDC, charge the battery and check all battery cables. A continued low battery reading could be from a dragging starter. If still below 11 VDC, disconnect the power pack's Yellow/Red wire from the starter solenoid and apply a verified 12 + VDC to the Yellow/Red wire. If the engine now runs good, check the DVA voltage on the stator's power coil (Orange to Orange/Black) as given below in Step #13. Either the power coil or power pack is the fault.
11. Remove the sensor wheel and check for damage, especially where the top slots are located. Sometimes the wheels will break out where the windows overlap.



The thin area between the crank position and the cylinder position is the most common breakout location.

12. Check the sensor eyes for dirt, grease, etc. If you have to clean it, use denatured alcohol and a Q-tip. Do not use any other cleaning agent because damage to the optical lens will occur.
13. Check the stator resistance and DVA voltage as given below for BOTH banks:

| WIRE        | READ TO      | RESISTANCE | DVA (Connected) | DVA (Disconnected) |
|-------------|--------------|------------|-----------------|--------------------|
| Brown       | Brown/Yellow | 450-600    | 150-400 V       | 150-400 V (*)      |
| Brown/White | Brown/Black  | 450-600    | 150-400 V       | 150-400 V (*)      |
| Orange      | Orange/Black | 45-60      | 11-22 V         | 45-120 V (*)       |

(\*) This reading can be used to determine if a stator or pack has a problem. For instance, if you have no spark on any cylinder and the stator's DVA reading is out of spec – disconnect the stator wires and recheck the DVA output. If the reading is still out of spec – the stator is bad. If the reading is now within spec – the pack is bad.

(NOTE) Low readings on all checks indicate a possible problem with the flywheel magnets that require checking.

(SERVICE NOTE) It is recommended that liquid neoprene be applied to the areas where piercing probes were used.

## **Johnson/Evinrude Troubleshooting**

14. Check the DVA output from the power pack to the primary coil wires as follows:

| WIRE         | READ TO       | DVA (Connected) |
|--------------|---------------|-----------------|
| Orange/Blue  | Engine Ground | 150 V +         |
| Orange       | Engine Ground | 150 V +         |
| Orange/Green | Engine Ground | 150 V +         |

(NOTE) If the DVA values are below these specifications, the power pack or sensor is likely bad.

15. Check the sensor DC voltage as follows:

| WIRE         | READ TO       | DC voltage (Connected) |
|--------------|---------------|------------------------|
| Orange/Red   | Engine Ground | 10.5-12 VDC            |
| Black/Orange | Engine Ground | 8-10 VDC               |

(WARNING!!) The Black/Orange wire should NEVER be shorted to engine ground as this will damage the sensor.

16. Check the charge coil flywheel magnets for cracked, broken and loose magnets.

### **ONLY HAS FIRE AS LONG AS THE KEY SWITCH IS ENGAGED OR WILL NOT REV ABOVE IDLE SPEED:**

Check the DVA voltage on the power coil (Orange to Orange/Black) as given in Step #13 on the previous page.

(NOTE) The readings should rapidly increase as the engine RPM increases and stabilize below 22 volts DVA (voltage exceeding 22 V DVA indicates a bad power pack). A sharp drop in voltage right before the miss becomes apparent usually indicates a bad stator winding. A sharp drop in voltage when you disengage the key switch indicates a bad power coil on the stator.

### **TRIES TO RUN BACKWARDS:**

1. Check the encoder wheel. It must have 7 notches.
2. Check the timing. Before Quick-Start, it must be set to 2-6° BTDC. After Quick-Start, it must be set to 4-8° ATDC.
3. Try another sensor.
4. Replace the power pack.

### **NO FIRE OR INTERMITTENT FIRE ON ONE BANK:**

1. Disconnect BOTH of the Black/Yellow stop wires AT THE POWER PACK and retest. If the engine's ignition has fire, the stop circuit has a fault. Check the key switch, harness and shift switch.
2. If possible, swap the stator wire pairs in the connector and see if the problem moves. If it does, the stator is bad.
3. Disconnect the Yellow wires from the stator to the rectifier and retest. If the engine now has fire, replace the rectifier.
4. Check the cranking RPM. A cranking speed of less than 250-RPM will not allow the system to fire properly. This can be caused by a weak battery, dragging starter, bad battery cables or a mechanical problem inside the engine.
5. Check the stator resistance and DVA output on BOTH banks (see Step #13 on NO FIRE ON ANY CYLINDER above).
6. Disconnect the 5-pin connector on the port side of the power pack and see if the fire returns. If it does fire, check resistance to see if the Black/Yellow or Black/Orange wire is shorted to engine ground. Check to see if the Shift Interrupter switch is located in the circuit where there is no fire.

## Johnson/Evinrude Troubleshooting

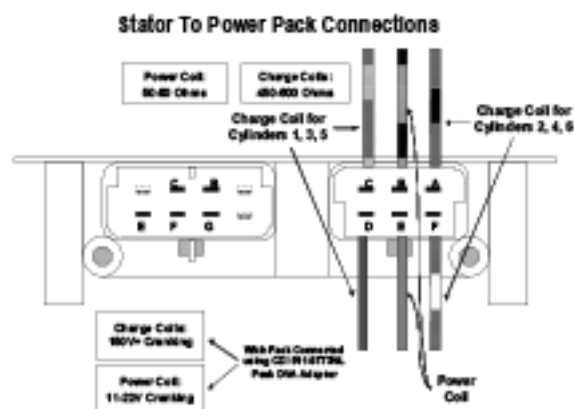

6 Pin Connector

- a) Brown/Black
- b) Orange/Black
- c) Brown/Yellow
- d) Brown
- e) Orange
- f) Brown/White

### POWER PACK OR TIMER BASE REPEATEDLY BLOWS ON SAME CYLINDER:

1. Check the sensor wires for shorts to engine ground as a shorted sensor wire can destroy a SCR inside the power pack.
2. In contrast, a shorted SCR inside the power pack can destroy a sensor coil. Check the sensor DVA output (see NO SPARK ON ANY CYLINDER above).
3. Replace the ignition coil on the cylinder dropping spark.

### ENGINE WILL NOT SHUT OFF:

Disconnect the stop wires at the power pack. Connect a jumper wire to the stop terminals in the pack and short them to engine ground. If this stops the pack from sparking, the stop circuit has a fault. Check the key switch, harness and shift switch. If this does not stop the pack from sparking, replace the power pack. Repeat test as necessary for additional packs.

### ONLY FIRES ON #1 CYLINDER:

Check the optical sensor to encoder wheel mesh. You may need to shim the optical sensor upwards 25/1000" to make it engage the encoder wheel more deeply.

### MISS AT ANY RPM:

1. Disconnect the Yellow wires from the stator to the rectifier and retest. If the miss clears, replace the rectifier.
2. In the water or on a Dynameters, check the DVA output on the Orange wires from the power pack while connected to the ignition coils. You should have a reading of at least 150V DVA or more, increasing with engine RPM until it reaches 300-400V DVA maximum. A sharp drop in DVA right before the miss becomes apparent on all cylinders will normally be caused by a bad stator. A sharp drop in DVA on less than all cylinders will normally be the power pack.
3. If the engine runs fine until you get above 4900 RPM and then starts missing, check the Orange to Orange/Black power coil wires with an oscilloscope (if available) or replace the pack. A breakdown inside the pack could cause RFI noise to activate the rev limiter for no apparent reason.
4. Connect an inductive tachometer to the spark plug wires one at a time and compare the readings. If most of the cylinders show the same reading and one or two show different readings, check the primary wires with the inductive pickup to see if the readings are the same from the power pack. A difference in readings between the primary and secondary coil wires usually indicates a bad coil or bad ignition wires. No difference indicates a bad power pack.
5. Perform a high-speed shutdown and read the spark plugs. Check for water. A crack in the block can cause a miss at high speed when the water pressure gets high, but a normal shutdown will mask the problem.

## **Johnson/Evinrude Troubleshooting**

6. Check the charge coil flywheel magnets for cracked, broken and loose magnets.

### **ENGINE WILL NOT REV ABOVE 2500 RPM AND SHAKES HARD (SLOW ACTIVATED):**

1. Verify the engine is not actually over-heating by using a digital pyrometer.
2. Check the routing of the tan temperature wires, an example of a bad location is shown below. The tan wires need to be located as far away as possible from the spark plug wires.

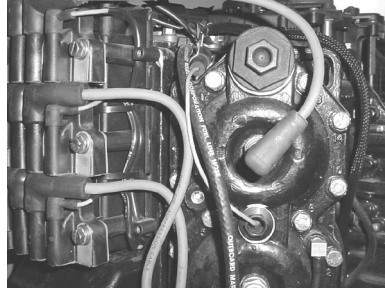

Unacceptable routing for the temp wire

3. Disconnect the temperature sensors and see if the engine performs normally. If it does, check both temperature sensors and replace the defective one.
4. If there is not any indication of a problem at this point, replace the power pack.

### **ENGINE STAYS IN QUICK-START:**

1. Check the Yellow/Red wire for DC volts while the engine is running. You should only see voltage on this wire while the starter solenoid is engaged. A DC voltage of 5-7 volts will not engage the starter solenoid, but will engage Quick-Start.
2. Short the White/Black temperature switch wire FROM the power pack to engine ground. Start the engine, if the Quick-Start drops out after approximately 5 seconds, replace the White/Black temperature switch.
3. Disconnect the Black/White wire from the power pack. If the Quick-Start feature is not now working, replace the power pack.

### **ENGINE DIES WHEN QUICK-START DROPS OUT:**

Check ignition timing at idle with the White/Black temperature wire disconnected. Remember to the timing will drop in when Quick-Start disengages. Therefore, the timing in QuickStart will be 10 degrees advanced with the White/Black wire disconnected. For a IDLE timing set point of 4-6 degrees ATDC, QuickStart will be at 6-4 degrees BTDC. Verify ignition timing after engine has warmed up, according to the service manual.

## **Mariner Troubleshooting**

### **Mariner**

#### **2 HP One Cylinder Engines 1977-1989 With Points Ignition**

**SERVICE NOTE:** These engines have the ignition coil under the flywheel. This system has the primary and the secondary side of the coil be separate, as the points drive the negative side of the coil to ground, causing the coil to generate spark on the secondary side.

##### **NO FIRE:**

1. Disconnect the White Kill and retest. If the engine now has fire, the stop circuit has a fault.
2. Check and clean the points. Point gap setting is 0.014 inches.
3. Check/replace the condenser.
4. Replace the ignition coil located under the flywheel.

##### **HAS FIRE BUT WILL NOT RUN:**

1. Check the flywheel shear key. Replace if sheared.
2. Reset the sparkplug air gap to the factory specification of 0.024 inches.

#### **2.5 and 3 HP One Cylinder Engine 1990-1992 With Points Ignition (Type I)**

##### **NO FIRE:**

1. Disconnect the Black Kill and retest. If the engine now has fire, the stop circuit has a fault.
2. Check and clean the points. Point gap setting is 0.012 to 0.016 inches.
3. Check/replace the condenser.
4. Check the ignition coil's primary resistance from the Black/White wire to engine ground. You should read 1.5 ohms +/- 0.2 ohms.
5. Check the ignition coil's secondary resistance from the sparkplug wire to engine ground. You should read 4.25K ohms to 5.75K ohms. If out of this range, replace the ignition coil.

##### **HAS FIRE BUT WILL NOT RUN:**

1. Check the flywheel shear key. Replace if sheared.
2. Reset the sparkplug air gap to the factory specification of 0.040 inches.

#### **2.5 and 3.3 HP One Cylinder Engine 1993-2006 With ADI Ignition (Type II) (823034)**

##### **NO FIRE:**

1. Disconnect the Brown Kill and retest. If the engine now has fire, the stop circuit has a fault.
2. Check the Charge Coil resistance. You should read from 300-400ohms from the White wire to engine ground.
3. Check the ignition coil's primary resistance from the Black/White wire to engine ground. You should read 1.5 ohms +/- 0.2 ohms.
4. Check the ignition coil's secondary resistance from the sparkplug wire to engine ground. You should read 4.25K ohms to 5.75K ohms. If out of this range, replace the ignition coil.

##### **HAS FIRE BUT WILL NOT RUN:**

1. Check the flywheel shear key. Replace if sheared.
2. Reset the sparkplug air gap to the factory specification of 0.040 inches.
3. Verify the cylinder compression is over 90 PSI.

##### **ENGINE IDLING VERY HIGH WITH THE THROTTLE PLTES CLOSED:**

Replace the CD module as the internal bias circuit is shorted.

#### **3.5 and 5 HP One Cylinder Engine 1977-1992 With Points Ignition (Type I)**

##### **NO FIRE:**

1. Disconnect the Black Kill and retest. If the engine now has fire, the stop circuit has a fault.
2. Check and clean the points. Point gap setting is 0.012 to 0.016 inches.
3. Check/replace the condenser.  
Check the ignition coil's primary resistance from the Black/White wire to engine ground. You should read 1.5 ohms +/- 0.2 ohms.
4. Check the ignition coil's secondary resistance from the sparkplug wire to engine ground. You should read 4.25K



## **Mariner Troubleshooting**

ohms to 5.75K ohms. If out of this range, replace the ignition coil.

### **HAS FIRE BUT WILL NOT RUN:**

3. Check the flywheel shear key. Replace if sheared.
4. Reset the sparkplug air gap to the factory specification of 0.040 inches.

### **4 and 5 HP Two Cylinder Engines 1990- With ADI Ignition (Type II)**

#### **NO FIRE:**

1. Disconnect the Brown Kill and retest. If the engine now has fire, the stop circuit has a fault.
2. Check the Charge Coil resistance. You should read from 93-142 ohms from the White wire to Black/Red wires.
3. Check the ignition coil's primary resistance from the spade connector to engine ground. You should read 0.02-0.38 ohms.
4. Check the ignition coil's secondary resistance from the sparkplug wire to engine ground. You should read 3K-4.4K ohms. If out of this range, replace the ignition coil.

### **HAS FIRE BUT WILL NOT RUN:**

1. Check the flywheel shear key. Replace if sheared.
2. Reset the sparkplug air gap to the factory specification of 0.040 inches.
3. Verify compression is over 90 PSI.

### **6, 8, 9.9, 15, 20 and 25 HP Two Cylinder Engines 1990- With ADI Ignition (Type II) (339-7452/114-7452 IGNITION)**

#### **NO FIRE ON EITHER CYLINDER:**

1. Disconnect the Brown Kill and retest. If the engine now has fire, the stop circuit has a fault.
2. Check the Stator and Trigger DVA/ resistance.

| WIRE<br>(Disconnected) | READ TO     | OEM RESISTANCE | CDI RESISTANCE | DVA (Connected) | DVA           |
|------------------------|-------------|----------------|----------------|-----------------|---------------|
| Black/Yellow           | Engine GND  | 3250-3800      | 2200-2400      | 180-400 V       | 180-400 V (*) |
| Black/White            | Engine GND  | 150-250        | 200-250        | 25-100 V        | 25-100 V (*)  |
| Brown/Yellow           | Brown/White | 750-1400       | 925-1050       | 4 V +           | 4 V + (#)     |
| Brown/Yellow           | Engine GND  | Open           | Open           | 1 V +           | N/A           |
| Brown/White            | Engine GND  | Open           | Open           | 1 V +           | N/A           |

(\*) This reading can be used to determine if a stator or pack has a problem. For instance, if you have no spark on any cylinder and the stator's DVA reading is low – disconnect the stator wires and recheck the DVA output. If the reading stays low – the stator is bad. If the reading is now within spec – the pack is bad.

(#) This reading can be used to determine if a pack has a problem in the triggering circuit. For instance, if you have no spark on one cylinder and the trigger's DVA reading for that cylinder is low – disconnect the trigger wires and recheck the DVA output. If the reading stays low – the trigger is bad. If the reading is now within spec – the pack is bad.

3. Disconnect the Black/Yellow stop wire AT THE SWITCH BOX and retest. If the engine's ignition now has spark, the stop circuit has a fault. Check the key switch, harness and shift switch.
4. Check the cranking RPM. A cranking speed of less than 250-RPM will not allow the system to spark properly. This can be caused by a weak battery, dragging starter, bad battery cables or a mechanical problem inside the engine.
5. Inspect and clean all engine and ignition ground connections.

6. Check the stator resistance and DVA output:

| WIRE         | READ TO    | OEM RESISTANCE | CDI RESISTANCE | DVA (Connected) | DVA (Disconnected) |
|--------------|------------|----------------|----------------|-----------------|--------------------|
| Black/Yellow | Engine GND | 3250-3800      | 2200-2400      | 180-400 V       | 180-400 V (*)      |
| Black/White  | Engine GND | 150-250        | 200-250        | 25-100 V        | 25-100 V (*)       |

(\*) This reading can be used to determine if a stator or pack has a problem. For instance, if you have no spark on any cylinder and the stator's DVA reading is low – disconnect the stator wires and recheck the DVA output. If the reading stays low – the stator is bad. If the reading is now within spec – the pack is bad.

7. Check the triggering and charge coil flywheel magnets for cracked, broken and loose magnets.

#### **NO SPARK OR INTERMITTENT SPARK ON ONE CYLINDER:**

## Mariner Troubleshooting

1. Check the trigger resistance and DVA output:

| WIRE         | READ TO     | OEM RESISTANCE | CDI RESISTANCE | DVA (Connected) | DVA (Disconnected) |
|--------------|-------------|----------------|----------------|-----------------|--------------------|
| Brown/Yellow | Brown/White | 750-1400       | 925-1050       | 4 V +           | 4 V + (#)          |
| Brown/Yellow | Engine GND  | Open           | Open           | 1 V +           | N/A                |
| Brown/White  | Engine GND  | Open           | Open           | 1 V +           | N/A                |

(#) This reading can be used to determine if a pack has a problem in the triggering circuit. For instance, if you have no spark on one cylinder and the trigger's DVA reading for that cylinder is low – disconnect the trigger wires and recheck the DVA output. If the reading stays low – the trigger is bad. If the reading is now within spec – the pack is bad.

2. Check the DVA output on the Green wires from the switch box while connected to the ignition coils. Check the reading on the switch box terminal AND on the ignition coil terminal. You should have a reading of at least 150V or more at both places. If the reading is low on one cylinder, disconnect the Green wire from the ignition coil for that cylinder and reconnect it to a load resistor. Retest. If the reading is now good, the ignition coil is likely bad. A continued low reading indicates a bad switch box.
3. Check the ignition coil's primary resistance from the Positive (+) Terminal to the Negative (-) Terminal. You should read 0.02-0.04 ohms.
4. Check the ignition coil's secondary resistance from the sparkplug wire to engine ground. You should read 800-1.1K ohms. If out of this range, replace the ignition coil.
5. Connect an inductive tachometer to each cylinder and compare the RPM readings at the RPM where the problem is occurring. If only one cylinder is dropping out, swap the ignition coil locations and retest. If the problem follows a coil, replace the coil. If it stays on the same spark plug, replace the switch box.
6. Check the triggering and charge coil flywheel magnets for cracked, broken and loose magnets.

### SWITCH BOX OR TRIGGER REPEATEDLY BLOWS ON SAME CYLINDER:

1. Check the trigger wires for shorts to engine ground as a shorted trigger wire can destroy a SCR inside the switch box.
2. In contrast, a shorted SCR inside the switch box can destroy a trigger coil. Check the trigger resistance and DVA output (see NO SPARK OR INTERMITTENT SPARK ON ONE CYLINDER above).
3. Replace the ignition coil on the cylinder dropping spark.

### ENGINE WILL NOT SHUT OFF:

Disconnect the Black/Yellow stop wire at the switch box. Connect a jumper wire to the Black/Yellow stop terminal (or wire) from the switch box and short it to engine ground. If this stops the switch box from sparking, the stop circuit has a fault. Check the key switch, harness and shift switch. If this does not stop the switch box from sparking, replace the switch box. Repeat test as necessary for additional switch boxes.

### WILL NOT ACCELERATE BEYOND 3000-4000 RPM:

1. Connect a DVA meter between the stator's Black/Yellow wire/terminal and engine ground. Run the engine up to the RPM where the problem is occurring. DVA voltage should increase with RPM. A sharp drop in DVA right before the problem occurs usually indicates a bad stator.
2. Connect a DVA meter between the stator's Black/White wire/terminal and engine ground. The DVA voltage should show a smooth climb in voltage and remain high through the RPM range. A reading lower than on the Black/Yellow wire/terminal reading indicates a bad stator.
3. Connect an inductive tachometer to each cylinder in turn and try to isolate the problem. A single cylinder dropping spark will likely be a bad switch box or ignition coil. All cylinders not sparking properly usually indicates a bad stator.
4. Perform a high-speed shutdown and read the spark plugs. Check for water. A crack in the block can cause a miss at high speed when the water pressure gets high, but a normal shutdown will mask the problem.
5. Check the triggering and charge coil flywheel magnets for cracked, broken and loose magnets.

### MISS AT ANY RPM:

## ***Mariner Troubleshooting***

1. Disconnect the Yellow wires from the stator to the rectifier and retest. If the miss clears, replace the rectifier.
2. In the water or on a Dynameters, check the DVA output on the Green wires from the switch box while connected to the ignition coils. You should have a reading of at least 150V DVA or more, increasing with engine RPM until it reaches 300-400V DVA maximum. A sharp drop in DVA right before the miss becomes apparent on all cylinders will normally be caused by a bad stator. A sharp drop in DVA on less than all cylinders will normally be the switch box or trigger.
3. Connect an inductive tachometer to each cylinder in turn and try to isolate the problem. A high variance in RPM on one cylinder usually indicates a problem in the switch box or ignition coil. Occasionally a trigger will cause this same problem. Check the trigger DVA voltage (see NO SPARK OR INTERMITTENT SPARK ON ONE CYLINDER above).
4. Perform a high-speed shutdown and read the spark plugs. Check for water. A crack in the block can cause a miss at high speed when the water pressure gets high, but a normal shutdown will mask the problem.
5. Check the triggering and charge coil flywheel magnets for cracked, broken and loose magnets.

**SERVICE NOTE: Refer to the Mercury section as the remainder of the Mariner Engines use the Mercury ignition system.**

## **Mercury Troubleshooting**

### **Mercury Battery CD Ignitions**

#### **GENERAL:**

1. Clean all battery connections and engine grounds.
2. Disconnect the mercury tilt switch and retest. If the ignition works properly, replace or discard the mercury tilt switch.
3. Connect a spark gap tester to the spark plug wires and check for spark on all cylinders. If some cylinders spark and not others, the problem is likely in the distributor cap, rotor button or spark plug wires.
4. Perform a voltage drop test after the engine is repaired to see if there is a problem with the voltage going to the CD module. At cranking and while the engine is running, use a DC voltmeter and put the Black meter lead on the battery POS (+) post and the Red meter lead on the positive battery cable at the starter solenoid. Keep the Black lead on the battery post and shift the Red meter lead to the positive post of the rectifier, then to the Red and White terminals on the switch box. If you find a reading above 0.6V, there is a problem at the point where the voltage jumped up. For example, if the meter reads 0.4V until you get to the White terminal and then jumps to 2.3V on the White terminal – this indicates a problem in the key switch, or harness. Repeat the test for the negative battery post by putting the Black meter lead on the battery NEG (-) post and the Red meter lead on the negative battery cable terminal, then shifting to the engine block, rectifier base and case ground of the CD module.

#### **NO SPARK ON ANY CYLINDER:**

1. If a mercury tilt switch is connected to the switch box, disconnect it and retest. If you now have spark, replace or discard the mercury tilt switch.
2. Check DC voltage on the White and Red terminals (White/Red wire on the 114-2986) (they must be connected to the switch box) to Engine Ground AT CRANKING. It MUST be at least 9.5 volts. If not, there is most likely a problem in the battery. Try a known-good non-maintenance-free cranking battery. If no change, check the key switch, starter and battery cables.
3. Perform the jumper wire test in the illustration above. Disconnect the trigger wires from the switch box and connect a jumper wire from the Brown trigger terminal/wire of the switch box to the White trigger terminal/wire of the switch box. Connect another jumper wire to the Black trigger terminal/wire of the switch box. Turn the ignition switch to ON. Strike the jumper wire from the Black trigger terminal/wire against Engine Ground – (DO NOT HOLD THE JUMPER AGAINST ENGINE GROUND). The ignition coil should spark each time the Black wire is tapped to Engine Ground. If not, the switch box and/or ignition coil is faulty.
4. Connect a spark gap tester to the high-tension lead coming from the ignition coil and set it to approximately 7/16". When you crank the engine over, if it sparks while the spark gap tester is connected to the coil and does not spark through the spark plug wires – there is a problem in the distributor cap, rotor button or spark plug wires.
5. Check DC voltage on the Brown trigger terminal/wire (it must be connected to the switch box) to Engine Ground AT CRANKING. It must be at least 9V DC. A low reading indicates a bad switch box.
6. Check DVA voltage between the White and Black trigger terminals/wires (they must be connected to the switch box) AT CRANKING. It must be at least 3V DVA. A low reading indicates a bad trigger.
7. Check DVA voltage on the Green wire going to the coil to Engine Ground AT CRANKING. It must be at least 100V DVA on an OEM switchbox (200V on a CDI Electronics Switchbox). A low reading indicates a bad switch box.

#### **ONLY HAS SPARK AS LONG AS THE STARTER IS ENGAGED:**

This symptom usually indicates a bad trigger or low battery voltage.

#### **NO SPARK OR INTERMITTENT SPARK ON ONE CYLINDER:**

1. Connect a spark gap tester to the high-tension leads coming from the distributor cap and set the gap to approximately 7/16". (Use of a CD Tester is recommended).
2. Align the rotor with #1 spark plug wire. Disconnect the trigger wires from the switch box and connect a jumper wire from the Brown trigger terminal/wire of the switch box to the White trigger terminal/wire of the switch box.
3. Connect another jumper wire to the Black trigger terminal/wire of the switch box. Turn the ignition switch to ON. Strike the jumper wire from the Black trigger terminal/wire against Engine Ground – (DO NOT HOLD THE JUMPER AGAINST ENGINE GROUND). Only the #1 spark plug wire should spark. If any other spark plug wire has spark, there is a problem in the distributor cap.
4. Repeat the test for the other cylinders.

## Mercury Troubleshooting

### MISS AT ANY RPM:

1. Check the battery voltage on the Red and White terminals (White/Red wire on the 114-2986) (they must be connected to the switch box) to Engine Ground throughout the RPM range. The voltage should be between 12V and 16V DC. A reading outside this range will damage the CD module. If the readings are abnormal, perform the voltage drop test described above.
2. Perform a high-speed shutdown and read the spark plugs. Check for water. A crack in the block can cause a high miss at high speed when the water pressure gets high, but a normal shutdown will mask the problem.

### TRIES TO RUN BACKWARDS:

Check timing and timing belt.

### **Mercury** Battery CD Ignitions with Points 1966-1967 Models 950 and 1100 (With 114-2803/332-2803 Switch Box)

(SERVICE NOTE) Check the battery voltage at approximately 3500-RPM. The MAXIMUM reading allowable is 16 volts. Over 16 volts will damage the ignition. Check for loose connections or a bad battery.. Maintenance free batteries are NOT recommended for this application. A CD Tester (CDI Electronics P/N: 511-9701) can be used to test the CD module, distributor cap, rotor button and spark plug wires on the engine.

Technical Information: The points set at 0.005 on each set as a preliminary setting. Dwell must be set at 55 degrees with a dwell meter.

#### Engine Wiring Connection for Testing Ignition Module

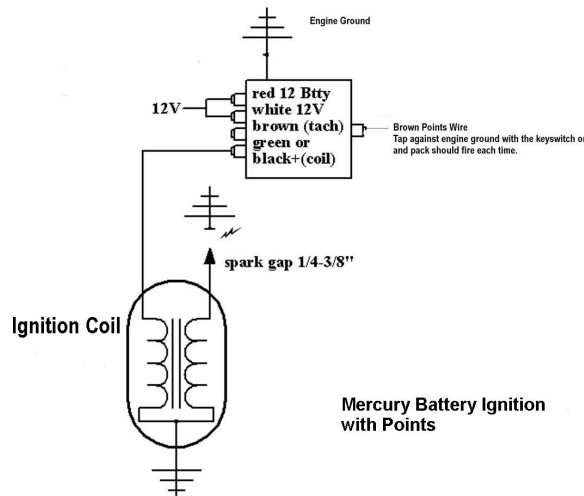

1. Clean all battery connections and engine grounds.
2. Disconnect the mercury tilt switch and retest. If the ignition works properly, replace the mercury switch.
3. Connect a spark gap tester to the spark plug wires and check for spark on all cylinders. If some cylinders spark and not others, the problem is likely in the distributor cap, rotor button or spark plug wires.
4. Connect a spark gap tester to the high-tension lead coming from the ignition coil and set it to approximately 7/16". When you crank the engine over, if it sparks while the spark gap tester is connected to the coil and does not spark through the spark plug wires – there is a problem in the distributor cap, rotor button or spark plug wires.
5. Check voltage present on the White and Red terminals (White wire on the 114-2803) while at cranking. It MUST be at least 9.5 volts. If not, there is a problem in the harness, key switch, starter battery cables or battery.
6. Check DVA voltage on the Green wire going to the coil, it should be over 100 volts at cranking.
7. Disconnect the Brown points wires. Turn the ignition switch on and strike one of the Brown points wire against engine ground. The unit should spark each time. If the coil does spark, this means the CD module is usually good and the points, points plate and grounding wire for the points plate should be checked.
8. Connect a spark gap tester to the high-tension leads coming from the distributor cap and set the gap to





## **Mercury Troubleshooting**

### **NO SPARK ON ANY CYLINDER:**

1. If a mercury tilt switch is connected to the switch box, disconnect it and retest. If you now have spark, replace or discard the mercury tilt switch.
2. Check DC voltage on the White and Red terminals (White wire on the 114-4796) (they must be connected to the switch box) to Engine Ground AT CRANKING. It MUST be at least 9.5 volts. If not, there is most likely a problem in the battery. Try a known-good non-maintenance-free cranking battery. If no change, check the key switch, starter and battery cables.
3. Perform the jumper wire test in the illustration above. Disconnect the trigger wires from the switch box and connect a jumper wire from the Black trigger terminal/wire of the switch box to the White/Black trigger terminal/wire of the switch box. Connect another jumper wire to the Blue trigger terminal/wire of the switch box. Turn the ignition switch to ON. Strike the jumper wire from the Blue trigger terminal/wire against Engine Ground – (DO NOT HOLD THE JUMPER AGAINST ENGINE GROUND). The ignition coil should spark each time the Blue wire is tapped to Engine Ground. If not, the switch box and/or ignition coil is faulty.
4. Connect a spark gap tester to the high-tension lead coming from the ignition coil and set it to approximately 7/16". When you crank the engine over, if it sparks while the spark gap tester is connected to the coil and does not spark through the spark plug wires – there is a problem in the distributor cap, rotor button or spark plug wires.
5. Check DC voltage on the White/Black trigger terminal/wire (it must be connected to the switch box) to Engine Ground AT CRANKING. It must be at least at least 9V DC. A low reading indicates a bad switch box.
6. Check DVA voltage between the Blue and Black trigger terminals/wires (they must be connected to the switch box) AT CRANKING. It must be at least 3V DVA. A low reading indicates a bad trigger.
7. Check DVA voltage on the Green wire going to the coil to Engine Ground AT CRANKING. It must be at least 100V DVA on an OEM switchbox (200V on a CDI Electronics Switchbox). A low reading indicates a bad switch box.

### **ONLY HAS SPARK AS LONG AS THE STARTER IS ENGAGED:**

This symptom usually indicates a bad trigger or low battery voltage.

### **NO SPARK OR INTERMITTENT SPARK ON ONE CYLINDER:**

1. Connect a spark gap tester to the high-tension leads coming from the distributor cap and set the gap to approximately 7/16". Use of a CD Tester is highly recommended.
2. Align the rotor with #1 spark plug wire. Disconnect the trigger wires from the switch box and connect a jumper wire from the Black trigger terminal/wire of the switch box to the White/Black trigger terminal/wire of the switch box.
3. Connect another jumper wire to the Blue trigger terminal/wire of the switch box. Turn the ignition switch to ON. Strike the jumper wire from the Blue trigger terminal/wire against Engine Ground – (DO NOT HOLD THE JUMPER AGAINST ENGINE GROUND). Only the #1 spark plug wire should spark. If any other spark plug wire has spark, there is a problem in the distributor cap.
4. Repeat the test for the other cylinders.

### **MISS AT ANY RPM:**

1. Check the battery voltage on the Red and White terminals (White wire on the 114-4796) (they must be connected to the switch box) to Engine Ground throughout the RPM range. The voltage should be between 12V and 16V DC. A reading outside this range will damage the CD module. If the readings are abnormal, perform the voltage drop test described above.
2. Perform a high-speed shutdown and read the spark plugs. Check for water. A crack in the block can cause a high miss at high speed when the water pressure gets high, but a normal shutdown will mask the problem.

### **TRIES TO RUN BACKWARDS:**

Check timing and timing belt.

## **Four and Six Cylinder Engines (With 114-2986/332-2986/393-3736 Switch Box)**

(Note) A CD Tester like the one by CDI Electronics or Merc-o-Tronics can be used to test the CD module, distributor cap, rotor button and spark plug wires on the engine while the Trigger Tester by CDI can be used to test the distributor trigger.

## Mercury Troubleshooting

(SERVICE NOTE) Check the battery voltage at approximately 3500 RPM, MAXIMUM reading allowable is 16 volts and minimum is 12V. Running below 12V or over 15.5V may damage the ignition. Check for loose connections or a bad battery. Maintenance free batteries are NOT recommended for this application.

### Engine Wiring Connection for Testing Ignition Module

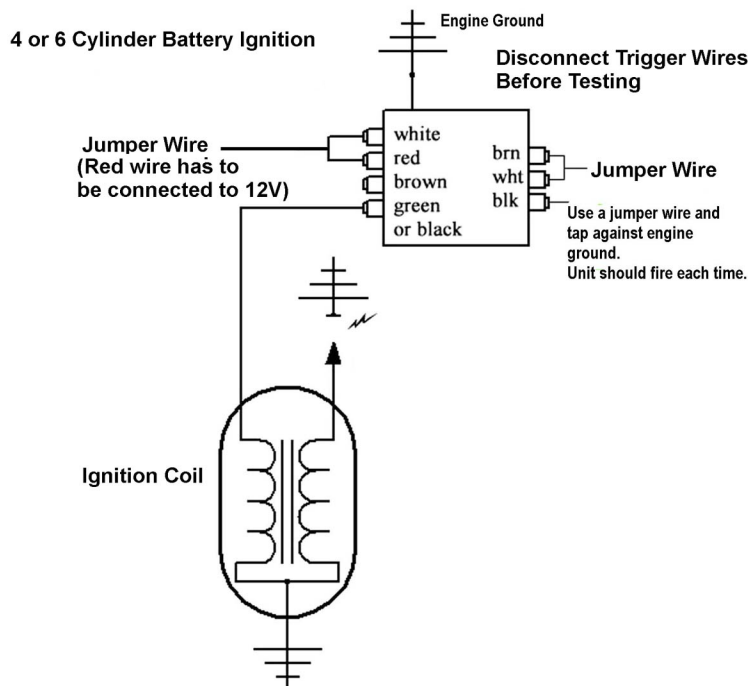

#### NO FIRE ON ANY CYLINDER:

1. Clean all battery connections and engine grounds.
2. Disconnect the mercury tilt switch and retest. If the ignition works properly, replace the mercury switch.
3. Connect a spark gap tester to the spark plug wires and check for fire on all cylinders. If some cylinders fire and not others, the problem is likely in the distributor cap, rotor button or spark plug wires. Notice: If the unit only fires when you let off of the key switch, the trigger is usually the problem.
4. If the trigger is one manufactured by CDI Electronics, verify the disk used in the trigger is the steel disk – not the copper one.
5. Check voltage present on the White wire (White/Red wire in Switch) at cranking. It MUST be at least 9½ volts. If not, the problem is in the harness, key switch, starter or battery.
6. Check voltage present on the Brown Trigger wire at cranking. It MUST be at least 9 volts. If not, the problem's likely in the pack.
7. Check DVA voltage on the Green wire going to the coil. It should be approximately 200 volts at cranking.
8. With the spark gap tester to the high tension lead coming from the ignition coil, disconnect the Brown, White and Black trigger wires. Connect a jumper wire from the slot for the Brown wire to the slot for the White wire. Connect another jumper to the slot for the Black wire and (with the key switch turned on) strike the jumper against engine ground. The unit should fire each time. If it does, the CD module is usually good. See diagram on the next page.
9. Perform a voltage drop test after the engine is repaired to see if there is a problem with the voltage going to the CD module. At cranking and while the engine is running, use a DC voltmeter and put the black meter lead on the battery POS (+) post and the red meter lead on the positive battery cable at the starter solenoid. Keep the black lead on the battery post and shift the red meter lead to the positive post of the rectifier, then to the red and white terminals on the switch box. If you find a reading above 0.6V, there is a problem at the point where the voltage jumped up. For example, if the meter reads 0.4V until you get to the white terminal and then jumps to 2.3V on the white terminal –this indicates a problem in the key switch, or harness. Repeat the test for the negative battery post by putting the black meter lead on the battery NEG (-) post and the red meter lead on the negative battery cable terminal, then shifting to the engine block, rectifier base and case ground of the CD module.

## **Mercury Troubleshooting**

### **ONLY HAS SPARK AS LONG AS THE STARTER IS ENGAGED:**

This symptom usually indicates a bad trigger or low voltage.

### **NO SPARK OR INTERMITTENT SPARK ON ONE CYLINDER:**

1. Connect a spark gap tester to the high-tension leads coming from the distributor cap and set the gap to approximately 7/16". (Use of a CD Tester is recommended).
2. Align the rotor with #1 spark plug wire. Disconnect the trigger wires and connect a jumper wire from the brown trigger terminal to the white trigger terminal.
3. Connect another jumper wire to the black trigger terminal turn the ignition switch on. Strike the jumper wire from the black terminal against engine ground – (DO NOT HOLD THE JUMPER AGAINST ENGINE GROUND). Only the #1 spark plug wire should fire. If any other spark plug wire has fire, there is a problem in the distributor cap.
4. Repeat the test for the other cylinders.

### **HIGH SPEED MISS:**

1. Check the battery voltage on the red and white terminals of the switch box at high speed, the voltage should be between 12.5V and 16V DC. A reading outside this range will damage the CD module. If the readings are abnormal, perform the voltage drop test described above.
2. Perform a high-speed shutdown and read the spark plugs. Check for water. A crack in the block can cause a high miss at high speed when the water pressure gets high, but a normal shutdown will mask the problem.

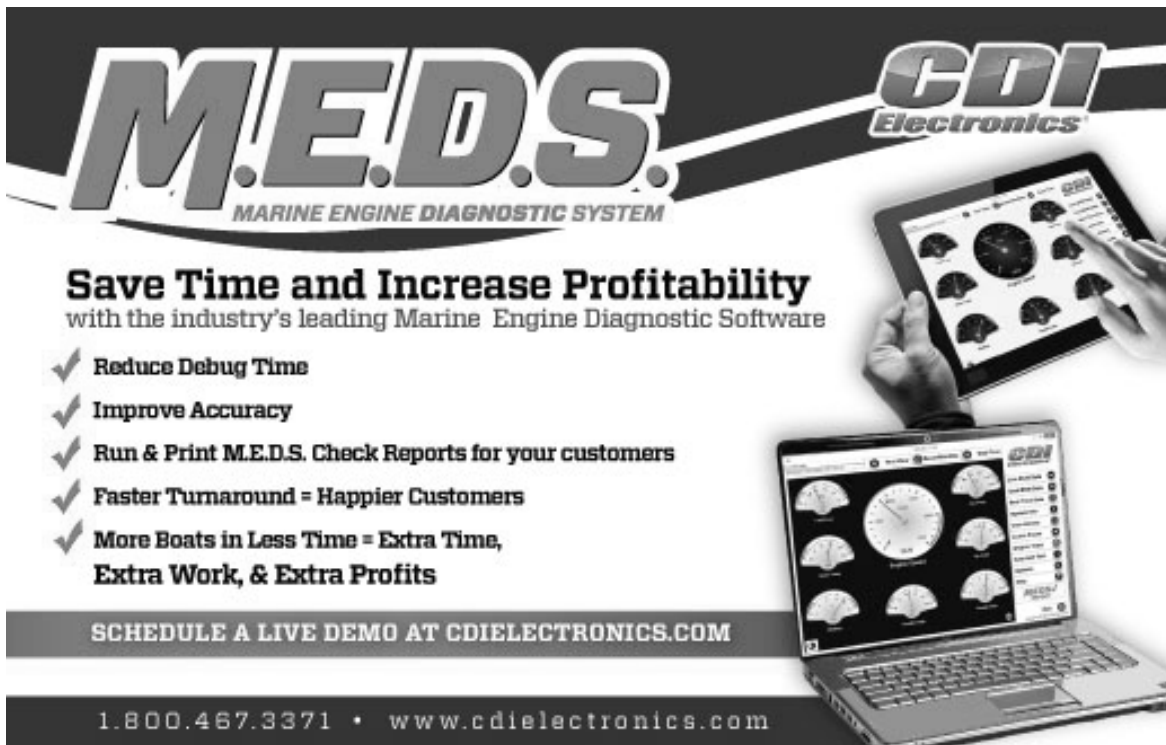

**M.E.D.S.**  
MARINE ENGINE DIAGNOSTIC SYSTEM

**CDI Electronics**

**Save Time and Increase Profitability**  
with the industry's leading Marine Engine Diagnostic Software

- ✓ Reduce Debug Time
- ✓ Improve Accuracy
- ✓ Run & Print M.E.D.S. Check Reports for your customers
- ✓ Faster Turnaround = Happier Customers
- ✓ More Boats in Less Time = Extra Time, Extra Work, & Extra Profits

SCHEDULE A LIVE DEMO AT [CDIELECTRONICS.COM](http://CDIELECTRONICS.COM)

1.800.467.3371 • [www.cdielelectronics.com](http://www.cdielelectronics.com)

## Mercury Troubleshooting

Mercury Trigger Magnets  
THE FLYWHEELS WITH THESE MAGNET DESIGNS CANNOT BE INTERCHANGED!!!!

### Mercury CDM Hub Magnet Design

1996 to 2006 2, 3 and 4 cylinder engines with CDM Modules

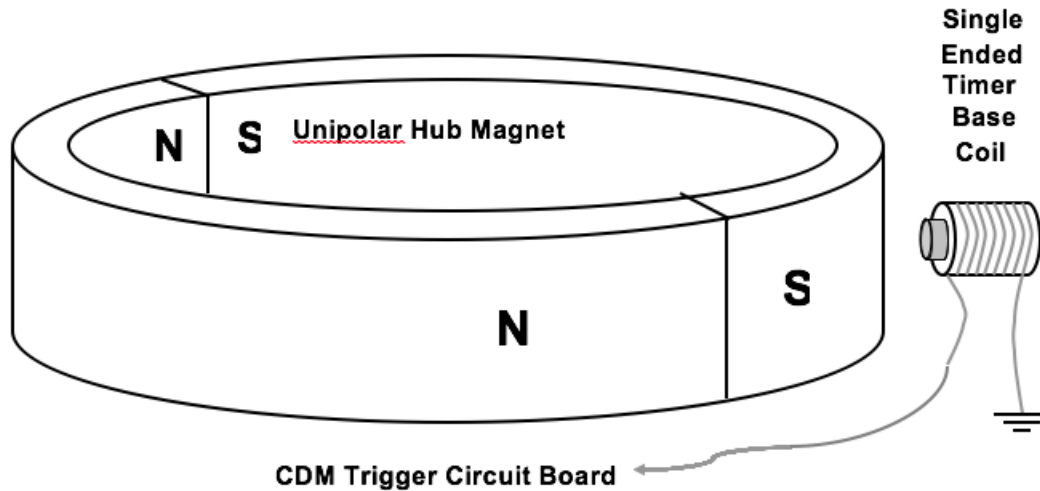

### Mercury Hub Magnet Design

Push-Pull Trigger Coil Design (1978-1996 on 2, 3 and 4 Cyl engines All 1978-2005 L6, 2.0L, 2.4L and 2.5L engines)

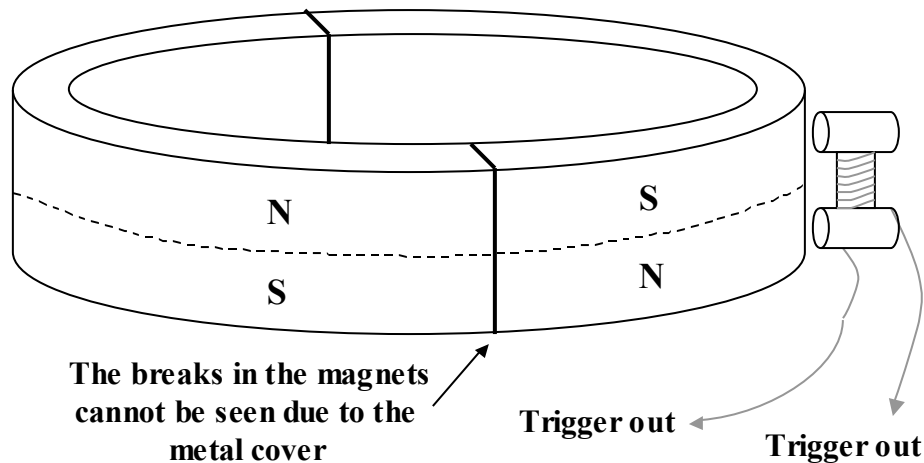

Note that the design of the magnet for the push-pull is the same for the 3, 4 and 6 cylinder engines using standard ADI ignitions. The trigger magnet for the CDM modules is completely different.



# Mercury Troubleshooting

## Mercury

### Alternator Driven Ignitions

#### One and Two Cylinder Engines 1971-1975 (With 336-4516 Phase-Maker Ignition)

**SERVICE NOTE:** These engines require the Orange, Red or Green Ignition coils. The Black or Blue ignition coils use a common ground connection internally for the primary and the secondary side of the coils. This system requires that the primary and the secondary side of the coils be separate as the points drive the negative side of the coil to ground, causing the coil to generate spark on the secondary side.

**NO SPARK ON ONE OR BOTH CYLINDERS:**

1. Disconnect the Orange stop and connect it to engine ground. Retest. If the engine now has spark, the stop circuit has a fault.
2. Check the stator resistance and DVA output as given below:
 

| WIRE  | READ TO       | OEM RESISTANCE      | CDI RESISTANCE | DVA (Connected) |
|-------|---------------|---------------------|----------------|-----------------|
| Red   | Yellow        | 3200-4000 (1972-73) | 2000-2400      | N/A             |
| Red   | Yellow        | 5300-6100 (1974-UP) | 2000-2400      | N/A             |
| Blue  | Yellow        | 160-200             | 140-180        | N/A             |
| Green | Engine Ground | --                  | --             | 180 V +         |
3. Disconnect the Brown and White points wires one at a time and retest. If the spark comes back on the one still connected when you disconnect one of them, the points or points wire is defective for the disconnected cylinder.
4. Disconnect the Green wires one at a time and retest. If the spark comes back on one cylinder, the ignition coil not connected is defective. Remember that the coils must not be the Black or Blue coils (these coils are not isolated ground).
5. Test the 336-4516 module as follows:

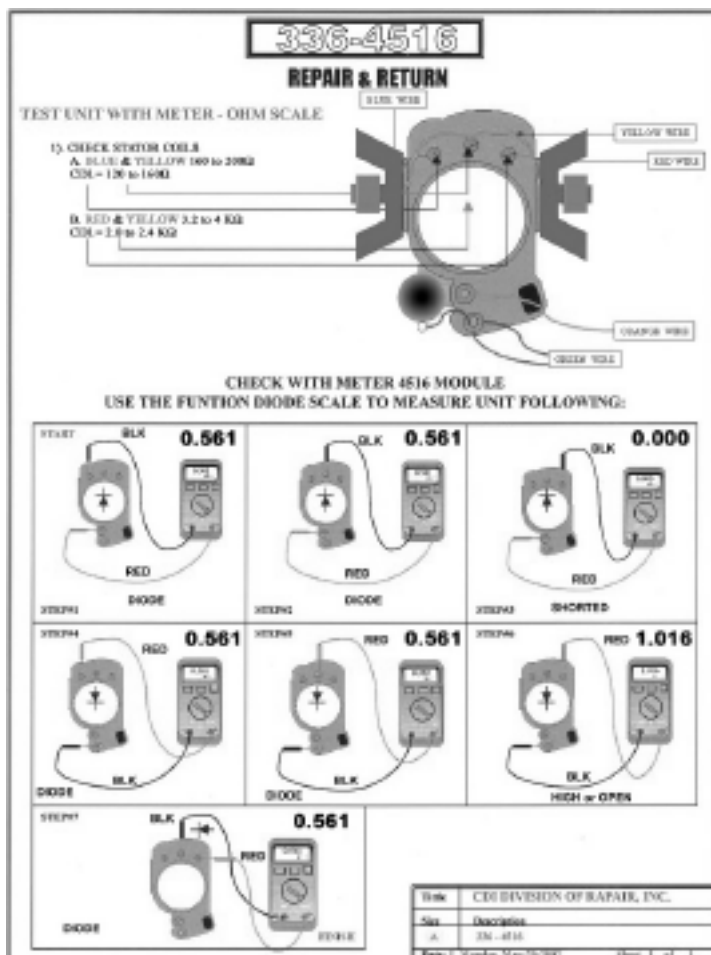

**Mercury**

## Mercury Troubleshooting

### Mercury

#### One and Two Cylinder Engines 1966-1985 (With 174-3996/336-3996/336-3962 Stator/Switch Box)

**WARNING!! DO NOT START AND RUN THIS ENGINE ON A FLUSHING ATTACHMENT OR EAR MUFFS AND ACTIVATE THE STOP CIRCUIT.** This system operates with the Orange stop wire normally shorted to ground. When you activate the stop circuit, you open the Orange's connection to ground. The resulting backlash into the stator may damage the electronics. You must use the choke to stop the engine. In the water, the back pressure from the exhaust will slow the engine quickly enough to prevent damage to the stator.

(Note) The insulator blocks used with this stator are very important. You are strongly advised to closely inspect the Brown and White points wires and insulator blocks for cracking or arcing. This system operates at a much higher voltage than the normal systems and what would be acceptable on other systems will cause arcing problems.

**SERVICE NOTE:** These engines require the Orange, Red or Green Ignition coils. The Black or Blue ignition coils use a common ground connection internally for the primary and the secondary side of the coils. This system requires that the primary and the secondary side of the coils be separate as the points drive the negative side of the coil to ground, causing the coil to generate spark on the secondary side.

#### NO SPARK ON ANY CYLINDER:

1. Disconnect the Orange stop wire and connect it to engine ground. Retest. If the ignition system now has spark, the stop circuit has a problem.
2. Disconnect the Brown and White points wires from the ignition coils and connect a jumper wire to the negative side of the coils. Crank the engine and carefully tap the jumper to engine ground, if the coil sparks – check the points and points wires. If it fails to spark, inspect the ignition coil. You should have either a Red, Orange or Green coil with a bare braided ground wire from the backside of the coil. This bare braided ground wire **MUST** be connected to a clean engine ground. You cannot use a Black or Blue ignition coil.

#### NO SPARK ON ONE CYLINDER:

1. Disconnect the Brown and White points wires from the ignition coils and swap them for a cranking test. Crank the engine over and see if the spark moves to a different coil. If it does, you have a problem in the points, points wire or insulator block for the cylinder not sparking.
2. If the spark remains on the same coil when you swap the points wires and it is the coil where the Green wire is coming from the stator, remove the Green jumper wire. Swap the Green wire coming from the stator from one coil to the other coil. If the spark moves to the other coil, replace the Green jumper wire connecting the two coils.
3. Check the ignition coil. You should have approximately 1,000 (1 K ohm) of resistance from the spark plug wire to engine ground using the Orange coil and 600 ohms for the Green coil.
4. Inspect the ignition coils. You should have either a Red, Orange or Green coil with a bare braided ground wire from the backside of the coil. This bare braided ground wire **MUST** be connected to a clean engine ground. You cannot use a Black or Blue ignition coil.

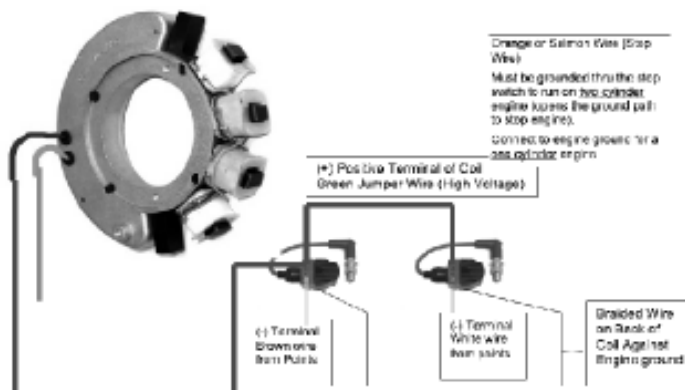

# Mercury Troubleshooting

## Mercury

### 1970-1975 Four Cylinder Engines (With 333-3213 Switch Box) (With Ignition Driver Distributors)

**WARNING!! DO NOT CONNECT 12VDC TO THE IGNITION MODULE AS DC VOLTAGE WILL SEVERELY DAMAGE THE SWITCH BOX AND IGNITION DRIVER.**

**NO SPARK ON ANY CYLINDER:**

1. Disconnect the Orange (or Blue) stop wire AT THE SWITCH BOX and retest. If the engine's ignition now has spark, the stop circuit has a fault. Check the key switch, harness and shift switch.
2. Check the cranking RPM. A cranking speed of less than 250-RPM will not allow the system to spark properly. This can be caused by a weak battery, dragging starter, bad battery cables or a mechanical problem inside the engine.

3. Check the Ignition Driver resistance and DVA output:

| WIRE  | READ TO   | FUNCTION           | RESISTANCE | DVA (Connected) |
|-------|---|--------------------|------------|-----------------|
| Red   | White wire  | Cranking Winding   | 400 ohms   | 180-400 V       |
| Blue  | White wire  | High Speed Winding | 10 Ohms    | 25-100 V        |
| Green | Engine GND  | Pack output        | N/A        | 150 V +         |
| White | Common for Ignition Driver (DOES NOT CONNECT TO ENGINE GND) |                    |            |                 |

4. Check the Ignition pack resistance:

| RED METER LEAD   | BLACK METER LEAD | READING |
|------------------|------------------|---------|
| Red Terminal     | Pack Case Ground | Diode   |
| Pack Case Ground | Red Terminal     | Open    |
| Blue Terminal    | Pack Case Ground | Diode   |
| Pack Case Ground | Blue Terminal    | Open    |
| White Terminal   | Pack Case Ground | Diode   |
| Pack Case Ground | White Terminal   | Open    |
| Green            | Engine Ground    | Open    |
| Pack Case Ground | Green Terminal   | Diode   |

**NO SPARK ON ONE OR MORE CYLINDERS:**

If only one or two cylinders are not firing on this system, the problem will be either in the distributor cap or spark plug wires.

### Two Cylinder Engines 1974-1985 (With 114-6222/339-6222/339-5287 Switch Box)

**SERVICE NOTE:** These engines require the Orange, Red or Green Ignition coils. The Black or Blue ignition coils use a common ground connection internally for the primary and the secondary side of the coils. This system requires that the primary and the secondary side of the coils be separate as the pack drives the negative side of the coil to ground, causing the coil to generate spark on the secondary side.

**NO SPARK ON ANY CYLINDER:**

1. Disconnect the Orange stop wire AT THE SWITCH BOX and retest. If the engine's ignition now has spark, the stop circuit has a fault. Check the key switch, harness and shift switch.
2. Disconnect the Yellow wires from the stator to the rectifier and retest. If the engine sparks, replace the rectifier.
3. Check the cranking RPM. A cranking speed of less than 250-RPM will not allow the system to spark properly. This can be caused by a weak battery, dragging starter, bad battery cables or a mechanical problem inside the engine.

4. Inspect and clean all engine and ignition ground connections.

5. Check the stator and trigger resistance and DVA output:

| WIRE   | READ TO          | RESISTANCE                   | DVA (Connected) | DVA (Disconnected) |
|--------|------------------|------------------------------|-----------------|--------------------|
| Orange | Engine GND       | 1600-1800 (800-900 per coil) | 180-400 V       | 180-400 V (*)      |
| Brown  | White (or Brown) | 140-160                      | 0.5 V +         | 0.5 V + (#)        |

(\*) This reading can be used to determine if a stator or pack has a problem. For instance, if you have no spark

## **Mercury Troubleshooting**

on any cylinder and the stator's DVA reading is low – disconnect the stator wires and recheck the DVA output. If the reading stays low – the stator is bad. If the reading is now within spec – the pack is bad.

(#) This reading can be used to determine if a pack has a problem in the triggering circuit. For instance, if you have no spark on one cylinder and the trigger's DVA reading for that cylinder is low – disconnect the trigger wires and recheck the DVA output. If the reading stays low – the trigger is bad. If the reading is now within spec – the pack is bad.

6. Inspect the ignition coils. You should have either a Red, Orange or Green coil with a bare braided ground wire from the backside of the coil. This bare braided ground wire **MUST** be connected to a clean engine ground. You cannot use a Black or Blue ignition coil.
7. Check the ignition coils as follows: Check resistance from + to – terminal reading should be 0.2-1.0 ohms and 800-1100 ohms from the high tension lead to engine ground. There should be no connection from the – terminal to engine ground.
8. Check the center hub triggering magnet in the flywheel. A loose magnet can cause this problem.
9. Check the triggering and charge coil flywheel magnets for cracked, broken and loose magnets.

### **ENGINE HAS SPARK BUT WILL NOT RUN:**

1. Index the flywheel and check the timing. If it is out by 180 degrees, swap the trigger wires to the switch box.
2. If the timing is off by any other degree, check the flywheel key.

### **NO SPARK OR INTERMITTENT SPARK ON ONE CYLINDER:**

1. Check the DVA output between the Green and Green/White wires from the switch box, also between the Blue and Blue/White wires while they are connected to the ignition coils. You should have a reading of at least 150V or more. If the reading is low on one cylinder, disconnect the wires from the ignition coil for that cylinder and reconnect them to a load resistor. Retest. If the reading is now ok, the ignition coil is likely bad. A continued low reading indicates a bad switch box.
2. Connect an inductive tachometer to each cylinder and compare the RPM readings at the RPM where the problem is occurring. If only one cylinder is dropping out, swap the ignition coil locations and retest. If the problem follows a coil, replace the coil. If it stays on the same spark plug, replace the switch box.
3. Disconnect the negative side of the ignition coils. Connect a jumper wire to the negative side of the coil and while the engine is turning over, tap the jumper wire to engine ground. If this causes the coil to spark, the coil is good and you will need to replace the pack.
4. Check the triggering and charge coil flywheel magnets for cracked, broken and loose magnets.

### **SWITCH BOX OR TRIGGER REPEATEDLY BLOWS ON SAME CYLINDER:**

1. Check the trigger wires for shorts to engine ground as a shorted trigger wire can destroy a SCR inside the switch box.
2. In contrast, a shorted SCR inside the switch box can destroy a trigger coil. Check the trigger resistance and DVA output (see NO SPARK ON ANY CYLINDER above).
3. Replace the ignition coil on the cylinder dropping spark.

### **MISS AT ANY RPM:**

1. Disconnect the Yellow wires from the stator to the rectifier and retest. If the miss clears, replace the rectifier.
2. In the water or on a Dynameters, check the DVA output on the Green wires from the switch box while connected to the ignition coils. You should have a reading of at least 150V DVA or more, increasing with engine RPM until it reaches 300-400V DVA maximum. A sharp drop in DVA right before the miss becomes apparent on all cylinders will normally be caused by a bad stator. A sharp drop in DVA on less than all cylinders will normally be the switch box or trigger.
3. Connect an inductive tachometer to each cylinder in turn and try to isolate the problem. A high variance in RPM on one cylinder usually indicates a problem in the switch box or ignition coil. Occasionally a trigger will cause this same problem. Check the trigger DVA voltage (see NO SPARK ON ANY CYLINDER above).
4. Perform a high-speed shutdown and read the spark plugs. Check for water. A crack in the block can cause a miss at high speed when the water pressure gets high, but a normal shutdown will mask the problem.
5. Check the triggering and charge coil flywheel magnets for cracked, broken and loose magnets.
6. Rotate the stator one bolt hole in either direction and retest.

## Mercury Troubleshooting

### Two Cylinder Engines 1970-1971 Model 400 (With the 332-4172 Switch Box)

#### NO SPARK ON ANY CYLINDER:

1. Disconnect the Orange (or Salmon) stop wire AT THE SWITCH BOX and retest. If the engine's ignition now has spark, the stop circuit has a fault. Check the key switch, harness and shift switch.

2. Check the stator and trigger resistance and DVA output:

| WIRE           | READ TO    | OEM OHMS  | CDI OHMS  | DVA (Connected) | DVA (Disconnected) |
|----------------|------------|-----------|-----------|-----------------|--------------------|
| Blue           | Engine GND | 3200-3800 | 2200-2600 | 180-400 V       | 180-400 V (*)      |
| Red (or White) | Engine GND | 45-55     | 45-55     | 25-100 V        | 25-100 V (*)       |
| Brown          | Engine GND | N/A       | N/A       | 1.0 V +         | N/A                |

(\*) This reading can be used to determine if a stator or pack has a problem. For instance, if you have no spark on any cylinder and the stator's DVA reading is low – disconnect the stator wires and recheck the DVA output. If the reading stays low – the stator is bad. If the reading is now within spec – the pack is bad.

#### ENGINE HAS SPARK BUT WILL NOT RUN:

1. Index the flywheel and check the timing. If it is out, check the flywheel key.
2. If the timing is off and the flywheel key is ok, replace the trigger.

#### NO SPARK ON ONE CYLINDER:

If one cylinder is firing good and one is not, the problem is going to be either in the distributor cap or spark plug wire.

### Two Cylinder Engines 1974-1985 (With 114-4911/332-4911/332-4733 Switch Box)

#### NO SPARK ON ANY CYLINDER:

1. Disconnect the Orange (or Black/Yellow) stop wire AT THE SWITCH BOX and retest. If the engine's ignition now has spark, the stop circuit has a fault. Check the key switch, harness and shift switch.
2. Disconnect the Yellow wires from the stator to the rectifier and retest. If the engine sparks, replace the rectifier.
3. Check the cranking RPM. A low cranking speed may not allow the system to spark properly. This can be caused by a weak battery, dragging starter, bad battery cables or a mechanical problem inside the engine.
4. Inspect and clean all engine and ignition ground connections.
5. Check the stator and trigger resistance and DVA output:

| WIRE  | READ TO          | OEM RESISTANCE | CDI RESISTANCE | DVA (Connected) | DVA (Disconnected) | Blue |
|-------|------------------|----------------|----------------|-----------------|--------------------|------|
| White |                  | 6000-7400 (a)  | 2000-2500 (a)  | 180-400 V       | 180-400 V (*)      |      |
| Blue  | Engine GND       | 5200-7000 (b)  | 2200-2500 (b)  | 180-400 V       | 180-400 V (*)      |      |
| Red   | Blue             | 185-205 (a)    | 45-55 (a)      | 25-100 V        | 25-100 V (*)       |      |
| Red   | Engine GND       | 180-340 (b)    | 45-55 (b)      | 25-100 V        | 25-100 V (*)       |      |
| Brown | White (or Brown) | 800-1000 (a)   | 800-1000 (a)   | 0.5 V +         | 0.5 V + (#)        |      |
| Brown | White (or Brown) | 140-160 (b)    | 140-160 (b)    | 0.5 V +         | 0.5 V + (#)        |      |

(\*) This reading can be used to determine if a stator or pack has a problem. For instance, if you have no spark on any cylinder and the stator's DVA reading is low – disconnect the stator wires and recheck the DVA output. If the reading stays low – the stator is bad. If the reading is now within spec – the pack is bad.

(#) This reading can be used to determine if a pack has a problem in the triggering circuit. For instance, if you have no spark on one cylinder and the trigger's DVA reading for that cylinder is low – disconnect the trigger wires and recheck the DVA output. If the reading stays low – the trigger is bad. If the reading is now within spec – the pack is bad.

(a) 1973-1974

(b) 1976-1978 (w/ full ring stator CDI part# 174-5255)

6. Check the center hub triggering magnet in the flywheel. A loose magnet can cause this problem.
7. Check the triggering and charge coil flywheel magnets for cracked, broken and loose magnets.

#### ENGINE HAS SPARK BUT WILL NOT RUN:

1. Index the flywheel and check the timing. If it is out by 180 degrees, swap the trigger wires to the switch box.
2. If the timing is off by any other degree, check the flywheel key.



## Mercury Troubleshooting

### NO SPARK OR INTERMITTENT SPARK ON ONE CYLINDER:

1. Check the DVA output from the switch box on the Green wire while it is connected to the ignition coil. You should have a reading of at least 150V or more. If the reading is low, you can have a problem firing both cylinders (the one that is firing will usually show a weak spark).
2. Connect an inductive tachometer to each cylinder and compare the RPM readings at the RPM where the problem is occurring. If only one cylinder is dropping out, swap the ignition coil locations and retest. If the problem follows a coil, replace the coil. If it stays on the same spark plug, replace the switch box.
3. Check the triggering and charge coil flywheel magnets for cracked, broken and loose magnets.

### SWITCH BOX OR TRIGGER REPEATEDLY BLOWS ON SAME CYLINDER:

1. Check the trigger wires for shorts to engine ground as a shorted trigger wire can destroy a SCR inside the switch box.
2. In contrast, a shorted SCR inside the switch box can destroy a trigger coil. Check the trigger resistance and DVA output (see NO SPARK ON ANY CYLINDER above).
3. Replace the ignition coil on the cylinder dropping spark.

### ENGINE WILL NOT SHUT OFF:

Disconnect the stop wire at the switch box. Connect a jumper wire to the stop wire from the switch box and short it to engine ground. If this stops the switch box from sparking, the stop circuit has a fault. Check the key switch, harness and shift switch. If this does not stop the switch box from sparking, replace the switch box. Repeat test as necessary for additional switch boxes.

### MISS AT ANY RPM:

1. Disconnect the Yellow wires from the stator to the rectifier and retest. If the miss clears, replace the rectifier.
2. In the water or on a Dynamometer, check the DVA output on the Green wires from the switch box while connected to the ignition coils. You should have a reading of at least 150V DVA or more, increasing with engine RPM until it reaches 300-400V DVA maximum. A sharp drop in DVA right before the miss becomes apparent on all cylinders will normally be caused by a bad stator. A sharp drop in DVA on less than all cylinders will normally be the switch box or trigger.
3. Connect an inductive tachometer to each cylinder in turn and try to isolate the problem. A high variance in RPM on one cylinder usually indicates a problem in the switch box or ignition coil. Occasionally a trigger will cause this same problem. Check the trigger DVA voltage (see NO SPARK ON ANY CYLINDER above).
4. Perform a high-speed shutdown and read the spark plugs. Check for water. A crack in the block can cause a miss at high speed when the water pressure gets high, but a normal shutdown will mask the problem.
5. Check the triggering and charge coil flywheel magnets for cracked, broken and loose magnets.

## Two Cylinder Engines 1979-1996 (With 114-7452A3 & K1/339-7452 Switch Box)

### NO FIRE ON EITHER CYLINDER:

1. Disconnect the Black/Yellow Kill wire AT THE SWITCH BOX and retest. If the engine now has fire, the stop circuit has a fault. Check the key switch and harness.
2. Inspect and clean all engine and ignition ground connections.
3. Check the Stator and Trigger DVA/ resistance.

| WIRE         | READ TO     | OEM RESISTANCE | CDI RESISTANCE | DVA (Connected) | DVA (Disconnected) |
|--------------|-------------|----------------|----------------|-----------------|--------------------|
| Black/Yellow | Engine GND  | 3250-3800      | 2200-2750      | 180-400 V       | 180-400 V (*)      |
| Black/White  | Engine GND  | 150-250        | 200-250        | 25-100 V        | 25-100 V (*)       |
| Brown/Yellow | Brown/White | 650-850        | 700-800        | 4 V +           | 4 V + (#)          |
| Brown/Yellow | Engine GND  | Open           | Open           | 1 V +           | N/A                |
| Brown/White  | Engine GND  | Open           | Open           | 1 V +           | N/A                |

(\*) This reading can be used to determine if a stator or pack has a problem. For instance, if you have no spark on any cylinder and the stator's DVA reading is low – disconnect the stator wires and recheck the DVA output. If the reading stays low – the stator is bad. If the reading is now within spec – the pack is bad.

(#) This reading can be used to determine if a pack has a problem in the triggering circuit. For instance, if you have no spark on one cylinder and the trigger's DVA reading for that cylinder is low – disconnect the trigger wires and recheck the DVA output. If the reading stays low – the trigger is bad. If the reading is now within spec – the pack is bad.

4. Check the cranking RPM. A cranking speed of less than 250-RPM will not allow the system to spark properly. This can be caused by a weak battery, dragging starter, bad battery cables or a mechanical problem inside the

## Mercury Troubleshooting

engine.

5. Check the flywheel magnets for cracked, broken and loose magnets.

### NO SPARK OR INTERMITTENT SPARK ON ONE CYLINDER:

1. Check the flywheel magnets for cracked, broken and loose magnets.
2. Check the trigger resistance and DVA output:

| WIRE         | READ TO     | OEM RESISTANCE | CDI RESISTANCE | DVA (Connected) | DVA (Disconnected) |
|--------------|-------------|----------------|----------------|-----------------|--------------------|
| Brown/Yellow | Brown/White | 750-1400       | 700-800        | 4 V +           | 4 V + (#)          |
| Brown/Yellow | Engine GND  | Open           | Open           | 1 V +           | N/A                |
| Brown/White  | Engine GND  | Open           | Open           | 1 V +           | N/A                |

(#) This reading can be used to determine if a pack has a problem in the triggering circuit. For instance, if you have no spark on one cylinder and the trigger's DVA reading for that cylinder is low – disconnect the trigger wires and recheck the DVA output. If the reading stays low – the trigger is bad. If the reading is now within spec – the pack is bad.

3. Check the DVA output on the Green wires from the switch box while connected to the ignition coils. Check the reading on the switch box terminal AND on the ignition coil terminal. You should have a reading of at least 150V or more at both places. If the reading is low on one cylinder, disconnect the Green wire from the ignition coil for that cylinder and reconnect it to a load resistor. Retest. If the reading is now good, the ignition coil is likely bad. A continued low reading indicates a bad switch box.
4. Check the ignition coil's primary resistance from the Positive (+) Terminal to the Negative (-) Terminal. You should read 0.02-0.04 ohms.
5. Check the ignition coil's secondary resistance from the sparkplug wire to engine ground. You should read 800-1.1K ohms. If out of this range, replace the ignition coil.
6. Connect an inductive tachometer to each cylinder and compare the RPM readings at the RPM where the problem is occurring. If only one cylinder is dropping out, swap the ignition coil locations and retest. If the problem follows a coil, replace the coil. If it stays on the same spark plug, replace the switch box.

### SWITCH BOX OR TRIGGER REPEATEDLY BLOWS ON SAME CYLINDER:

1. Check the trigger wires for shorts to engine ground as a shorted trigger wire can destroy a SCR inside the switch box.
2. In contrast, a shorted SCR inside the switch box can destroy a trigger coil. Check the trigger resistance and DVA output (see NO SPARK OR INTERMITTENT SPARK ON ONE CYLINDER above).
3. Replace the ignition coil on the cylinder dropping spark.

### ENGINE WILL NOT SHUT OFF:

Disconnect the Black/Yellow stop wire at the switch box. Connect a jumper wire to the Black/Yellow stop terminal (or wire) from the switch box and short it to engine ground. If this stops the switch box from sparking, the stop circuit has a fault. Check the key switch and harness. If this does not stop the switch box from sparking, replace the switch box.

### WILL NOT ACCELERATE BEYOND 3000-4000 RPM:

1. Connect a DVA meter between the stator's Black/Yellow wire/terminal and engine ground. Run the engine up to the RPM where the problem is occurring. DVA voltage should increase with RPM. A sharp drop in DVA right before the problem occurs usually indicates a bad stator.
2. Connect a DVA meter between the stator's Black/White wire/terminal and engine ground. The DVA voltage should show a smooth climb in voltage and remain high through the RPM range. A reading lower than on the Black/Yellow wire/terminal reading indicates a bad stator.
3. Connect an inductive tachometer to each cylinder in turn and try to isolate the problem. A single cylinder dropping spark will likely be a bad switch box or ignition coil. All cylinders not sparking properly usually indicates a bad stator.
4. Perform a high-speed shutdown and read the spark plugs. Check for water. A crack in the block can cause a miss at high speed when the water pressure gets high, but a normal shutdown will mask the problem.
5. Check the flywheel magnets for cracked, broken and loose magnets.

### MISS AT ANY RPM:

1. Disconnect the Yellow wires from the stator to the rectifier and retest. If the miss clears, replace the rectifier.
2. In the water or on a Dynameters, check the DVA output on the Green wires from the switch box while connected

## Mercury Troubleshooting

to the ignition coils. You should have a reading of at least 150V DVA or more, increasing with engine RPM until it reaches 300-400V DVA maximum. A sharp drop in DVA right before the miss becomes apparent on all cylinders will normally be caused by a bad stator. A sharp drop in DVA on less than all cylinders will normally be the switch box or trigger.

3. Connect an inductive tachometer to each cylinder in turn and try to isolate the problem. A high variance in RPM on one cylinder usually indicates a problem in the switch box or ignition coil. Occasionally a trigger will cause this same problem. Check the trigger DVA voltage (see NO SPARK OR INTERMITTENT SPARK ON ONE CYLINDER above).
4. Perform a high-speed shutdown and read the spark plugs. Check for water. A crack in the block can cause a miss at high speed when the water pressure gets high, but a normal shutdown will mask the problem.
5. Check the flywheel magnets for cracked, broken and loose magnets.

### Two Cylinder Engines 1994-1996 (With 114-4952A30/18495A9, A14, A16, A20, A21 or A30 Switch Box)

(NOTE) This engine has a locked trigger arm. Therefore, the timing is controlled by the switch box and is adjusted according to the engine RPM. RPM limiting is done by retarding the timing at high RPM.

#### NO SPARK ON EITHER CYLINDER:

1. Visually inspect the stator for cracks or varnish leakage. If found, replace the stator.
2. Disconnect the Black/Yellow kill wire FROM THE SWITCHBOX. If spark returns, the Kill circuit has a fault.
3. Check for broken or bare wires on the switchbox (including ground wires, stator and trigger).
4. Check the stator and trigger as follows:

| Read from    | Read to           | OEM Ohms  | CDI Ohms    | DVA Connected | Disconnected      |
|--------------|-------------------|-----------|-------------|---------------|-------------------|
| Stator wire  | Black Stator wire | 2900-3500 | 2300-2750   | 180V or more  | Blue 180V or more |
| Stator wire  | Black Stator wire | 100-180   | 200-250     | 25 V or more  | Red 25 V or more  |
| Stator wire  | Engine Ground     | --        | --          | 5 V           | Black < 1 V       |
| White        |                   |           |             |               | Brown/            |
| Brown/Yellow | 650-750           | 650-750   | 4 V or more | 4 V or more   |                   |
| Brown/White  | Eng Gnd           | OPEN      | OPEN        | < 1 V         | < 1 V             |
| Brown/Yellow | Eng Gnd           | OPEN      | OPEN        | < 1 V         | < 1 V             |

#### NO SPARK OR INTERMITTANT SPARK ON ONE CYLINDER:

1. Inspect the flywheel to see if one of the magnets has broken loose and shifted around to where it is touching the other magnet.
2. Connect a spark tester to the ignition coils and swap the Green wires on the switchbox to the ignition coils. If the problem moves, check the trigger wires for continuity. If OK, replace the switchbox. If the problem did not move, replace the ignition coil.
3. Verify the correct spark plugs are installed. OEM calls for a BP8H-N-10 or BPZ8H-N-10 (use the BPZ8H-N-10 is the engine has a miss-fire).

#### ENGINE WILL NOT SHUT OFF:

Check the kill circuit in the pack by using a jumper wire connected to the Black/Yellow wire coming out of the pack and shorting it to ground. If this kills the engine, the kill circuit in the harness or on the boat is defective, possibly the ignition switch.

#### HIGH SPEED MISS:

1. Disconnect the Yellow wires to the rectifier/regulator and retest. If the miss is gone, replace the rectifier/regulator.
2. Check the DVA voltage of the stator from the Red wire to the Black wire while running the engine. It should show a smooth climb on the voltage. NOTICE: Use caution when doing this and do not exceed the rated voltage range of your meter. If there is a sudden or fast drop in voltage right before the miss becomes apparent, the stator is usually at fault.
3. Verify the correct spark plugs are installed. OEM calls for a BP8H-N-10 or BPZ8H-N-10. If the BP8H-N-10 spark plugs are installed, try the BPZ8H-N-10 spark plugs.
4. If there is no indication of the problem, it could be a small water leak in one or both cylinders.

#### BOTH CYLINDERS HAVE SPARK BUT THE ENGINE WILL NOT RUN:

1. Check the flywheel shear key.
2. Index the flywheel and check timing on both cylinders. If the timing is off, check the trigger and flywheel. NOTE: If one of the trigger wires is shorted, the timing may not advance on ONE cylinder, but the other cylinder will advance.
3. If no other fault is found, replace the switch box.

## **Mercury Troubleshooting**

### **ENGINE LOW ON POWER OR TIMING WILL NOT ADVANCE WITH ENGINE RPM:**

1. Verify the ignition timing is advancing from about 5 degrees BTDC at idle to approximately 28 degrees BTDC at 3000 RPM. NOTE: The timing will retard slightly from 28 degrees BTDC at 3000 RPM to 25 degrees BTDC at 5500 RPM, dropping down to 15 Degrees BTDC between 5800 to 6200 RPM.
2. Index the flywheel and check timing on both cylinders. If the timing is off, check the trigger and flywheel. NOTE: If one of the trigger wires is shorted, the timing may not advance on ONE cylinder, but the other cylinder will advance.

### **SWITCH BOX OR TRIGGER REPEATEDLY BLOWS ON SAME CYLINDER:**

1. Check the trigger wires for shorts to engine ground as a shorted trigger wire can destroy a SCR inside the switch box.
2. In contrast, a shorted SCR inside the switch box can destroy a trigger coil. Check the trigger resistance and DVA output (see NO SPARK OR INTERMITTENT SPARK ON ONE CYLINDER above).
3. Replace the ignition coil on the cylinder dropping spark.

### **WILL NOT ACCELERATE BEYOND 3000-4000 RPM:**

1. Disconnect the Yellow wires from the stator to the rectifier and retest. If the engine now has good spark, replace the rectifier.
2. Connect a DVA meter between the stator's Blue and Black wires. Run the engine up to the RPM where the problem is occurring. DVA voltage should increase with RPM. A sharp drop in DVA right before the problem occurs usually indicates a bad stator.
3. Connect a DVA meter between the stator's Red and Black wires. The DVA voltage should show a smooth climb in voltage and remain high through the RPM range. A reading lower than on the Blue wire reading indicates a bad stator.
4. Connect an inductive tachometer to each cylinder in turn and try to isolate the problem. A single cylinder dropping spark will likely be a bad switch box or ignition coil. All cylinders not sparking properly usually indicates a bad stator.
5. Perform a high-speed shutdown and read the spark plugs. Check for water. A crack in the block can cause a miss at high speed when the water pressure gets high, but a normal shutdown will mask the problem.
6. Check the triggering and charge coil flywheel magnets for cracked, broken and loose magnets.

### **MISS AT ANY RPM:**

1. Disconnect the Yellow wires from the stator to the rectifier and retest. If the miss clears, replace the rectifier.
2. In the water or on a Dynameters, check the DVA output on the Green wires from the switch box while connected to the ignition coils. You should have a reading of at least 150V DVA or more, increasing with engine RPM until it reaches 300-400V DVA maximum. A sharp drop in DVA right before the miss becomes apparent on all cylinders will normally be caused by a bad stator. A sharp drop in DVA on less than all cylinders will normally be the switch box or trigger.
3. Connect an inductive tachometer to each cylinder in turn and try to isolate the problem. A high variance in RPM on one cylinder usually indicates a problem in the switch box or ignition coil. Occasionally a trigger will cause this same problem. Check the trigger DVA voltage (see NO SPARK OR INTERMITTENT SPARK ON ONE CYLINDER above).
4. Perform a high-speed shutdown and read the spark plugs. Check for water. A crack in the block can cause a miss at high speed when the water pressure gets high, but a normal shutdown will mask the problem.
5. Check the triggering and charge coil flywheel magnets for cracked, broken and loose magnets.

## **Two Cylinder Engines 1994-2006 (With 114-5713/855713A3 & A4 Switch Box)**

### **NO SPARK ON ANY CYLINDER:**

1. Disconnect the Black/Yellow stop wire AT THE SWITCH BOX and retest. If the engine's ignition now has spark, the stop circuit has a fault. Check the key switch, harness and shift switch.
2. Check the cranking RPM. A cranking speed of less than 250-RPM will not allow the system to spark properly. This can be caused by a weak battery, dragging starter, bad battery cables or a mechanical problem inside the engine.
3. Inspect and clean all engine and ignition ground connections.

## Mercury Troubleshooting

4. Check the stator resistance and DVA output as given below:

| WIRE        | READ TO     | OEM OHMS | CDI OHMS | DVA (Connected) | DVA (Disconnected) |
|-------------|-------------|----------|----------|-----------------|--------------------|
| White/Green | Green/White | 370-445  | 306-420  | 150-400 V       | 200-400 V (*)      |

(\*) This reading can be used to determine if a stator or pack has a problem. For instance, if you have no spark on any cylinder and the stator's DVA reading is low – disconnect the stator wires and recheck the DVA output. If the reading stays low – the stator is bad. If the reading is now within spec – the pack is bad.

5. Check the triggering and charge coil flywheel magnets for cracked, broken and loose magnets.

### NO SPARK OR INTERMITTENT SPARK ON ONE CYLINDER:

1. Check the trigger resistance and DVA output as shown below:

| WIRE         | READ TO     | OEM OHMS | CDI OHMS | DVA (Connected) | DVA (Disconnected) |
|--------------|-------------|----------|----------|-----------------|--------------------|
| Brown/Yellow | Brown/White | 650-850  | 800-1100 | 4 V +           | 4 V + (#)          |
| Brown/Yellow | Engine GND  | Open     | Open     | 1 V +           | N/A                |
| Brown/White  | Engine GND  | Open     | Open     | 1 V +           | N/A                |

(#) This reading can be used to determine if a pack has a problem in the triggering circuit. For instance, if you have no spark on one cylinder and the trigger's DVA reading for that cylinder is low – disconnect the trigger wires and recheck the DVA output. If the reading stays low – the trigger is bad. If the reading is now within spec – the pack is bad.

2. Check the DVA output on the Green wires from the switch box while connected to the ignition coils. Check the reading on the switch box terminal AND on the ignition coil terminal. You should have a reading of at least 150V or more at both places. If the reading is low on one cylinder, disconnect the Green wire from the ignition coil for that cylinder and reconnect it to a load resistor. Retest. If the reading is now good, the ignition coil is likely bad. A continued low reading indicates a bad power pack.
3. If the cylinders are only misfiring above an idle, connect an inductive tachometer to each cylinder in turn and try to isolate the problem cylinder.
4. Check the triggering and charge coil flywheel magnets for cracked, broken and loose magnets.

### SWITCH BOX OR TRIGGER REPEATEDLY BLOWS ON SAME CYLINDER:

1. Check the trigger wires for shorts to engine ground as a shorted trigger wire can destroy a SCR inside the switch box.
2. In contrast, a shorted SCR inside the switch box can destroy a trigger coil. Check the trigger resistance and DVA output (see NO SPARK OR INTERMITTENT SPARK ON ONE CYLINDER above).
3. Replace the ignition coil on the cylinder dropping spark.

### ENGINE WILL NOT SHUT OFF:

Disconnect the stop wire at the switch box. Connect a jumper wire to the stop wire from the switch box and short it to engine ground. If this stops the switch box from sparking, the stop circuit has a fault. Check the key switch, harness and shift switch. If this does not stop the switch box from sparking, replace the switch box. Repeat test as necessary for additional switch boxes.

### WILL NOT ACCELERATE BEYOND 3000-4000 RPM:

1. Connect a DVA meter between the stator's Green/White and White/Green wires. Run the engine up to the RPM where the problem is occurring. DVA voltage should increase with RPM. A sharp drop in DVA right before the problem occurs usually indicates a bad stator.
2. Connect an inductive tachometer to each cylinder in turn and try to isolate the problem. A single cylinder dropping spark will likely be a bad switch box or ignition coil. All cylinders not sparking properly usually indicates a bad stator.
3. Perform a high-speed shutdown and read the spark plugs. Check for water. A crack in the block can cause a miss at high speed when the water pressure gets high, but a normal shutdown will mask the problem.
4. Check the triggering and charge coil flywheel magnets for cracked, broken and loose magnets.



# Mercury Troubleshooting

## MISS AT ANY RPM:

1. In the water or on a Dynameters, check the DVA output on the Green wires from the switch box while connected to the ignition coils. You should have a reading of at least 150V DVA or more, increasing with engine RPM until it reaches 300-400V DVA maximum. A sharp drop in DVA right before the miss becomes apparent on all cylinders will normally be caused by a bad stator. A sharp drop in DVA on less than all cylinders will normally be the switch box or trigger.
2. Connect an inductive tachometer to each cylinder in turn and try to isolate the problem. A high variance in RPM on one cylinder usually indicates a problem in the switch box or ignition coil. Occasionally a trigger will cause this same problem. Check the trigger DVA voltage (see NO SPARK OR INTERMITTENT SPARK ON ONE CYLINDER above).
3. Perform a high-speed shutdown and read the spark plugs. Check for water. A crack in the block can cause a miss at high speed when the water pressure gets high, but a normal shutdown will mask the problem.
4. Check the triggering and charge coil flywheel magnets for cracked, broken and loose magnets.

## Three Cylinder Engines 1976-1996

### Three Cylinder Engines Using a Single Switch Box and Three Ignition Coils

#### NO SPARK ON ANY CYLINDER:

1. Disconnect the Black/Yellow (or Orange) stop wire AT THE SWITCH BOX and retest. If the engine's ignition now has spark, the stop circuit has a fault. Check the key switch, harness and shift switch.
2. Disconnect the Yellow wires from the stator to the rectifier and retest. If the engine has spark, replace the rectifier.
3. Check the cranking RPM. A low cranking speed may not allow the system to spark properly. This can be caused by a weak battery, dragging starter, bad battery cables or a mechanical problem inside the engine.
4. Inspect and clean all engine and ignition ground connections.
5. Check the stator resistance and DVA output as given below:

#### Black Stator using Flywheel with Bolted-in Magnets

| WIRE | READ TO    | OEM OHMS  | CDI OHMS  | DVA (Connected) | DVA (Disconnected) |
|------|------------|-----------|-----------|-----------------|--------------------|
| Blue | Engine GND | 5800-7000 | 2000-2400 | 180-400 V       | 180-400 V (*)      |
| Red  | Engine GND | 135-165   | 45-55     | 25-100 V        | 25-100 V (*)       |

#### Black Stator using Flywheel with Glued-in Magnets

| WIRE | READ TO    | OEM OHMS  | CDI OHMS | DVA (Connected) | DVA (Disconnected) |
|------|------------|-----------|----------|-----------------|--------------------|
| Blue | Engine GND | 3250-3650 | 488-662  | 180-400 V       | 180-400 V (*)      |
| Red  | Engine GND | 75-90     | 28-32    | 25-100 V        | 25-100 V (*)       |

#### Red Stator Kit

| WIRE        | READ TO     | OEM OHMS | CDI OHMS | DVA (Connected) | DVA (Disconnected) |
|-------------|-------------|----------|----------|-----------------|--------------------|
| White/Green | Green/White | 500-700  | 400-550  | 180-400 V       | 180-400 V (*)      |
| Blue        | Engine GND  | OPEN     | OPEN     | 180-400 V       | 180-400 V (*)      |

(\*) This reading can be used to determine if a stator or pack has a problem. For instance, if you have no spark on any cylinder and the stator's DVA reading is low – disconnect the stator wires and recheck the DVA output. If the reading stays low – the stator is bad. If the reading is now within spec – the pack is bad.

6. Check the center hub triggering magnet in the flywheel. A loose magnet can cause this problem.
7. Check the triggering and charge coil flywheel magnets for cracked, broken and loose magnets.

#### NO SPARK OR INTERMITTENT SPARK ON ONE OR MORE CYLINDERS:

1. Check the trigger resistance and DVA output as given below:

| WIRE   | READ TO                | RESISTANCE | DVA (Connected) | DVA (Disconnected) |
|--------|------------------------|------------|-----------------|--------------------|
| Brown  | White/Black (or Black) | 800-1400   | 4 V +           | 4 V + (#)          |
| White  | White/Black (or Black) | 800-1400   | 4 V +           | 4 V + (#)          |
| Purple | White/Black (or Black) | 800-1400   | 4 V +           | 4 V + (#)          |
| Brown  | Engine GND             | Open       | 1 V +           | N/A                |
| White  | Engine GND             | Open       | 1 V +           | N/A                |
| Purple | Engine GND             | Open       | 1 V +           | N/A                |

## **Mercury Troubleshooting**

- (#) This reading can be used to determine if a pack has a problem in the triggering circuit. For instance, if you have no spark on one cylinder and the trigger's DVA reading for that cylinder is low – disconnect the trigger wires and recheck the DVA output. If the reading stays low – the trigger is bad. If the reading is now within spec – the pack is bad.
2. Check the DVA output on the Green wires from the switch box while connected to the ignition coils. Check the reading on the switch box terminal AND on the ignition coil terminal. You should have a reading of at least 150V or more at both terminals. If the reading is low on one cylinder, disconnect the Green wire from the ignition coil for that cylinder and reconnect it to a load resistor. Retest. If the reading is now good, the ignition coil is likely bad. A continued low reading symptom indicates a bad power pack.
  3. If the cylinders are only misfiring above an idle, connect an inductive tachometer to all cylinders and try to isolate the problem cylinders.
  4. Swap the wires on the switchbox as shown below. If the miss or no fire problem moves to another cylinder, replace the switchbox. If it stays on the same cylinder(s), re-test the trigger and check the ignition coils ferrite core for cracks or broken cores (dismount the coils and carefully slide the coils out of the holder to expose the rubber boot covering the side opposite end of the coil from the sparkplug wire. If the dark grey ferrite core is damaged, replace the coil.  
Green Coil Wire with the Green/Red Coil Wire  
Swap the Purple Trigger Wire with the Brown Trigger Wire
  5. Check the triggering and charge coil flywheel magnets for cracked, broken and loose magnets.

### **SWITCH BOX OR TRIGGER REPEATEDLY BLOWS ON SAME CYLINDER:**

1. Check the trigger wires for shorts to engine ground as a shorted trigger wire can destroy a SCR inside the switch box.
2. In contrast, a shorted SCR inside the switch box can destroy a trigger coil. Check the trigger resistance and DVA output (see NO SPARK OR INTERMITTENT SPARK ON ONE OR MORE CYLINDERS above).
3. Replace the ignition coil on the cylinder dropping spark.

### **ENGINE WILL NOT SHUT OFF:**

Disconnect the stop wire at the switch box. Connect a jumper wire to the stop wire from the switch box and short it to engine ground. If this stops the switch box from sparking, the stop circuit has a fault. Check the key switch, harness and shift switch. If this does not stop the switch box from sparking, replace the switch box. Repeat test as necessary for additional switch boxes.

### **WILL NOT ACCELERATE BEYOND 3000-4000 RPM:**

1. Disconnect the Yellow wires from the stator to the rectifier and retest. If the engine now has good spark, replace the rectifier.
2. Connect a DVA meter between the stator's Blue wire and engine ground. Run the engine up to the RPM where the problem is occurring. DVA voltage should increase with RPM. A sharp drop in DVA right before the problem occurs usually indicates a bad stator. (Read from Blue to engine ground if the engine has a Red stator kit installed).
3. Connect a DVA meter between the stator's Red wire and engine ground. The DVA voltage should show a smooth climb in voltage and remain high through the RPM range. A reading lower than on the Blue wire reading indicates a bad stator.
4. Connect an inductive tachometer to each cylinder in turn and try to isolate the problem. A single cylinder dropping spark will likely be a bad switch box or ignition coil. All cylinders not sparking properly usually indicates a bad stator.
5. Perform a high-speed shutdown and read the spark plugs. Check for water. A crack in the block can cause a miss at high speed when the water pressure gets high, but a normal shutdown will mask the problem.
6. Check the triggering and charge coil flywheel magnets for cracked, broken and loose magnets.

### **MISS AT ANY RPM:**

1. Disconnect the Yellow wires from the stator to the rectifier and retest. If the miss clears, replace the rectifier.
2. In the water or on a Dynameters, check the DVA output on the Green wires from the switch box while connected to the ignition coils. You should have a reading of at least 150V DVA or more, increasing with engine RPM until it reaches 300-400V DVA maximum. A sharp drop in DVA right before the miss becomes apparent on all cylinders will normally be caused by a bad stator. A sharp drop in DVA on less than all cylinders will normally be the switch box or trigger.

## **Mercury Troubleshooting**

3. Connect an inductive tachometer to each cylinder in turn and try to isolate the problem. A high variance in RPM on one cylinder usually indicates a problem in the switch box or ignition coil. Occasionally a trigger will cause this same problem. Check the trigger DVA voltage (see NO SPARK OR INTERMITTENT SPARK ON ONE OR MORE CYLINDERS above).
4. Perform a high-speed shutdown and read the spark plugs. Check for water. A crack in the block can cause a miss at high speed when the water pressure gets high, but a normal shutdown will mask the problem.
5. Check the triggering and charge coil flywheel magnets for cracked, broken and loose magnets.
6. Rotate the stator one bolt hole in either direction and retest.

### **WILL NOT IDLE BELOW 1500 RPM:**

1. Check the Bias resistance from the Black/White terminal to engine ground. Reading should be 14-15,000 ohms.
2. Check the Stator and Trigger as described under “No Fire on Any Cylinder”.
3. Check for air leaks.

### **Four Cylinder Engines 1978-1998**

#### **Four Cylinder Engines Using a Single Switch Box and Four Ignition Coils**

#### **NO SPARK ON ANY CYLINDER:**

1. Disconnect the Black/Yellow (or Orange) stop wire AT THE SWITCH BOX and retest. If the engine’s ignition now has spark, the stop circuit has a fault. Check the key switch, harness and shift switch.
2. Disconnect the Yellow wires from the stator to the rectifier and retest. If the engine now has spark, replace the rectifier.
3. Check the cranking RPM. A cranking speed of less than 250-RPM will not allow the system to spark properly. This can be caused by a weak battery, dragging starter, bad battery cables or a mechanical problem inside the engine.
4. Inspect and clean all engine and ignition ground connections.
5. Verify the correct flywheel is installed.
6. Check the stator resistance and DVA output as shown below:

#### **Black Stator using Flywheel with Bolted-in Magnets**

| WIRE | READ TO    | OEM RESISTANCE | CDI RESISTANCE | DVA (Connected) | DVA (Disconnected) |
|------|------------|----------------|----------------|-----------------|--------------------|
| Blue | Blue/White | 5000-7000      | 2000-2400      | 180-400 V       | 180-400 V (*)      |
| Red  | Red/White  | 125-155        | 45-55          | 25-100 V        | 25-100 V (*)       |

#### **Black Stator using Flywheel with Glued-in Magnets**

| WIRE | READ TO    | OEM RESISTANCE | CDI RESISTANCE | DVA (Connected) | DVA (Disconnected) |
|------|------------|----------------|----------------|-----------------|--------------------|
| Blue | Blue/White | 3250-3650      | 488-662        | 180-400 V       | 180-400 V (*)      |
| Red  | Red/White  | 75-90          | 28-32          | 25-100 V        | 25-100 V (*)       |

#### **Red Stator Kit**

| WIRE        | READ TO     | OEM RESISTANCE | CDI RESISTANCE | DVA (Connected) | DVA (Disconnected) |
|-------------|-------------|----------------|----------------|-----------------|--------------------|
| White/Green | Green/White | 500-700        | 400-550        | 180-400 V       | 180-400 V (*)      |
| Blue        | Blue/White  | OPEN           | OPEN           | 180-400 V       | 180-400 V (*)      |

(\*) This reading can be used to determine if a stator or pack has a problem. For instance, if you have no spark on any cylinder and the stator’s DVA reading is low – disconnect the stator wires and recheck the DVA output. If the reading stays low – the stator is bad. If the reading is now within spec – the pack is bad.

7. Check the center hub triggering magnet in the flywheel. A loose magnet can cause this problem.
8. Check the triggering and charge coil flywheel magnets for cracked, broken and loose magnets.

## Mercury Troubleshooting

### NO SPARK OR INTERMITTENT SPARK ON ONE OR MORE CYLINDERS:

1. Check the trigger resistance and DVA output as given below:

| WIRE        | READ TO                | RESISTANCE | DVA (Connected) | DVA (Disconnected) |
|-------------|------------------------|------------|-----------------|--------------------|
| Purple      | White                  | 800-1400   | 4 V +           | 4 V + (#)          |
| Brown       | White/Black (or Black) | 800-1400   | 4 V +           | 4 V + (#)          |
| Purple      | Engine GND             | Open       | 1 V +           | N/A                |
| White       | Engine GND             | Open       | 1 V +           | N/A                |
| Brown       | Engine GND             | Open       | 1 V +           | N/A                |
| White/Black | Engine GND             | Open       | 1 V +           | N/A                |

(#) This reading can be used to determine if a pack has a problem in the triggering circuit. For instance, if you have no spark on one or two cylinders and the trigger's DVA reading for that cylinder is low – disconnect the trigger wires and recheck the DVA output. If the reading stays low – the trigger is bad. If the reading is now within spec – the pack is bad.

(Note) If #1 and #2, or #3 and #4 are misfiring, check the trigger as described above. The trigger has two coils firing four cylinders. #1 & 2 share a trigger coil and #3 & 4 share a trigger coil. Also, the switch box is divided into two parts. The #1 and #2 cylinders spark on one side and #3 and #4 spark from the other side of the switch box. If the trigger tests are okay according to the chart above, but you have two cylinders not firing (either #1 and #2, or #3 and #4), the switch box or stator is bad.

2. If you have two cylinders not firing (either #1 and #2, or #3 and #4), switch the stator leads end to end on the switch box (swap Red with Red/White) and (swap Blue with Blue/White). If the problem moves to the other cylinders, the stator is bad. If the problem stays on the same cylinders, the switch box is likely bad.
3. Check the DVA output on the Green wires from the switch box while connected to the ignition coils. Check the reading on the switch box terminal AND on the ignition coil terminal. You should have a reading of at least 150V or more at both terminals. If the reading is low on one cylinder, disconnect the Green wire from the ignition coil for that cylinder and reconnect it to a load resistor. Retest. If the reading is now good, the ignition coil is likely bad. A continued low reading symptom indicates a bad power pack.
4. If the cylinders are only misfiring above an idle, connect an inductive tachometer to all cylinders and try to isolate the problem cylinders.
5. Check the triggering and charge coil flywheel magnets for cracked, broken and loose magnets.

### SWITCH BOX OR TRIGGER REPEATEDLY BLOWS ON SAME CYLINDER:

1. Check the trigger wires for shorts to engine ground as a shorted trigger wire can destroy a SCR inside the switch box.
2. In contrast, a shorted SCR inside the switch box can destroy a trigger coil. Check the trigger resistance and DVA output (see NO SPARK OR INTERMITTENT SPARK ON ONE OR MORE CYLINDERS above).
3. Replace the ignition coil on the cylinder dropping spark.

### ENGINE WILL NOT SHUT OFF:

Disconnect the stop wire at the switch box. Connect a jumper wire to the stop wire from the switch box and short it to engine ground. If this stops the switch box from sparking, the stop circuit has a fault. Check the key switch, harness and shift switch. If this does not stop the switch box from sparking, replace the switch box. Repeat test as necessary for additional switch boxes.

### WILL NOT ACCELERATE BEYOND 3000-4000 RPM:

1. Disconnect the Yellow wires from the stator to the rectifier and retest. If the engine now has good spark, replace the rectifier.
2. Connect a DVA meter between the stator's Blue and Blue/White wires. Run the engine up to the RPM where the problem is occurring. DVA voltage should increase with RPM. A sharp drop in DVA right before the problem occurs usually indicates a bad stator. (Read from Blue to engine ground if the engine has a Red stator kit installed).
3. Connect a DVA meter between the stator's Red and Red/White wires. The DVA voltage should show a smooth climb in voltage and remain high through the RPM range. A reading lower than on the Blue wire reading indicates a bad stator.
4. Connect an inductive tachometer to each cylinder in turn and try to isolate the problem. A single cylinder dropping spark will likely be a bad switch box or ignition coil. All cylinders not sparking properly usually indicates a bad stator.
5. Perform a high-speed shutdown and read the spark plugs. Check for water. A crack in the block can cause a

## **Mercury Troubleshooting**

miss at high speed when the water pressure gets high, but a normal shutdown will mask the problem.

6. Check the triggering and charge coil flywheel magnets for cracked, broken and loose magnets.

### **MISS AT ANY RPM:**

1. Disconnect the Yellow wires from the stator to the rectifier and retest. If the miss clears, replace the rectifier.
2. In the water or on a Dynameters, check the DVA output on the Green wires from the switch box while connected to the ignition coils. You should have a reading of at least 150V DVA or more, increasing with engine RPM until it reaches 300-400V DVA maximum. A sharp drop in DVA right before the miss becomes apparent on all cylinders will normally be caused by a bad stator. A sharp drop in DVA on less than all cylinders will normally be the switch box or trigger.
3. Connect an inductive tachometer to each cylinder in turn and try to isolate the problem. A high variance in RPM on one cylinder usually indicates a problem in the switch box or ignition coil. Occasionally a trigger will cause this same problem. Check the trigger DVA voltage (see NO SPARK OR INTERMITTENT SPARK ON ONE OR MORE CYLINDERS above).
4. Perform a high-speed shutdown and read the spark plugs. Check for water. A crack in the block can cause a miss at high speed when the water pressure gets high, but a normal shutdown will mask the problem.
5. Check the triggering and charge coil flywheel magnets for cracked, broken and loose magnets.
6. Rotate the stator one bolt hole in either direction and retest.

### **WILL NOT IDLE BELOW 1500 RPM:**

1. Index the flywheel and check the timing on all cylinders. If the timing cannot be adjusted correctly or if the timing is off on one cylinder, replace the trigger.
2. Check for air leaks.
3. Check synchronization of the carburetors.

## **Six Cylinder Engines**

**1978-1999**

### **Inline 6 and V6 Carbureted Engines Using Dual Switch Boxes and Six Ignition Coils**

(SERVICE NOTE) Whenever replacing one switch box, consider replacing the other switchbox as well. Replacing just one switch box can result in damage to the engine if the remaining switch box on the engine has a problem in the bias circuit. A rule of thumb is if one cylinder does not fire due to the switchbox, replace one pack. Two or more cylinders, replace both switchboxes.

### **9 and 16 Amp Battery Charging Systems**

#### **NO FIRE ON ANY CYLINDER:**

1. Disconnect the Black/Yellow kill wire FROM BOTH PACKS.
2. Check for broken or bare wires on the unit, stator and trigger.
3. Check the resistance and DVA voltage of the stator as follows:

| READ FROM  | READ TO | OEM RESISTANCE | CDI RESISTANCE | DVA          |
|------------|---------|----------------|----------------|--------------|
| Blue       | Eng Gnd | 5000-7000      | 2000-2400*     | 180V or more |
| Blue/White | Eng Gnd | 5000-7000      | 2000-2400*     | 180V or more |
| Red        | Eng Gnd | 90-200         | 27-55*         | 20V or more  |
| Red/White  | Eng Gnd | 90-200         | 27-55*         | 20V or more  |



## Mercury Troubleshooting

4. Check the trigger as follows:

| BLACK SLEEVE | TO          | YELLOW SLEEVE TO | Resistance | DVA Reading          |
|--------------|-------------|------------------|------------|----------------------|
| Brown wire   | White wire  |                  | 800-1400   | 4V or more Connected |
| White wire   | Purple wire |                  | 800-1400   | 4V or more Connected |
| Purple wire  | Brown wire  |                  | 800-1400   | 4V or more Connected |
| Brown wire   | -           | Engine Ground    | Open       | 1V or more Connected |
| White wire   | -           | Engine Ground    | Open       | 1V or more Connected |
| Purple wire  | -           | Engine Ground    | Open       | 1V or more Connected |
| -            | Brown wire  | Engine Ground    | Open       | 1V or more Connected |
| -            | White wire  | Engine Ground    | Open       | 1V or more Connected |
| -            | Purple wire | Engine Ground    | Open       | 1V or more Connected |

\*\* Verify the resistance readings are in the same ballpark. i.e. If one coil reads 1200 ohms and the other reads 1500, the trigger is likely defective.

5. Disconnect the rectifier. If the engine has fire, replace the rectifier.

### NO SPARK ON ONE BANK (ODD OR EVEN CYLINDERS ON INLINE 6 CYLINDER):

1. Check the resistance and DVA voltage of the stator as follows:

| READ FROM  | READ TO | OEM RESISTANCE | CDI RESISTANCE | DVA          |
|------------|---------|----------------|----------------|--------------|
| Blue       | Eng Gnd | 5000-7000      | 2000-2400*     | 180V or more |
| Blue/White | Eng Gnd | 5000-7000      | 2000-2400*     | 180V or more |
| Red        | Eng Gnd | 90-200         | 27-55*         | 20V or more  |
| Red/White  | Eng Gnd | 90-200         | 27-55*         | 20V or more  |

\* Verify the resistance readings are in the same ballpark. i.e. If one coil reads 30 ohms and the other reads 50, the stator is likely defective.

- Swap both sets of the stator wires between the packs. If the problem moves, replace the stator.
- If the problem stays on the same bank, swap physical location and all connections of the two packs. If the problem stays with one pack, replace the pack. NOTE: If the pack is bad, it is recommended that BOTH packs be replaced AS A SET.

### INTERMITTANT SPARK ON ONE OR MORE CYLINDERS:

- Disconnect the white/black wire between the packs on a 6 cylinder and retest. If all cylinders now fire, replace both packs as there is a problem in the bias circuitry.
- On all others, check for low voltage from the stator and trigger. Disconnect the rectifier and retest. If the problem disappears, replace the rectifier.
- Check the trigger as follows:

| BLACK SLEEVE TO | YELLOW SLEEVE TO | Resistance    | DVA Reading          |
|-----------------|------------------|---------------|----------------------|
| Brown wire      | White wire       | 800-1400      | 4V or more Connected |
| White wire      | Purple wire      | 800-1400      | 4V or more Connected |
| Purple wire     | Brown wire       | 800-1400      | 4V or more Connected |
| Brown wire      | -                | Engine Ground | Open                 |
| White wire      | -                | Engine Ground | Open                 |
| Purple wire     | -                | Engine Ground | Open                 |
| -               | Brown wire       | Engine Ground | Open                 |
| -               | White wire       | Engine Ground | Open                 |
| -               | Purple wire      | Engine Ground | Open                 |

### ENGINE WILL NOT STOP RUNNING:

Connect a jumper wire to the Black/Yellow terminal or wire coming out of the pack and short it to ground. If this kills the engine, the kill circuit in the harness or on the boat is bad, possibly the ignition switch.

### HIGH SPEED MISS OR WEAK HOLE SHOT:

- Disconnect the rectifier and retest. If miss is gone, the rectifier is usually at fault. Remember a problem rectifier can damage a stator.
- DVA check the Blue and Blue/White wires to engine ground and do a running test. The voltage should show a smooth climb and stabilize, gradually falling off at higher RPM's (above 3000). If you see a sudden drop in

## **Mercury Troubleshooting**

voltage right before the miss becomes apparent, the stator is likely at fault.

3. Check DVA voltage on the Red wires reference to engine ground of the stator at high speed. NOTICE: Use caution when doing this and do not exceed the rated voltage range of your meter. The readings should show a smooth climb in voltage. If there is a sudden or fast drop in voltage right before the miss becomes apparent, the stator is usually at fault. If there is no indication of the problem, it could be mechanical problem.
4. Rotate the stator one bolt hole in either direction and re-test. If the miss is gone, leave the stator as is. If the miss is worse, rotate the stator back where it was.
5. Using extreme caution, on the water or connected to a dyno, take the engine to the RPM where the problem is occurring and hold it for a few seconds, then perform a high speed shutdown at that RPM. Check the sparkplugs for differences in color or the presence of water droplets on the sparkplug (an indicator of a possible crack in the engine block).

### **NO SPARK WITH THE SPARKPLUGS INSTALLED:**

1. Check for dragging starter or low battery causing slow cranking speed. DVA test stator and trigger.
2. Disconnect rectifier, regulator and retest. If the problem goes away, replace the rectifier and/or regulator.

### **SPARK ON ALL CYLINDERS BUT ENGINE WILL NOT RUN:**

Disconnect the White/Black wire and check the bias circuit (White/Black terminals) resistance to engine ground. Readings should be approximately 15,000Ω for standard packs. If the readings are correct on the packs, index the flywheel and check timing on all individual cylinders. If the timing varies, replace BOTH packs.

### **DESTROYED ONE OR TWO CYLINDERS/PISTONS:**

1. Check Bias resistance, from the White/Black stud to engine ground, you should read 13,000-15,000 ohms. Readings above 15,000 ohms or less than 13,000 ohms indicate a defective switchbox. Due to the design of the switchboxes, a switchbox with a defective bias circuit will damage a mating switchbox (domino effect). **REPLACE BOTH SWITCHBOXES AS A SET!!!!**
2. Use an ANALOG DC Voltmeter to check the voltage on the White/Black (Bias) terminal. With everything connected, run the engine at various Rpm's and watch the voltage reading. It should remain steady for a set RPM. Fluctuation in voltage indicates a problem in the bias circuit. If there is a problem, disconnect everything on the White/Black terminal except the jumper from the inside switchbox to the outside switchbox. Retest, if the problem persists, replace BOTH switch boxes. If the problem went away, reconnect the items taken off of the White/Black terminal one at a time, retest after every reconnection until you locate the source of the problem.

### **OVER-CHARGING THE BATTERY:**

1. Verify the cranking battery is not an AGM, Maintenance free or Gel Cell battery. It needs to be a traditional flooded cell battery.
2. Verify the regulator has not been removed from the engine. If so, replace the rectifier with a regulator/rectifier.
3. Swap the battery with a known good one. If no change, check the resistance of the Yellow wires to engine ground. It should read open. A short on one wire can cause over-charging.

#### **40 Amp Battery Charging Systems**

| WIRE       | READ TO    | OEM RESISTANCE | CDI RESISTANCE | DVA (Connected) | DVA (Disconnected) |
|------------|------------|----------------|----------------|-----------------|--------------------|
| Blue       | Engine GND | 3200-4200      | 2100-2400      | 180-400 V       | 180-400 V (*)      |
| Blue/White | Engine GND | 3200-4200      | 2100-2400      | 180-400 V       | 80-400 V (*)       |
| Red Engine | GND        | 90-140         | 28-32          | 25-100 V        | 25-100 V (*)       |
| Red/White  | Engine GND | 90-140         | 28-32          | 25-100 V        | 2 5-100 V (*)      |

(\*) This reading can be used to determine if a stator or pack has a problem. For instance, if you have no spark on any cylinder and the stator's DVA reading is low – disconnect the stator wires and recheck the DVA output. If the reading stays low – the stator is bad. If the reading is now within spec – the pack is bad.

(NOTE) If both Blue wires read low, check the cranking RPM. It must be more than 250 RPM.

3. Check the DVA output on the Green wires from the switch box while connected to the ignition coils. Check the reading on the switch box terminal AND on the ignition coil terminal. You should have a reading of at least 150V or more at both terminals on all cylinders. If the reading is low on one bank and the stator voltage is good, the switch box is usually bad.
4. Check the cranking RPM. A cranking speed less than 250-RPM will not allow the system to spark properly.

## Mercury Troubleshooting

### NO SPARK OR INTERMITTENT SPARK ON ONE OR MORE CYLINDERS:

1. Check the trigger resistance and DVA output as shown below:

| WIRE                  | READ TO                | RESISTANCE | DVA (Connected) | DVA (Disconnected) |
|-----------------------|------------------------|------------|-----------------|--------------------|
| Brown (Black Sleeve)  | White (Yellow Sleeve)  | 800-1400   | 4 V +           | 4 V + (#)          |
| White (Black Sleeve)  | Purple (Yellow Sleeve) | 800-1400   | 4 V +           | 4 V + (#)          |
| Purple (Black Sleeve) | Brown (Yellow Sleeve)  | 800-1400   | 4 V +           | 4 V + (#)          |

(#) This reading can be used to determine if a pack has a problem in the triggering circuit. For instance, if you have no spark on one or two cylinders and the trigger's DVA reading for that cylinder is low – disconnect the trigger wires and recheck the DVA output. If the reading stays low – the trigger is bad. If the reading is now within spec – the pack is bad.

(Service Note) You should get a high or open resistance reading to engine ground from each wire, but you will get a DVA reading of approximately 1-2 Volts. This reading can be used to determine if a pack has a problem in the triggering circuit. For example, if you have no spark on one cylinder and the DVA trigger reading for that cylinder is low – disconnect the trigger wire and recheck the DVA output to ground from the trigger wire. If the reading stays low – the trigger is bad.

2. Check the DVA output on the Green wires from the switch box while connected to the ignition coils. Check the reading on the switch box terminal AND on the ignition coil terminal. You should have a reading of at least 150V or more at both terminals. If the reading is low on one cylinder, disconnect the Green wire from the ignition coil for that cylinder and reconnect it to a load resistor. Retest. If the reading is now good, the ignition coil is likely bad. A continued low reading symptom indicates a bad switch box.
3. Connect a spark gap tester and verify which cylinders are misfiring. If the cylinders are only misfiring above an idle, connect an inductive tachometer to all cylinders and try to isolate the problem cylinders.
4. Check the triggering and charge coil flywheel magnets for cracked, broken and loose magnets.

### SWITCH BOX OR TRIGGER REPEATEDLY BLOWS ON SAME CYLINDER:

1. Check the trigger wires for shorts to engine ground as a shorted trigger wire can destroy a SCR inside the switch box.
2. In contrast, a shorted SCR inside the switch box can destroy a trigger coil. Check the trigger resistance and DVA output (see NO SPARK OR INTERMITTENT SPARK ON ONE OR MORE CYLINDERS above).
3. Replace the ignition coil on the cylinder dropping spark.

### ENGINE WILL NOT SHUT OFF:

Disconnect the stop wire at the switch box. Connect a jumper wire to the stop wire from the switch box and short it to engine ground. If this stops the switch box from sparking, the stop circuit has a fault. Check the key switch, harness and shift switch. If this does not stop the switch box from sparking, replace the switch box. Repeat test as necessary for additional switch boxes.

### WILL NOT ACCELERATE BEYOND 3000-4000 RPM:

1. Disconnect the Yellow wires from the stator to the rectifier and retest. If the engine now has good spark, replace the rectifier.
2. Disconnect the idle stabilizer (advance module) and reset the timing between 23-25 degrees Wide Open Throttle. If the problem clears, discard the idle stabilizer as it is not needed.
3. Connect a DVA meter between the stator's Blue wire and engine ground. Run the engine up to the RPM where the problem is occurring. DVA voltage should increase with RPM. A sharp drop in DVA right before the problem occurs usually indicates a bad stator. (Repeat the test from Blue/White to engine ground and compare the readings).
4. Connect a DVA meter between the stator's Red wire and engine ground. The DVA voltage should show a smooth climb in voltage and remain high through the RPM range. A reading lower than on the Blue wire reading indicates a bad stator. (Repeat the test from Red/White to engine ground and compare the readings).
5. If all cylinders become intermittent, replace both switch boxes.
6. Connect an inductive tachometer to each cylinder in turn and try to isolate the problem. If two or more cylinders on the same bank are dropping out, the problem is likely going to be either the stator or the switch box. A single cylinder dropping spark will likely be a bad switch box or ignition coil. All cylinders not sparking properly usually indicates a bad stator.

## **Mercury Troubleshooting**

7. Perform a high-speed shutdown and read the spark plugs. Check for water. A crack in the block can cause a miss at high speed when the water pressure gets high, but a normal shutdown will mask the problem.
8. Check the triggering and charge coil flywheel magnets for cracked, broken and loose magnets.

### **MISS AT ANY RPM:**

1. Disconnect the Yellow wires from the stator to the rectifier and retest. If the miss clears, replace the rectifier.
2. Disconnect the idle stabilizer (advance module) and reset the timing between 23-25 degrees Wide Open Throttle. If the problem clears, discard the idle stabilizer as it is not needed.
3. In the water or on a Dynameters, check the DVA output on the Green wires from the switch box while connected to the ignition coils. You should have a reading of at least 150V DVA or more, increasing with engine RPM until it reaches 300-400V DVA maximum. A sharp drop in DVA right before the miss becomes apparent on all cylinders will normally be caused by a bad stator. A sharp drop in DVA on less than all cylinders will normally be the switch box or trigger.
4. Connect an inductive tachometer to each cylinder in turn and try to isolate the problem. A high variance in RPM on one cylinder usually indicates a problem in the switch box or ignition coil. Occasionally a trigger will cause this same problem. Check the trigger DVA voltage (see NO SPARK OR INTERMITTENT SPARK ON ONE OR MORE CYLINDERS above).
5. Perform a high-speed shutdown and read the spark plugs. Check for water. A crack in the block can cause a miss at high speed when the water pressure gets high, but a normal shutdown will mask the problem.
6. Check the triggering and charge coil flywheel magnets for cracked, broken and loose magnets.
7. Rotate the stator one bolt hole in either direction and retest.

### **FUEL INJECTORS NOT ACTIVATING:**

1. Check the DVA voltage on the Green, Green/White and Green/Red wires, reference to engine ground at cranking speed. You should read at least 150 volts. If one wire reads low, it will affect 2 fuel injectors.
2. Check the voltage going to the fuel injectors, you should read above 10 volts while cranking the engine.
3. Check the DVA voltage across the fuel injectors, if you see approximately 25-60 volts, the injectors are pulsing. The injectors may be stopped up, possibly the inlet screen filters.

### **FUEL PUMP NOT ACTIVATING:**

1. Check the voltage going to the fuel pump on the Red wire, you should read above 10 volts while cranking the engine.
2. If the voltage is correct going to the fuel pump, connect a jumper wire to the Negative side of the fuel pump and touch it to engine ground. If the pump starts running, measure the amperage from the Negative side of the fuel pump to engine ground. The amperage should not be over 5 amps. If it is, the pump is likely defective and may have damaged the EFI.
3. Disconnect the 16 pin connector going to the EFI and jumper pin 2 to pin 16. If the fuel pump starts running, the circuit is OK and the problem lies elsewhere.
4. If the fuel pump runs when jumped but not when connected to the EFI, check pins 6 and 7 for 12V at keyswitch on in the harness that connects to the EFI. If only one has 12V there is a problem in the harness or keyswitch.

## Mercury Troubleshooting

### Mercury/Force Two Cylinder Engines 1994-2006 Engines Using CDM Modules

#### NO SPARK ON ANY CYLINDER:

1. Disconnect the Black/Yellow stop wires from the harness and retest. If the engine's ignition sparks, the stop circuit has a fault. Check the key switch, harness and shift switch.
2. Disconnect the Yellow wires from the stator to the rectifier and retest. If the engine now has spark, replace the rectifier.
3. Check the cranking RPM. A cranking speed of less than 250-RPM will not allow the system to spark properly. This can be caused by a weak battery, dragging starter, bad battery cables or a mechanical problem inside the engine.
4. Inspect the spark plug wires, boots and spark plugs. Check for chafing on the wiring and harnesses.
5. Inspect and clean all engine and ignition ground connections.
6. Pull on each wire from each CDM harness plug. Make sure all wires are making proper contact inside plugs.
7. Disconnect one CDM module at a time and using a set of piercing probes and jumper wires - short the stator wire in the CDM connector to engine ground. Retest. If the other module starts sparking, the CDM you unplugged is bad.
8. Check the stator resistance and DVA output as follows:

| WIRE        | READ TO     | OEM RESISTANCE | CDI RESISTANCE | DVA (Connected) | DVA (Disconnected) |
|-------------|-------------|----------------|----------------|-----------------|--------------------|
| White/Green | Green/White | 500-700        | 400-550        | 180-400 V       | 200-400 V (*)      |

(\*) This reading can be used to determine if a stator or the CDM modules have a problem. For instance, if you have no spark on any cylinder and the stator's DVA reading is low – disconnect the stator wires and recheck the DVA output. If the reading stays low – the stator is bad. If the reading is now within spec – at least one of the CDM modules is bad.

9. Check the resistance of each of the CDM modules as follows:

|           | RED METER LEAD    | BLACK METER LEAD | READING                                |
|-----------|-------------------|------------------|--|
| CDM Pin # | A                 | C                | 1200-1400 Ohms                         |
| CDM Pin # | D                 | A                | DIODE*                                 |
| CDM Pin # | A                 | D                | DIODE*                                 |
| CDM Pin # | D                 | B                | DIODE*                                 |
| CDM Pin # | B                 | D                | DIODE*                                 |
| CDM Pin # | A                 | B                | DIODE*                                 |
|           | High Tension Lead | A                | OEM 700-1300 Ohms – CDI 2200-2400 Ohms |

\* Diode readings are to be read one way, then reverse the leads and read again. You should get a low reading in one direction and a higher reading in the other.

10. Check the center hub triggering magnet in the flywheel. A loose magnet can cause this problem.
11. Check the triggering and charge coil flywheel magnets for cracked, broken and loose magnets.

#### NO SPARK OR INTERMITTENT SPARK ON ONE CYLINDER:

1. Inspect the spark plug wires, boots and spark plugs. Check for chafing on the wiring and harnesses.
2. Clean and inspect CDM ground wire connections to engine ground.
3. Check the trigger DVA output as shown below:

| WIRE   | READ TO    | RESISTANCE | DVA (Connected) |
|--------|------------|------------|-----------------|
| Purple | Engine GND | Open       | 0.2 V +         |
| White  | Engine GND | Open       | 0.2 V +         |

4. If one cylinder is not sparking, swap the White/Green and Green/White stator wires and retest. If the problem moves to the other cylinder, the stator is likely bad. If no change, replace both CDMs. A continued no spark condition on the same cylinder indicates a bad trigger.
5. If the cylinders are only misfiring up above an idle, connect an inductive tachometer to all cylinders and try to isolate the problem cylinders.
6. Check the resistance of each of the CDM modules (see NO SPARK ON ANY CYLINDER above).



## Mercury Troubleshooting

### CDM OR TRIGGER REPEATEDLY BLOWS ON SAME CYLINDER:

1. Check the trigger wires for shorts to engine ground as a shorted trigger wire can destroy a SCR inside the CDM.
2. In contrast, a shorted SCR inside the CDM can destroy a trigger coil. Check the trigger resistance and DVA output (see NO SPARK ON ANY CYLINDER above).
3. Cut the Black/Yellow stop wire from the CDM not sparking. Measure DC voltage from Black/Yellow (from the harness) to engine ground. Turn the ignition switch on and off several times. DC voltage should never exceed 2V. If it does, the stop circuit has a fault. Check the key switch, harness and shift switch.
4. Replace the CDM on the cylinder dropping spark.

### MISS AT ANY RPM:

1. Disconnect the Yellow wires from the stator to the rectifier and retest. If the miss clears, replace the rectifier.
2. Connect an inductive tachometer to each cylinder in turn and try to isolate the problem. A high variance in RPM on one cylinder usually indicates a problem in the trigger or CDM module. Check the trigger DVA voltage (see NO SPARK OR INTERMITTENT SPARK ON ONE CYLINDER above).
3. Perform a high-speed shutdown and read the spark plugs. Check for water. A crack in the block can cause a miss at high speed when the water pressure gets high, but a normal shutdown will mask the problem.
4. Check the triggering and charge coil flywheel magnets for cracked, broken and loose magnets.
5. Rotate the stator one bolt hole in either direction and retest.

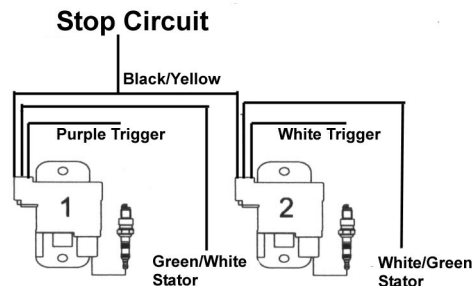

### **Mercury/Force** Three Cylinder Engines 1996-2006 Engines Using CDM Modules

### NO SPARK ON ANY CYLINDER:

1. Cut each Black/Yellow stop wire from each CDM module and disconnect the RPM Limiter's stop wire one at a time and retest. If the engine's ignition sparks, the stop circuit you just cut has a fault. Check the key switch, harness and shift switch.
2. Disconnect the Yellow wires from the stator to the rectifier and retest. If the engine now has spark, replace the rectifier.
3. Check the cranking RPM. A cranking speed of less than 250-RPM will not allow the system to spark properly. This can be caused by a weak battery, dragging starter, bad battery cables or a mechanical problem inside the engine.
4. Inspect the spark plug wires, boots and spark plugs. Check for chafing on the wiring and harnesses.
5. Inspect and clean all engine and ignition ground connections.
6. Pull on each wire from each CDM harness plug. Make sure all wires are making proper contact inside plugs.
7. Disconnect one CDM module at a time and see if the other modules start sparking. If they do, the module you just unplugged is bad. Remember only one side of the stator is connected to one CDM and the other side is connected to two CDM modules. If you disconnect the CDM using the lone side of the stator, you will need to ground that side of the stator.
8. If the bottom two CDM modules are not sparking, swap the connection between the top and middle cylinder. If the middle cylinder starts sparking, replace the top CDM.
9. Check the stator resistance and DVA output as given below:

| WIRE        | READ TO     | OEM RESISTANCE | CDI RESISTANCE | DVA (Connected) | DVA (Disconnected) |
|-------------|-------------|----------------|----------------|-----------------|--------------------|
| White/Green | Green/White | 500-700        | 400-550        | 180-400 V       | 200-400 V (*)      |

(\*) This reading can be used to determine if a stator or the CDM modules have a problem. For instance, if you have no spark on any cylinder and the stator's DVA reading is low – disconnect the stator wires and recheck the

## Mercury Troubleshooting

DVA output. If the reading stays low – the stator is bad. If the reading is now within spec – at least one of the CDM modules is bad.

10. Check the resistance of each of the CDM modules as follows:

|           | RED METER LEAD    | BLACK METER LEAD | READING                                |
|-----------|-------------------|------------------|--|
| CDM Pin # | A                 | C                | 1200-1400 Ohms                         |
| CDM Pin # | D                 | A                | DIODE*                                 |
| CDM Pin # | A                 | D                | DIODE*                                 |
| CDM Pin # | D                 | B                | DIODE*                                 |
| CDM Pin # | B                 | D                | DIODE*                                 |
| CDM Pin # | A                 | B                | DIODE*                                 |
|           | High Tension Lead | A                | OEM 700-1300 Ohms – CDI 2200-2400 Ohms |

\* Diode readings are to be read one way, then reverse the leads and read again. You should get a low reading in one direction and a higher reading in the other.

11. Check the center hub triggering magnet in the flywheel. A loose magnet can cause this problem.  
 12. Check the triggering and charge coil flywheel magnets for cracked, broken and loose magnets.

### NO SPARK OR INTERMITTENT SPARK ON ONE OR MORE CYLINDERS:

1. Inspect the spark plug wires, boots and spark plugs. Check for chafing on the wiring and harnesses.
2. Clean and inspect CDM ground wire connections to engine ground.
3. Check the trigger DVA output as shown below:

| WIRE   | READ TO    | RESISTANCE | DVA (Connected) |
|--------|------------|------------|-----------------|
| Purple | Engine GND | Open       | 0.2 V +         |
| White  | Engine GND | Open       | 0.2 V +         |
| Brown  | Engine GND | Open       | 0.2 V +         |

4. If (#1) or (#3) or (#1 and #2) or (#2 and #3) is not sparking, swap the White/Green and Green/White stator wires and retest. If the problem moves to the other cylinder(s), the stator is likely bad. If no change, replace all CDMs. A continued no spark condition on the same cylinder(s) indicates a bad trigger.
5. If #1 CDM module is not sparking, disconnect the #2 CDM module and see if the #1 CDM module starts sparking. If it does, the module you just unplugged is bad. If it does not, reconnect #2, then disconnect the #3 CDM module and see if the #1 module starts sparking. If it does, the module you just unplugged is bad.
6. If there is no spark on either # 2 or #3, swap locations with #1 and see if the problem moves. If it does, the module is bad. A continued no spark on the same cylinder indicates a bad trigger.
7. If the cylinders are only misfiring above an idle, connect an inductive tachometer to all cylinders and try to isolate the problem cylinders.
8. Check the resistance of each of the CDM modules (see NO SPARK ON ANY CYLINDER above).

### CDM OR TRIGGER REPEATEDLY BLOWS ON SAME CYLINDER:

1. Check the trigger wires for shorts to engine ground as a shorted trigger wire can destroy a SCR inside the CDM.
2. In contrast, a shorted SCR inside the CDM can destroy a trigger coil. Check the trigger resistance and DVA output (see NO SPARK ON ANY CYLINDER above).
3. Cut the Black/Yellow stop wire from the CDM not sparking. Measure DC voltage from Black/Yellow (from the harness) to engine ground. Turn the ignition switch on and off several times. DC voltage should never exceed 2V. If it does, the stop circuit has a fault. Check the key switch, harness and shift switch.
4. Replace the CDM on the cylinder dropping spark.

### MISS AT ANY RPM:

1. Disconnect the Yellow wires from the stator to the rectifier and retest. If the miss clears, replace the rectifier.
2. Connect an inductive tachometer to each cylinder in turn and try to isolate the problem. A high variance in RPM on one cylinder usually indicates a problem in the trigger or CDM module. Check the trigger DVA voltage (see NO SPARK OR INTERMITTENT SPARK ON ONE OR MORE CYLINDERS above).
3. Perform a high-speed shutdown and read the spark plugs. Check for water. A crack in the block can cause a miss at high speed when the water pressure gets high, but a normal shutdown will mask the problem.
4. Check the triggering and charge coil flywheel magnets for cracked, broken and loose magnets.
5. Rotate the stator one bolt hole in either direction and retest.

# Mercury Troubleshooting

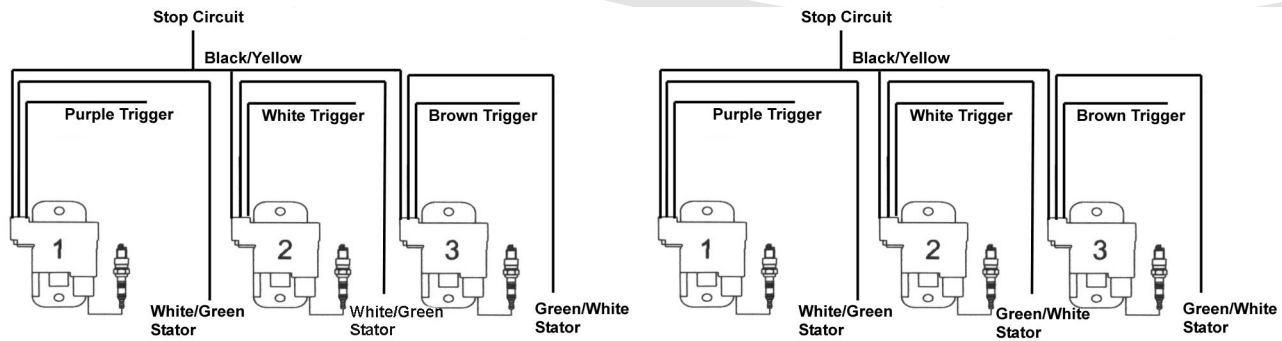

## Mercury/Force Four Cylinder Engines 1996-2006 Engines Using CDM Modules

### NO SPARK ON ANY CYLINDER:

1. Cut each Black/Yellow stop wire from each CDM module and disconnect the RPM Limiter's stop wire one at a time and retest. If the engine's ignition sparks, the stop circuit you just cut has a fault. Check the key switch, harness and shift switch.
2. Disconnect the Yellow wires from the rectifier and retest. If the engine has spark, replace the rectifier.
3. Check the cranking RPM. A cranking speed of less than 250-RPM will not allow the system to spark properly. This can be caused by a weak battery, dragging starter, bad battery cables or a mechanical problem inside the engine.
4. Inspect the spark plug wires, boots and spark plugs. Check for chafing on the wiring and harnesses.
5. Inspect and clean all engine and ignition ground connections.
6. Pull on each wire from each CDM harness plug. Make sure all wires are making proper contact inside plugs.
7. Disconnect the CDM modules one at a time and see if you get spark back on the other cylinders. A shorted stop circuit in one CDM will prevent ALL cylinders from sparking.
8. Check the stator resistance and DVA output as given below:

| WIRE | READ TO | OEM RESISTANCE | CDI RESISTANCE | DVA (Connected) | DVA<br>(Disconnected) |
|------|---------|----------------|----------------|-----------------|-----------------------|
|------|---------|----------------|----------------|-----------------|-----------------------|

|             |             |         |         |           |               |
|-------------|-------------|---------|---------|-----------|---------------|
| White/Green | Green/White | 500-700 | 400-550 | 180-400 V | 200-400 V (*) |
|-------------|-------------|---------|---------|-----------|---------------|

(\*) This reading can be used to determine if a stator or the CDM modules have a problem. For instance, if you have no spark on any cylinder and the stator's DVA reading is low – disconnect the stator wires and recheck the DVA output. If the reading stays low – the stator is bad. If the reading is now within spec – at least one of the CDM modules is bad.

9. Check the resistance of each of the CDM modules as follows:

|           | RED METER LEAD | BLACK METER LEAD | READING        |
|-----------|----------------|------------------|----------------|
| CDM Pin # | A              | C                | 1200-1400 Ohms |
| CDM Pin # | D              | A                | DIODE*         |
| CDM Pin # | A              | D                | DIODE*         |
| CDM Pin # | D              | B                | DIODE*         |
| CDM Pin # | B              | D                | DIODE*         |
| CDM Pin # | A              | B                | DIODE*         |

High Tension Lead A

OEM 700-1300 Ohms – CDI 2200-2400 Ohms

\* Diode readings are to be read one way, then reverse the leads and read again. You should get a low reading in one direction and a higher reading in the other.

10. Check the center hub triggering magnet in the flywheel. A loose magnet can cause this problem.
11. Check the triggering and charge coil flywheel magnets for cracked, broken and loose magnets.

## Mercury Troubleshooting

### NO SPARK OR INTERMITTENT SPARK ON ONE OR MORE CYLINDERS:

1. Inspect the spark plug wires, boots and spark plugs. Check for chafing on the wiring and harnesses.
2. Clean and inspect CDM ground wire connections to engine ground.
3. Check the trigger DVA output as shown below:

| WIRE                    | READ TO    | RESISTANCE | DVA (Connected) |
|-------------------------|------------|------------|-----------------|
| Purple/White/Brown/Blue | Engine GND | Open       | 0.2 V +         |

4. If (#1 and/or #2) or (#3 and/or #4) is not sparking, swap the White/Green and Green/White stator wires and retest. If the problem moves to the other cylinders, the stator is likely bad. If no change, replace all CDMs. A continued no spark condition on the same cylinders indicates a bad trigger.
5. Disconnect the CDM modules one at a time and see if you get spark back on the problem cylinders. If it does, replace all CDMs.
6. If the cylinders are only misfiring above an idle, connect an inductive RPM meter to all cylinders and try to isolate the problem cylinders.
7. Check the resistance of each of the CDM modules (see NO SPARK ON ANY CYLINDER above).

### CDM OR TRIGGER REPEATEDLY BLOWS ON SAME CYLINDER:

1. Check the trigger wires for shorts to engine ground as a shorted trigger wire can destroy a SCR inside the CDM.
2. In contrast, a shorted SCR inside the CDM can destroy a trigger coil. Check the trigger resistance and DVA output (see NO SPARK ON ANY CYLINDER above).
3. Cut the Black/Yellow stop wire from the CDM not sparking. Measure DC voltage from Black/Yellow (from the harness) to engine ground. Turn the ignition switch on and off several times. DC voltage should never exceed 2V. If it does, the stop circuit has a fault. Check the key switch, harness and shift switch.
4. Replace the CDM on the cylinder dropping spark.

### MISS AT ANY RPM:

1. Disconnect the Yellow wires from the stator to the rectifier and retest. If the miss clears, replace the rectifier.
2. Connect an inductive tachometer to each cylinder in turn and try to isolate the problem. A high variance in RPM on one cylinder usually indicates a problem in the trigger or CDM module. Check the trigger DVA voltage (see NO SPARK OR INTERMITTENT SPARK ON ONE OR MORE CYLINDERS above).
3. Perform a high-speed shutdown and read the spark plugs. Check for water. A crack in the block can cause a miss at high speed when the water pressure gets high, but a normal shutdown will mask the problem.
4. Check the triggering and charge coil flywheel magnets for cracked, broken and loose magnets.
5. Rotate the stator one bolt hole in either direction and retest.
6. Use the wiring diagram below as an aid in locating areas where problems may occur. Remember a short in either #1 or #2 can cause either #3 or #4 not to have spark.

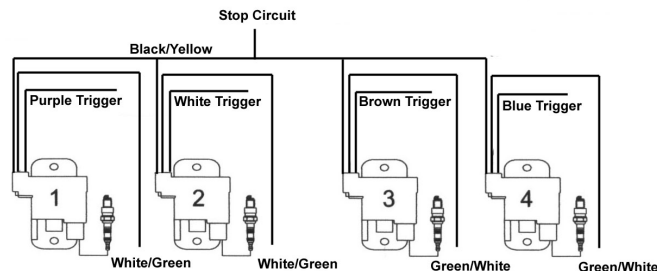

# Mercury Troubleshooting

## **Mercury** **Six Cylinder Engines** **1996-2005 2.5 L Engines Using CDM Modules**

### **NO SPARK ON ANY CYLINDER:**

1. Cut each Black/Yellow stop wire from each CDM module and disconnect the RPM Limiter's stop wire one at a time and retest. If the engine's ignition sparks, the stop circuit you just cut has a fault. Check the key switch, harness and shift switch.
2. Disconnect the Yellow wires from the rectifier and retest. If the engine has spark, replace the rectifier.
3. Disconnect the ICM and reconnect the trigger to the CDM harness. If the engine has spark, verify 12V DC on the Purple wire to the ICM. If 12V DC is present, the ICM is faulty. If 12V DC is not present, check the key switch and harness.
4. Check the cranking RPM. A cranking speed of less than 250-RPM will not allow the system to spark properly. This can be caused by a weak battery, dragging starter, bad battery cables or a mechanical problem inside the engine.
5. Inspect the spark plug wires, boots and spark plugs. Check for chafing on the wiring and harnesses.
6. Inspect and clean all engine and ignition ground connections.
7. Pull on each wire from each CDM harness plug. Make sure all wires are making proper contact inside plugs.
8. Disconnect the CDM modules one at a time and see if you get spark back on the other cylinders. A shorted stop circuit in one CDM will prevent ALL cylinders from sparking.
9. Check the stator resistance and DVA output as given below:

| WIRE        | READ TO     | OEM RESISTANCE | CDI RESISTANCE | DVA (Connected) | DVA(Disconnected) |
|-------------|-------------|----------------|----------------|-----------------|-------------------|
| White/Green | Green/White | 380-430        | 380-430        | 160-400 V       | 200-400 V (*)     |

(\*) This reading can be used to determine if a stator or the CDM modules have a problem. For instance, if you have no spark on any cylinder and the stator's DVA reading is low – disconnect the stator wires and recheck the DVA output. If the reading stays low – the stator is bad. If the reading is now within spec – at least one of the CDM modules is bad.

10. Check the resistance of each of the CDM modules as follows:

|           | RED METER LEAD    | BLACK METER LEAD | READING                                |
|-----------|-------------------|------------------|--|
| CDM Pin # | A                 | C                | 1200-1400 Ohms                         |
| CDM Pin # | D                 | A                | DIODE*                                 |
| CDM Pin # | A                 | D                | DIODE*                                 |
| CDM Pin # | D                 | B                | DIODE*                                 |
| CDM Pin # | B                 | D                | DIODE*                                 |
| CDM Pin # | A                 | B                | DIODE*                                 |
|           | High Tension Lead | A                | OEM 700-1300 Ohms – CDI 2200-2400 Ohms |

\* Diode readings are to be read one way, then reverse the leads and read again. You should get a low reading in one direction and a higher reading in the other.

11. Check the center hub triggering magnet in the flywheel. A loose magnet can cause this problem.
12. Check the triggering and charge coil flywheel magnets for cracked, broken and loose magnets.

### **NO SPARK OR INTERMITTENT SPARK ON ONE OR MORE CYLINDERS:**

1. Inspect the spark plug wires, boots and spark plugs. Check for chafing on the wiring and harnesses.
2. Clean and inspect CDM ground wire connections to engine ground.
3. Check the trigger resistance and DVA output as given below:

| WIRE   | READ TO | OEM OHMS  | CDI OHMS | DVA (Connected) | DVA (Disconnected at Trigger) |
|--------|---------|-----------|----------|-----------------|-------------------------------|
| Purple | Blue    | 1100-1400 | 850-1050 | 0.4 V +         | 4 V + (#)                     |
| White  | Red     | 1100-1400 | 850-1050 | 0.4 V +         | 4 V + (#)                     |
| Brown  | Yellow  | 1100-1400 | 850-1050 | 0.4 V +         | 4 V + (#)                     |

(#) This reading can be used to determine if a CDM has a problem in the triggering circuit. For instance, if you have no spark on one or two cylinders and the trigger's DVA reading for that cylinder is low – disconnect the trigger wires and recheck the DVA output. If the reading stays low – the trigger is bad. If the reading is now within



## Mercury Troubleshooting

spec – the CDM is bad.

4. Disconnect the CDM modules one at a time and see if you get spark back on the problem cylinders. If it does, replace all CDMs.
5. If the cylinders are only misfiring above an idle, connect an inductive RPM meter to all cylinders and try to isolate the problem cylinders.
6. Check the resistance of each of the CDM modules (see NO SPARK ON ANY CYLINDER above).

### CDM OR TRIGGER REPEATEDLY BLOWS ON SAME CYLINDER:

1. Check the trigger wires for shorts to engine ground as a shorted trigger wire can destroy a SCR inside the CDM.
2. In contrast, a shorted SCR inside the CDM can destroy a trigger coil. Check the trigger resistance and DVA output (see NO SPARK ON ANY CYLINDER above).
3. Cut the Black/Yellow stop wire from the CDM not sparking. Measure DC voltage from Black/Yellow (from the harness) to engine ground. Turn the ignition switch on and off several times. DC voltage should never exceed 2V. If it does, the stop circuit has a fault. Check the key switch, harness and shift switch.
4. Replace the CDM on the cylinder dropping spark.

### MISS AT ANY RPM:

1. Disconnect the Yellow wires from the stator to the rectifier and retest. If the miss clears, replace the rectifier.
2. Connect an inductive tachometer to each cylinder in turn and try to isolate the problem. A high variance in RPM on one cylinder usually indicates a problem in the trigger or CDM module. Check the trigger DVA voltage (see NO SPARK OR INTERMITTENT SPARK ON ONE OR MORE CYLINDERS above).
3. Perform a high-speed shutdown and read the spark plugs. Check for water. A crack in the block can cause a miss at high speed when the water pressure gets high, but a normal shutdown will mask the problem.
4. Check the triggering and charge coil flywheel magnets for cracked, broken and loose magnets.
5. Rotate the stator one bolt hole in either direction and retest.
6. Index the flywheel and check the timing on ALL cylinders. On carbureted models, the control module rev limit function starts to retard timing in sequence (2, 3, 4, 5, 6, 1) at 5800-6000 RPM. The control module will retard the timing each cylinder up to 30 degrees (starting with #2) and then stop firing that cylinder if the RPM is still above the limit. It will continue to retard, then shut down each cylinder until the engine drops below the limit.

### NO SPARK OR INTERMITTENT SPARK ON #1, #2 and #3 OR #4, #5 and #6 CYLINDERS:

1. Check the cranking RPM. A cranking speed less than 250-RPM will not allow the system to spark properly.
2. Disconnect the CDM modules one at a time and see if you get spark back on the problem cylinders.
3. Check the stator resistance and DVA output as given below:

| WIRE        | READ TO     | OEM RESISTANCE | CDI RESISTANCE | DVA (Connected) | DVA (Disconnected) |
|-------------|-------------|----------------|----------------|-----------------|--------------------|
| White/Green | Green/White | 380-430        | 380-430        | 160-400 V       | 200-400 V (*)      |
| White/Green | Engine GND  | Open           | Open           | 160-400 V       | < 2 V              |
| Green/White | Engine GND  | Open           | Open           | 160-400 V       | < 2 V              |

(\*) This reading can be used to determine if a stator or the CDM modules have a problem. For instance, if you have no spark on any cylinder and the stator's DVA reading is low – disconnect the stator wires and recheck the DVA output. If the reading stays low – the stator is bad. If the reading is now within spec – at least one of the CDM modules is bad.

4. Check the trigger resistance and DVA output (see NO SPARK OR INTERMITTENT SPARK ON ONE OR MORE CYLINDERS above).
5. Check the trigger DVA output as given below:

| WIRE   | READ TO    | RESISTANCE | DVA (Connected) |
|--------|------------|------------|-----------------|
| Purple | Engine GND | Open       | 0.2 to 2V       |
| White  | Engine GND | Open       | 0.2 to 2V       |
| Brown  | Engine GND | Open       | 0.2 to 2V       |
| Blue   | Engine GND | Open       | 0.2 to 2V       |
| Red    | Engine GND | Open       | 0.2 to 2V       |
| Yellow | Engine GND | Open       | 0.2 to 2V       |

## Mercury Troubleshooting

- If (#1, #2 and #3) or (#4, #5 and #6) is not sparking, swap the White/Green and Green/White stator wires and retest. If the problem moves to the other cylinders, the stator is likely bad. If no change, replace all CDMs. A continued no spark condition on the same cylinders indicates a bad trigger.
- The connection guide below will assist you in locating areas where problems can occur. Remember, a short in either #1, #2 or #3 can cause either # 4, #5 or #6 not to have spark.

### ENGINE HAS ERRATIC TIMING OR ADVANCED TIMING:

- Check the trigger magnet in the flywheel to see if it is loose or cracked.
- Disconnect the 4 wire Detonation Controller and check the DVA voltage on the Black/White wire, reference to engine ground. You should read between 25 and 40 volts. If the voltage is low, replace the TPM Control Module.
- Replace the TPM Controller.

### ENGINE HARD TO SHIFT INTO OR OUT OF GEAR:

Check the Bias DVA voltage on the Black/White wire, reference to engine ground. You should read between 25 and 40 volts. If the voltage is low, replace the TPM Control Module.

### ENGINE MIS-FIRES OVER 2000 RPM:

- Connect a CDM Test Harness (CDI P/N: 511-5207A 1) to the CDM modules and check the DVA voltage from the stator and trigger.
  - You should have between 160 and 320 volts on the stator. If the voltage is low, check the stator resistance. If it is high, check the CDM and ground connections.
  - The trigger should read between 2 and 8 volts. If the voltage is low, check the trigger resistance. If it is high, check the CDM and ground connections.

NOTE: If the stator read low on three cylinder and they share the same color code, swap the stator wires and retest. If the problem moves, replace the stator. If the problem stays on the same CDMs, one of them is defective.
- Check the DVA voltage on the Black/White wire, reference to engine ground. You should read between 25 and 40 volts. If the voltage is low, replace the TPM Control Module.

### ENGINE DOUBLE FIRING:

- Check the Bias DVA voltage on the Black/White wire, reference to engine ground. You should read between 25 and 40 volts. If the voltage is low, replace the TPM Control Module.
- Swap the CDM that is double-firing with another CDM firing cleanly. If the problem moves, replace the defective CDM.

### FUEL INJECTORS NOT ACTIVATING:

- Check the DVA voltage on the Green, Green/White and Green/Red wires, reference to engine ground at cranking speed. You should read at least 8 volts. If the voltage is low, check the voltage on the Purple wire going to the Controller, you should read above 10 volts while cranking the engine.
- Check the voltage going to the fuel injectors, you should read above 10 volts while cranking the engine.
- Check the DVA voltage across the fuel injectors, if you see approximately 25-60 volts, the injectors are pulsing. You may have stopped up injectors.

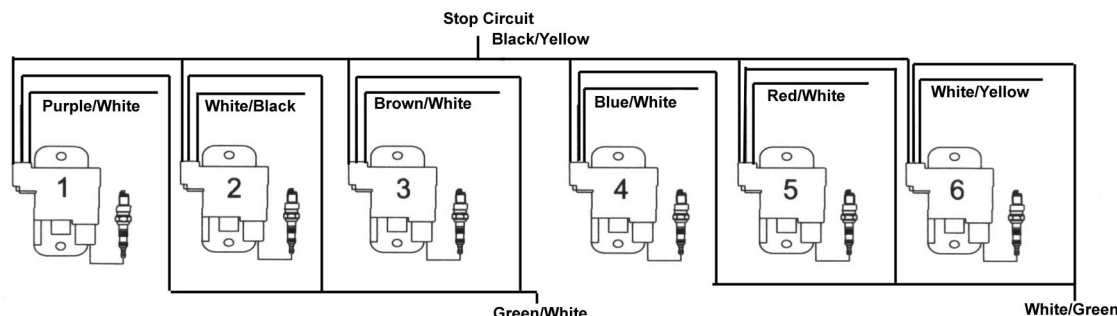

**Mercury**

## Mercury Troubleshooting

### Six Cylinder Engines 1994-2003 225/250 3.0L Engines Using CDM Modules

Service Notes: Please use the Factory recommended spark plug (currently Champion QL77CC) gapped at 0.035" for EFI engines and 0.040" for Carbureted engines.

The Crank Position Sensor should be gapped at 0.040" +/- 0.020".

The maximum spark timing is controlled by the ignition ECU and is non-adjustable. As long as the ECU, Crank Position Sensor and Throttle Position Indicator are functioning properly, the maximum timing will be correct.

#### NO SPARK OR WEAK SPARK ON ANY CYLINDER:

1. Disconnect the Black/Yellow stop wires from the harness. Retest. If the engine's ignition now has spark, the stop circuit has a fault. Check the key switch, harness and shift switch.
2. Inspect the spark plug wires, boots and spark plugs. Check for chafing on the wiring and harnesses.
3. Inspect and clean all engine and ignition ground connections.
4. Check the Stator Harness for loose connections.
5. Check the Alternator for dragging and shorted diodes.
6. Check the Crank Position Sensor resistance as given below:

| WIRE | READ TO | RESISTANCE |
|------|---------|------------|
| Red  | White   | 900-1300   |

#### NO SPARK OR WEAK SPARK ON ONE CYLINDER:

1. Inspect the spark plug wires, boots and spark plugs. Check for chafing on the wiring and harnesses.
2. Clean and inspect CDM ground wire connection to engine ground.
3. If the cylinders are only misfiring above an idle, connect an inductive RPM meter to all cylinders and try to isolate the problem cylinders.
4. Check the Stator resistance and DVA output as given below:

| WIRE         | READ TO    | RESISTANCE | DVA (Connected) |
|--------------|------------|------------|-----------------|
| Green        | Engine GND | 990-1210   | 100 V +         |
| Green/Red    | Engine GND | 990-1210   | 100 V +         |
| Green/Yellow | Engine GND | 990-1210   | 100 V +         |
| Green/Blue   | Engine GND | 990-1210   | 100 V +         |
| Green/Orange | Engine GND | 990-1210   | 100 V +         |
| Green/Black  | Engine GND | 990-1210   | 100 V +         |

5. Check the resistance of each of the CDM modules as follows:

|           | RED METER LEAD    | BLACK METER LEAD | READING                                |
|-----------|-------------------|------------------|--|
| CDM Pin # | A                 | C                | 1200-1400 Ohms                         |
| CDM Pin # | D                 | A                | DIODE*                                 |
| CDM Pin # | A                 | D                | DIODE*                                 |
| CDM Pin # | D                 | B                | DIODE*                                 |
| CDM Pin # | B                 | D                | DIODE*                                 |
| CDM Pin # | A                 | B                | DIODE*                                 |
|           | High Tension Lead | A                | OEM 700-1300 Ohms – CDI 2200-2400 Ohms |

\* Diode readings are to be read one way, then reverse the leads and read again. You should get a low reading in one direction and a higher reading in the other.

#### TIMING FLUCTUATES:

Service Notes: It is normal for timing to fluctuate 2° @ idle.

If engine overheats (above 200°F), Engine Temperature Sensor will retard timing to limit RPM to 3000.

If engine RPM exceeds 6000, over-rev circuit in ECU will retard timing to reduce RPM.

If engine RPM drops below 475, idle stabilizer in ECU will advance timing 3° to 6°.

1. Clean and inspect all ground connections.
2. Check the Crank Position Sensor gap (0.040" +/- 0.020") and resistance as given below:

| WIRE | READ TO | RESISTANCE |
|------|---------|------------|
| Red  | White   | 900-1300   |

## **Mercury Troubleshooting**

3. Check the Throttle Position Sensor and the Engine Temperature Sensor.
4. Check the ECU.

### **TIMING WILL NOT ADVANCE:**

Service Note: If timing will not advance on only one cylinder, check wiring between Ignition Module and ECU. If wiring is OK, replace Ignition Module.

1. Check the Crank Position Sensor and the Throttle Position Sensor.
2. Check the ECU.

### **ENGINE MISSES AT HIGH RPM:**

1. Check the Ignition Modules.
2. Check the Crank Position Sensor.
3. Check the Alternator's Red output lead for tightness.
4. Check the ECU.
5. Check for correct spark plugs (use Champion QL77CC).

### **ENGINE HARD TO START WHEN COLD:**

1. Check the Enrichment Solenoid (Carbureted engines).
2. Check the Engine Temperature Sensor and the Crank Position Sensor.
3. Check the ECU.
4. Check the Harness for loose connections between ECU and Starter Solenoid.

### **ENGINE MISSES @ LOW RPM, BUT RUNS SMOOTH @ HIGH RPM:**

1. Check the Harness for loose connections between ECU and Ignition Modules.
2. Check the Ignition Modules.

### **ENGINE STARTS HARD WHEN HOT:**

1. Check the Enrichment Solenoid (Carbureted engines).
2. Check the Engine Temperature Sensor and the Crank Position Sensor.

### **ENGINE WILL NOT RUN OVER 3000 RPM AND IS NOT OVERHEATING:**

1. Check the Engine Temperature Sensor and the Throttle Position Sensor.
2. Check the ECU, Map Sensor and Shift Interrupt Switch.

## **Tohatsu/Nissan Troubleshooting**

### **Tohatsu/Nissan 2 STROKE Carbureted Engines**

#### **MISS AT ANY RPM:**

1. If the boat is equipped with a Hummingbird I.D. depth finder, disconnect the power to it and retest. If the miss is gone, switch to a different depth finder. See Tohatsu Service Bulletin # 1200, dated 9/14/1990.
2. Check fuel lines/tank for restrictions, leaks or loose connections.
3. Check fuel pump diaphragms for holes, allowing extra fuel at high RPM.
4. Verify correct spark plugs are installed and are not fouled.
5. Disconnect the stop switch and retest. If the engine performs properly, the stop circuit has a fault.

#### **2.5A, 2.5A2, 3.5A, 3.5A2, 3.5B, 3.5B2 2005 and Older**

##### **NO SPARK:**

1. Disconnect the Black and Brown stop wires and retest. If you now have spark, the stop circuit has a fault.
2. Test the stator (exciter) stator coil as follows:

| <u>Red Lead</u> | <u>Black Lead</u>     | <u>Resistance</u> | <u>DVA Connected</u> |
|-----------------|-----------------------|-------------------|----------------------|
| White           | Component Gnd (Black) | 280-420           | 110 V Minimum        |
| Orange (CD)     | Component Gnd (Black) | -                 | 110 V Minimum        |

If the above readings are OK and there is no spark, the ignition coil is likely defective.

##### **ENGINE WILL NOT SHUT OFF:**

Short the Brown stop wire (from CD) to engine ground, if the engine shuts down, check the stop switch and harness.

#### **4C, 5B, 5C 2005 and Older**

##### **NO SPARK:**

1. Disconnect the Black and Brown stop wires and retest. If you now have spark, the stop circuit has a fault.
2. Test the stator (exciter) and trigger (pulsar) stator coils as follows:

| <u>Red Lead</u> | <u>Black Lead</u>     | <u>Resistance</u> | <u>DVA Connected</u> |
|-----------------|-----------------------|-------------------|----------------------|
| White           | Red/Black             | 93-140            | 110 V Minimum*       |
| Red/Wht         | Component Gnd (Black) | 80-117            | 3 V Minimum**        |
| Black/Yellow    | Component Gnd (Black) | -                 | 110 V Minimum        |

If the above readings are OK and there is no spark, the ignition coil is likely defective.

\* A low resistance or DVA reading indicates the exciter coil is defective and needs to be rebuilt.

\*\* A low resistance or DVA reading indicates the pulsar coil is defective and needs to be rebuilt.

##### **ENGINE WILL NOT SHUT OFF:**

Short the Brown stop wire (from CD) to engine ground, if the engine shuts down, check the stop switch and harness.

#### **6B, 8B, 9.8B 2005 and Older**

##### **NO SPARK:**

1. Disconnect the Black and Brown stop wires and retest. If you now have spark, the stop circuit has a fault.
2. Test the stator (exciter) stator coil as follows:

| <u>Red Lead</u> | <u>Black Lead</u> | <u>Resistance</u> | <u>DVA Connected</u> |
|-----------------|-------------------|-------------------|----------------------|
| Green           | Black             | 224-336           | 110 V Minimum*       |

If the above reading is OK and there is no spark, the CDI is likely defective.

\* A low resistance or DVA reading indicates the exciter coil is defective and needs to be rebuilt.

##### **ENGINE WILL NOT SHUT OFF:**

Short the Brown stop wire (from CD) to engine ground, if the engine shuts down, check the stop switch and harness.

##### **NO SPARK ON ONE CYLINDER:**

If only one spark plug has spark, the internal ignition coil is defective. The power pack will need to be replaced.



## Tohatsu/Nissan Troubleshooting

### 9.9B, 9.9B2, 12C2, 15B2, 18C2 1986-1992 (CU-15)

**NO SPARK:**

1. Disconnect the Black and Brown stop wires and retest. If you now have spark, the stop circuit has a fault.
2. Test the stator (exciter) and trigger (pulsar) stator coils as follows:

| Red Lead     | Black Lead            | Resistance | DVA Connected  |
|--------------|-----------------------|------------|----------------|
| Red          | Component Gnd (Black) | 168-252    | 110 V Minimum* |
| Blue         | Component Gnd (Black) | 30-46      | 3 V Minimum**  |
| Black/Yellow | Component Gnd (Black) | -          | 110 V Minimum  |

If the above readings are OK and there is no spark, the ignition coil is likely defective.

\* A low resistance or DVA reading indicates the exciter coil is defective and needs to be rebuilt.

\*\* A low resistance or DVA reading indicates the pulsar coil is defective and needs to be rebuilt.

**NO SPARK ON ONE CYLINDER:**

If only one spark plug has spark, the ignition coil is defective and will need to be replaced.

**ENGINE WILL NOT SHUT OFF:**

Short the Brown stop wire (from CD) to engine ground, if the engine shuts down, check the stop switch and harness.

### 9.9C, 9.9D, 15C, 15D, 18D, 18E 1993-1997 (3G2060601M)

**NO SPARK:**

1. Disconnect the Black and Brown stop wires and retest. If you now have spark, the stop circuit has a fault.
2. Test the stator (exciter) and trigger (pulsar) stator coils as follows:

| Red Lead     | Black Lead            | Resistance | DVA Connected  |
|--------------|-----------------------|------------|----------------|
| Red          | Component Gnd (Black) | 168-252    | 110 V Minimum* |
| Blue         | Component Gnd (Black) | 30-46      | 3 V Minimum**  |
| Black/Yellow | Component Gnd (Black) | -          | 110 V Minimum  |

If the above readings are OK and there is no spark, the ignition coil is likely defective.

\* A low resistance or DVA reading indicates the exciter coil is defective and needs to be rebuilt.

\*\* A low resistance or DVA reading indicates the pulsar coil is defective and needs to be rebuilt.

**NO SPARK ON ONE CYLINDER:**

If only one spark plug has spark, the ignition coil is defective and will need to be replaced.

**ENGINE WILL NOT SHUT OFF:**

Short the Brown stop wire (from CD) to engine ground, if the engine shuts down, check the stop switch and harness.

### 9.9D2, 15D2, 18E2 1998 and Newer (3G2060602M)

**NO SPARK:**

1. Disconnect the Black and Brown stop wires and retest. If you now have spark, the stop circuit has a fault.
2. Test the stator (exciter) and trigger (pulsar) stator coils as follows:

| Red Lead     | Black Lead            | Resistance | DVA Connected                    |
|--------------|-----------------------|------------|----------------------------------|
| Red          | Blue                  | 130-195    | 110 V Minimum*                   |
| Blue         | Component Gnd (Black) | -          | 3 V Minimum**                    |
| Black/Yellow | Component Gnd (Black) | -          | 110 V Minimum CDI Output to coil |

If the above readings are OK and there is no spark, the ignition coil is likely defective.

\* A low resistance or DVA reading indicates the exciter coil is defective and needs to be rebuilt.

\*\* Has a 2 wire exciter but tests like a pulsar (trigger).

\*\*\* A low DVA reading indicates the C D is defective if the exciter tests good.

**NO SPARK ON ONE CYLINDER:**

If only one spark plug has spark, the ignition coil is defective and will need to be replaced.

**ENGINE WILL NOT SHUT OFF:**

Short the Brown stop wire (from CD) to engine ground, if the engine shuts down, check the stop switch and harness.

## Tohatsu/Nissan Troubleshooting

### 25C2, 30A, 30A2, 30A3, 40C, 50C, 50D, 60A, 70A (2 Cyl) (CD with internal Coil)

#### NO SPARK ON ANY CYLINDER:

1. Disconnect the Black and Brown stop wires and retest. If you now have spark, the stop circuit has a fault.
2. Test the stator (exciter) and trigger (pulsar) stator coils as follows:

| Red Lead | Black Lead            | Resistance | DVA Connected  |
|----------|-----------------------|------------|----------------|
| Red      | Component Gnd (Black) | 232-348    | 110 V Minimum* |
| Blue     | Component Gnd (Black) | 30-46      | 3 V Minimum**  |

\* A low resistance or DVA reading indicates the exciter coil is defective and needs to be rebuilt.

\*\* A low resistance or DVA reading indicates the pulsar coil is defective and needs to be rebuilt.

#### NO SPARK ON ONE CYLINDER:

If only one spark plug has spark, the internal ignition coil is defective. The power pack will need to be replaced.

#### ENGINE WILL NOT SHUT OFF:

Short the Brown stop wire (from CD) to engine ground, if the engine shuts down, check the stop switch and harness.

### 25C3, 30A4 (3P0060600)

#### NO SPARK ON ANY CYLINDER:

1. Disconnect the Black and Brown stop wires and retest. If you now have spark, the stop circuit has a fault.
2. Test the stator (exciter) and trigger (pulsar) stator coils as follows:

| Red Lead     | Black Lead            | Resistance | DVA Connected    |
|--------------|-----------------------|------------|------------------|
| Red          | Blue                  | 131-195    | 110 V Minimum*   |
| Blue         | Component Gnd (Black) | -          | 3 V Minimum**    |
| Black/Yellow | Component Gnd (Black) | 0.2-0.3    | 110 V Minimum*** |

\* A low resistance or DVA reading indicates the exciter coil is defective and needs to be rebuilt.

\*\* Has a 2 wire exciter but tests like a pulsar (trigger).

\*\*\* A low DVA reading indicates the C D is defective if the exciter tests good.

#### NO SPARK ON ONE CYLINDER:

If only one spark plug has spark, the ignition coil is defective and will need to be replaced.

#### ENGINE WILL NOT SHUT OFF:

Short the Brown stop wire (from CD) to engine ground, if the engine shuts down, check the stop switch and harness.

### 40D, 50D2 (3 Cylinder)

#### NO SPARK ON ANY CYLINDER:

1. Disconnect the Black and Brown stop wires and retest. If you now have spark, the stop circuit has a fault.
2. Disconnect the regulator/rectifier. If spark returns, replace the regulator/rectifier.
3. Test the stator (exciter) and trigger (pulsar) stator coils as follows:

| Red Lead | Black Lead | Resistance | DVA Connected                     |
|----------|------------|------------|-----------------------------------|
| Org      | Wht/Grn    | 496-744    | 110 V Minimum                     |
| Org      | Eng Ground | 496-744    | 110 V Minimum                     |
| Wht/Grn  | Eng Ground | 496-744    | 110 V Minimum                     |
| Wht/Red  | Black      | 152-228    | 3 V Minimum**                     |
| Wht/Blk  | Black      | 152-228    | 3 V Minimum**                     |
| Wht/Blue | Black      | 152-228    | 3 V Minimum**                     |
| Blk/Wht  | Black      |            | 110 V Minimum CDI Output to coil* |
| Blk/Red  | Black      |            | 110 V Minimum CDI Output to coil* |
| Blk/Grn  | Black      |            | 110 V Minimum CDI Output to coil* |

\* A low resistance or DVA reading usually indicates the exciter coil is defective and needs to be replaced.

\*\* A low resistance or DVA reading indicates the pulsar coil is defective and needs to be replaced.

#### NO SPARK ON ONE CYLINDER:

1. Check the resistance and DVA of the trigger as shown under " NO SPARK ON ANY CYLINDER":
2. Swap the ignition coil with no spark with one that is firing. If the no spark condition follows the coil, replace the coil. If the problem stays on the same cylinder and the trigger tests are OK, replace the CDI.

## Tohatsu/Nissan Troubleshooting

### ENGINE HAS A MID-RANGE MISS OR WILL NOT GO OVER 3000 RPM :

1. Verify the warning horn is working properly by grounding the water temperature sensor in the cylinder head (if present).
2. Disconnect the Black/Yellow RPM jumper (connected together with bullet connectors) looping out of and back into the CDI unit. If the miss is still present.
  - A) Disconnect the rectifier/regulator. If the miss is gone, replace the rectifier/regulator.
  - B) Monitor the stator and trigger coils DVA voltage. It should not drop significantly right before the miss becomes apparent.
  - C) Check the output DVA voltage from the CDI unit. If one cylinder has a drop in DVA and the other cylinders do not, replace the CDI unit.
  - D) Perform a high speed shutdown (hold the RPM at the point where the miss is apparent) and shut the engine down using the keyswitch or emergency kill lanyard. Check the spark plugs. If water is present, you may have a crack in the engine block or a leaking head gasket. If there is no water present and one of the sparkplugs is black, swap the ignition coil for that cylinder with another cylinder and see if the problem stays with the coil (replace if it does). Replace the sparkplug if there is no change. Remember, if the engine uses a remote control, the engine has to be running in gear to activate the warning system or ESG (engine protection limiter).
3. If the miss is gone, re-connect the Black/Yellow wires.
4. Disconnect the Light Blue warning wire going into the CDI unit. If the engine performs normally, re-connect the Light Blue wire to the CDI unit.
  - A) Disconnect the Light Blue wire to the oil sensor. Retest engine. If the engine performs normally, replace the oil sensor. If the miss is still present, re-connect the Light Blue wire to the oil sensor.
  - B) Disconnect the Light Blue wire to the water pressure sensor. Retest engine. If the engine performs normally, replace the water pressure sensor sensor.
  - C) Disconnect the Light Blue wire to the overheat temperature sensor. Retest engine. If the engine performs normally, replace the overheat temperature sensor.

### ENGINE WILL NOT SHUT OFF:

Short the Brown stop wire (from CD) to engine ground, if the engine shuts down, check the stop switch and harness.

### 60B, 70B (3 Cylinder)

#### NO SPARK ON ANY CYLINDER:

1. Disconnect the Black and Brown stop wires and retest. If you now have spark, the stop circuit has a fault.
2. Disconnect the regulator/rectifier. If spark returns, replace the regulator/rectifier.
3. Test the stator (exciter) and trigger (pulsar) stator coils as follows:

| Red Lead  | Black Lead | Resistance | DVA Connected                    |
|-----------|------------|------------|----------------------------------|
| Wht/Grn   | Brn/Wht    | 216-324    | 3 V Minimum                      |
| Wht/Grn   | Wht/Yel    |            | 34 V Minimum                     |
| Brn/Wht   | Wht/Yel    | 18-22      | 35 V Minimum                     |
| Wht/Red   | Black      | 160-240    | 4.75 V Minimum                   |
| Wht/Black | Black      | 160-240    | 4.75 V Minimum                   |
| Wht/Blue  | Black      | 160-240    | 4.75 V Minimum                   |
| Blk/Wht   | Black      |            | 135 V Minimum CDI Output to coil |
| Blk/Red   | Black      |            | 135 V Minimum CDI Output to coil |
| Blk/Grn   | Black      |            | 135 V Minimum CDI Output to coil |

### ENGINE HAS A MID-RANGE MISS OR WILL NOT GO OVER 3000 RPM :

1. Verify the warning horn is working properly by grounding the water temperature sensor in the cylinder head (if present).
2. Disconnect the Black/Yellow RPM jumper (connected together with bullet connectors) looping out of and back into the CDI unit. If the miss is still present.
  - A) Disconnect the rectifier/regulator. If the miss is gone, replace the rectifier/regulator.
  - B) Monitor the stator and trigger coils DVA voltage. It should not drop significantly right before the miss becomes apparent.
  - C) Check the output DVA voltage from the CDI unit. If one cylinder has a drop in DVA and the other cylinders do not, replace the CDI unit.

## Tohatsu/Nissan Troubleshooting

- D) Perform a high speed shutdown (hold the RPM at the point where the miss is apparent) and shut the engine down using the keyswitch or emergency kill lanyard. Check the spark plugs. If water is present, you may have a crack in the engine block or a leaking head gasket. If there is no water present and one of the sparkplugs is black, swap the ignition coil for that cylinder with another cylinder and see if the problem stays with the coil (replace if it does). Replace the sparkplug if NC.
3. If the miss is gone, re-connect the Black/Yellow wires.
4. Disconnect the Light Blue warning wire going into the CDI unit. If the engine performs normally, re-connect the Light Blue wire to the CDI unit.
  - A) Disconnect the Light Blue wire to the oil sensor. Retest engine. If the engine performs normally, replace the oil sensor. If the miss is still present, re-connect the Light Blue wire to the oil sensor.
  - B) Disconnect the Light Blue wire to the water pressure sensor. Retest engine. If the engine performs normally, replace the water pressure sensor.
  - C) Disconnect the Light Blue wire to the overheat temperature sensor. Retest engine. If the engine performs normally, replace the overheat temperature sensor.

### NO SPARK ON ONE OR MORE CYLINDERS:

1. Swap the ignition coil from the cylinder not firing to one that does. If the no fire follows the coil, replace it.
2. Disconnect the regulator/rectifier. If the miss is gone, replace the regulator/rectifier.
3. Test the Pulsar coil output and CDI output as follows:

| Red Lead  | Black Lead | Resistance | DVA Connected                    |
|-----------|------------|------------|----------------------------------|
| Wht/Red   | Black      | 160-240    | 4.75 V Minimum                   |
| Wht/Black | Black      | 160-240    | 4.75 V Minimum                   |
| Wht/Blue  | Black      | 160-240    | 4.75 V Minimum                   |
| Blk/Wht   | Black      |            | 135 V Minimum CDI Output to coil |
| Blk/Red   | Black      |            | 135 V Minimum CDI Output to coil |
| Blk/Grn   | Black      |            | 135 V Minimum CDI Output to coil |

### HIGH SPEED MISS:

1. Disconnect the regulator/rectifier. If the miss is gone, replace the regulator/rectifier
2. Perform a high speed shutdown and read the spark plugs. If one sparkplug is black and the others are a tan color, swap the ignition coil to another cylinder. Repeat the test. If the black sparkplug reading follows the coil, replace the coil.

### ENGINE WILL NOT SHUT OFF:

Short the Brown stop wire (from CD) to engine ground, if the engine shuts down, check the stop switch and harness.

## 60C, 70C (3 Cylinder) (With the CU2555 Ignition Pack)

### NO SPARK ON ANY CYLINDER:

1. Disconnect the Black and Brown stop wires and retest. If you now have spark, the stop circuit has a fault.
2. Disconnect the regulator/rectifier. If spark returns, replace the regulator/rectifier.
3. Test the stator (exciter) and trigger (pulsar) stator coils as follows:

| Red Lead  | Black Lead | Resistance | DVA Connected                    |
|-----------|------------|------------|----------------------------------|
| Wht/Grn   | Wht/Yel    | 220-330    | 8 V Minimum                      |
| Wht/Red   | Black      | 152-228    | 4.75 V Minimum                   |
| Wht/Black | Black      | 152-228    | 4.75 V Minimum                   |
| Wht/Blue  | Black      | 152-228    | 4.75 V Minimum                   |
| Blk/Wht   | Black      |            | 190 V Minimum CDI Output to coil |
| Blk/Wht   | Black      |            | 190 V Minimum CDI Output to coil |
| Blk/Wht   | Black      |            | 190 V Minimum CDI Output to coil |

### ENGINE HAS A MID-RANGE MISS OR WILL NOT GO OVER 3000 RPM :

1. Verify the warning horn is working properly by grounding the water temperature sensor in the cylinder head (if present).
2. Disconnect the Black/Yellow RPM jumper (connected together with bullet connectors) looping out of and back into the CDI unit. If the miss is still present.

## Tohatsu/Nissan Troubleshooting

- A) Disconnect the rectifier/regulator. If the miss is gone, replace the rectifier/regulator.
  - B) Monitor the stator and trigger coils DVA voltage. It should not drop significantly right before the miss becomes apparent.
  - C) Check the output DVA voltage from the CDI unit. If one cylinder has a drop in DVA and the other cylinders do not, replace the CDI unit.
  - D) Perform a high speed shutdown (hold the RPM at the point where the miss is apparent) and shut the engine down using the keyswitch or emergency kill lanyard. Check the spark plugs. If water is present, you may have a crack in the engine block or a leaking head gasket. If there is no water present and one of the sparkplugs is black, swap the ignition coil for that cylinder with another cylinder and see if the problem stays with the coil (replace if it does). Replace the sparkplug if NC.
3. If the miss is gone, re-connect the Black/Yellow wires.
  4. Disconnect the Light Blue warning wire going into the CDI unit. If the engine performs normally, re-connect the Light Blue wire to the CDI unit.
    - A) Disconnect the Light Blue wire to the oil sensor. Retest engine. If the engine performs normally, replace the oil sensor. If the miss is still present, re-connect the Light Blue wire to the oil sensor.
    - B) Disconnect the Light Blue wire to the water pressure sensor. Retest engine. If the engine performs normally, replace the water pressure sensor.
    - C) Disconnect the Light Blue wire to the overheat temperature sensor. Retest engine. If the engine performs normally, replace the overheat temperature sensor.

### HIGH SPEED MISS:

1. Disconnect the regulator/rectifier. If the miss is gone, replace the regulator/rectifier
2. Perform a high speed shutdown and read the spark plugs. If one sparkplug is black and the others are a tan color, swap the ignition coil to another cylinder. Repeat the test. If the black sparkplug reading follows the coil, replace the coil.

### ENGINE WILL NOT SHUT OFF:

Short the Brown stop wire (from CD) to engine ground, if the engine shuts down, check the stop switch and harness.

## 60C, 70C (3 Cylinder) (With the F8T20573 Ignition Pack)

### NO SPARK ON ANY CYLINDER:

1. Disconnect the Black and Brown stop wires and retest. If you now have spark, the stop circuit has a fault.
2. Disconnect the regulator/rectifier. If spark returns, replace the regulator/rectifier.
3. Test the stator (exciter) and trigger (pulsar) stator coils as follows:

| Red Lead  | Black Lead | Resistance | DVA Connected                    |
|-----------|------------|------------|----------------------------------|
| Wht/Grn   | Wht/Yel    | 427-600    | 135 V Minimum                    |
| Wht/Red   | Black      | 178-240    | 4.75 V Minimum                   |
| Wht/Black | Black      | 178-240    | 4.75 V Minimum                   |
| Wht/Blue  | Black      | 178-240    | 4.75 V Minimum                   |
| Blk/Wht   | Black      |            | 190 V Minimum CDI Output to coil |

### ENGINE HAS A MID-RANGE MISS OR WILL NOT GO OVER 3000 RPM :

1. Verify the warning horn is working properly by grounding the water temperature sensor in the cylinder head (if present).
2. Disconnect the Black/Yellow RPM jumper (connected together with bullet connectors) looping out of and back into the CDI unit. If the miss is still present.
  - A) Disconnect the rectifier/regulator. If the miss is gone, replace the rectifier/regulator.
  - B) Monitor the stator and trigger coils DVA voltage. It should not drop significantly right before the miss becomes apparent.
  - C) Check the output DVA voltage from the CDI unit. If one cylinder has a drop in DVA and the other cylinders do not, replace the CDI unit.
  - D) Perform a high speed shutdown (hold the RPM at the point where the miss is apparent) and shut the engine down using the keyswitch or emergency kill lanyard. Check the spark plugs. If water is present, you may have a crack in the engine block or a leaking head gasket. If there is no water present and one of the sparkplugs is black, swap the ignition coil for that cylinder with another cylinder and see if the problem stays



## Tohatsu/Nissan Troubleshooting

SPwith the coil (replace if it does). Replace the sparkplug if NC.

3. If the miss is gone, re-connect the Black/Yellow wires.
4. Disconnect the Light Blue warning wire going into the CDI unit. If the engine performs normally, re-connect the Light Blue wire to the CDI unit.
  - A) Disconnect the Light Blue wire to the oil sensor. Retest engine. If the engine performs normally, replace the oil sensor. If the miss is still present, re-connect the Light Blue wire to the oil sensor.
  - B) Disconnect the Light Blue wire to the water pressure sensor. Retest engine. If the engine performs normally, replace the water pressure sensor.
  - C) Disconnect the Light Blue wire to the overheat temperature sensor. Retest engine. If the engine performs normally, replace the overheat temperature sensor.

### HIGH SPEED MISS:

1. Disconnect the regulator/rectifier. If the miss is gone, replace the regulator/rectifier
2. Perform a high speed shutdown and read the spark plugs. If one sparkplug is black and the others are a tan color, swap the ignition coil to another cylinder. Repeat the test. If the black sparkplug reading follows the coil, replace the coil.

### ENGINE WILL NOT SHUT OFF:

Short the Brown stop wire (from CD) to engine ground, if the engine shuts down, check the stop switch and harness.

## 80A, 90A (3 Cylinder) 1992-2000 (3B7061602M)

### NO SPARK ON ANY CYLINDER:

1. Disconnect the Black and Brown stop wires and retest. If you now have spark, the stop circuit has a fault.
2. Disconnect the Yellow and White wires from the Rectifier/Regulator. If spark returns to all cylinders, replace the Rectifier/Regulator.
3. Test the stator (exciter) and trigger (pulsar) stator coils as follows:

| Red Lead | Black Lead | Resistance | DVA Connected                    |
|----------|------------|------------|----------------------------------|
| White    | Wht/Yel    | 175-241    | 135 V Minimum                    |
| Wht/Red  | Black      | 166-230    | 4.75 V Minimum                   |
| Wht/Blk  | Black      | 166-230    | 4.75 V Minimum                   |
| Wht/Blue | Black      | 166-230    | 4.75 V Minimum                   |
| Blk/Wht  | Black      |            | 190 V Minimum CDI Output to coil |
| Blk/Red  | Black      |            | 190 V Minimum CDI Output to coil |
| Blk/Grn  | Black      |            | 190 V Minimum CDI Output to coil |

### ENGINE HAS A MID-RANGE MISS OR WILL NOT GO OVER 3000 RPM :

1. Verify the warning horn is working properly by grounding the water temperature sensor in the cylinder head (if present).
2. Disconnect the Black/Yellow RPM jumper (connected together with bullet connectors) looping out of and back into the CDI unit. If the miss is still present.
  - A) Disconnect the rectifier/regulator. If the miss is gone, replace the rectifier/regulator.
  - B) Monitor the stator and trigger coils DVA voltage. It should not drop significantly right before the miss becomes apparent.
  - C) Check the output DVA voltage from the CDI unit. If one cylinder has a drop in DVA and the other cylinders do not, replace the CDI unit.
  - D) Perform a high speed shutdown (hold the RPM at the point where the miss is apparent) and shut the engine down using the keyswitch or emergency kill lanyard. Check the spark plugs. If water is present, you may have a crack in the engine block or a leaking head gasket. If there is no water present and one of the sparkplugs is black, swap the ignition coil for that cylinder with another cylinder and see if the problem stays with the coil (replace if it does). Replace the sparkplug if NC.
3. If the miss is gone, re-connect the Black/Yellow wires.
4. Disconnect the Light Blue warning wire going into the CDI unit. If the engine performs normally, re-connect the Light Blue wire to the CDI unit.
  - A) Disconnect the Light Blue wire to the oil sensor. Retest engine. If the engine performs normally, replace the oil sensor. If the miss is still present, re-connect the Light Blue wire to the oil sensor.
  - B) Disconnect the Light Blue wire to the water pressure sensor. Retest engine. If the engine performs normally,

## Tohatsu/Nissan Troubleshooting

replace the water pressure sensor.

- C) Disconnect the Light Blue wire to the overheat temperature sensor. Retest engine. If the engine performs normally, replace the overheat temperature sensor.

### NO SPARK ON ONE OR MORE CYLINDERS:

1. Swap the ignition coil from the cylinder not firing to one that does. If the no fire follows the coil, replace it.
2. Disconnect the Yellow and White wires from the Rectifier/Regulator. If the miss is gone, replace the regulator/rectifier.
3. Test the CDI output as follows:

| Red Lead | Black Lead | DVA Connected                    |
|----------|------------|----------------------------------|
| Blk/Wht  | Black      | 190 V Minimum CDI Output to coil |
| Blk/Red  | Black      | 190 V Minimum CDI Output to coil |
| Blk/Grn  | Black      | 190 V Minimum CDI Output to coil |

4. Test the trigger (pulsar) stator coils as follows:

| Red Lead | Black Lead | Resistance | DVA Connected  |
|----------|------------|------------|----------------|
| Wht/Red  | Black      | 166-230    | 4.75 V Minimum |
| Wht/Blk  | Black      | 166-230    | 4.75 V Minimum |
| Wht/Blue | Black      | 166-230    | 4.75 V Minimum |

5. Disconnect the Yellow and White wires from the Rectifier/Regulator. If the miss is gone, replace the regulator/rectifier.

### HIGH SPEED MISS:

1. Disconnect the regulator/rectifier. If the miss is gone, replace the regulator/rectifier
2. Perform a high speed shutdown and read the spark plugs. If one sparkplug is black and the others are a tan color, swap the ignition coil to another cylinder. Repeat the test. If the black sparkplug reading follows the coil, replace the coil.

### ENGINE WILL NOT SHUT OFF:

Short the Brown stop wire (from CD) to engine ground, if the engine shuts down, check the stop switch and harness.

## 115A2, 120A 2, 140A 2

### NO SPARK ON ANY CYLINDER:

1. Disconnect the Black and Brown stop wires and retest. If you now have spark, the stop circuit has a fault.
2. Disconnect the Black/White wires from the Rectifier/Regulator. If spark returns to all cylinders, replace the Rectifier/Regulator.
3. Test the stator (exciter) and trigger (pulsar) stator coils as follows:

| Red Lead   | Black Lead | Resistance | DVA Connected  |
|------------|------------|------------|----------------|
| Wht/Green  | Orange     | 255-350    | 135 V Minimum  |
| Wht/Red    | Black      | 187-260    | 4.75 V Minimum |
| Wht/Black  | Black      | 187-260    | 4.75 V Minimum |
| Wht/Blue   | Black      | 187-260    | 4.75 V Minimum |
| Wht/Yellow | Black      | 187-260    | 4.75 V Minimum |

### NO SPARK ON ONE OR MORE CYLINDERS:

1. Swap the ignition coil from the cylinder not firing to one that does. If the no fire follows the coil, replace it.
2. Disconnect the Yellow and White wires from the Rectifier/Regulator. If the miss is gone, replace the regulator/rectifier.
3. Test the CDI output as follows:

| Red Lead | Black Lead | DVA Connected                    |
|----------|------------|----------------------------------|
| Blk/Wht  | Black      | 190 V Minimum CDI Output to coil |
| Blk/Red  | Black      | 110 V Minimum CDI Output to coil |
| Blk/Grn  | Black      | 110 V Minimum CDI Output to coil |
| Blk/Blue | Black      | 110 V Minimum CDI Output to coil |

4. Test the trigger (pulsar) stator coils as follows:

| Red Lead   | Black Lead | Resistance | DVA Connected  |
|------------|------------|------------|----------------|
| Wht/Red    | Black      | 187-260    | 4.75 V Minimum |
| Wht/Blk    | Black      | 187-260    | 4.75 V Minimum |
| Wht/Blue   | Black      | 187-260    | 4.75 V Minimum |
| Wht/Yellow | Black      | 187-260    | 4.75 V Minimum |

## **Tohatsu/Nissan Troubleshooting**

### **ENGINE WILL NOT GO OVER 1500 RPM :**

1. Disconnect the regulator/rectifier. If the miss is gone, replace the regulator/rectifier.
1. Disconnect the Black/Yellow RPM jumper (connected together with bullet connectors) looping out of and back into the CDI unit.
2. If the miss is still present, verify the Red/Yellow wire is connected securely and has a good connection, both at the CDI unit and at the keyswitch (it must have switched 12 VDC at the red/yellow wire going into the CD). If the Red/Yellow wire connections are good, replace the CDI unit.
3. Replace the CDI unit.
4. If the miss is gone with the Black/Yellow wires disconnected, re-connect the Black/Yellow wires.
5. Disconnect the Light Blue warning wire going into the CDI unit. If the engine performs normally, re-connect the Light Blue wire to the CDI unit.
  - A) Disconnect Light Blue wire to the oil sensor. Retest engine. If the engine performs normally, replace the oil sensor. If the miss is still present, re-connect the Light Blue wire to the oil sensor.
  - B) Disconnect Light Blue wire to the water pressure sensor. Retest engine. If the engine performs normally, replace the water pressure sensor.
  - C) Disconnect Light Blue wire to the overheat temperature sensor. Retest engine. If the engine performs normally, replace the overheat temperature sensor.

### **ENGINE HAS A MID-RANGE MISS OR WILL NOT GO OVER 3000 RPM :**

1. Verify the warning horn is working properly by grounding the water temperature sensor in the cylinder head (if present).
2. Disconnect the Black/Yellow RPM jumper (connected together with bullet connectors) looping out of and back into the CDI unit. If the miss is still present.
  - A) Disconnect the rectifier/regulator. If the miss is gone, replace the rectifier/regulator.
  - B) Monitor the stator and trigger coils DVA voltage. It should not drop significantly right before the miss becomes apparent.
  - C) Check the output DVA voltage from the CDI unit. If one cylinder has a drop in DVA and the other cylinders do not, replace the CDI unit.
  - D) Perform a high speed shutdown (hold the RPM at the point where the miss is apparent) and shut the engine down using the keyswitch or emergency kill lanyard. Check the spark plugs. If water is present, you may have a crack in the engine block or a leaking head gasket. If there is no water present and one of the sparkplugs is black, swap the ignition coil for that cylinder with another cylinder and see if the problem stays with the coil (replace if it does). Replace the sparkplug if NC.
3. If the miss is gone, re-connect the Black/Yellow wires.
4. Disconnect the Light Blue warning wire going into the CDI unit. If the engine performs normally, re-connect the Light Blue wire to the CDI unit.
  - A) Disconnect Light Blue wire to the oil sensor. Retest engine. If the engine performs normally, replace the oil sensor. If the miss is still present, re-connect the Light Blue wire to the oil sensor.
  - B) Disconnect Light Blue wire to the water pressure sensor. Retest engine. If the engine performs normally, replace the water pressure sensor.
  - C) Disconnect Light Blue wire to the overheat temperature sensor. Retest engine. If the engine performs normally, replace the overheat temperature sensor.

### **HIGH SPEED MISS:**

1. Disconnect the regulator/rectifier. If the miss is gone, replace the regulator/rectifier
2. Perform a high speed shutdown and read the spark plugs. If one sparkplug is black and the others are a tan color, swap the ignition coil to another cylinder. Repeat the test. If the black sparkplug reading follows the coil, replace the coil. NOTE: If the ignition coil tests as defective, check the resistor boot (you should read between 4 and 6 K ohms through the boot).

### **ENGINE WILL NOT SHUT OFF:**

Short the Brown stop wire (from CD) to engine ground, if the engine shuts down, check the stop switch and harness.

# Tohatsu/Nissan Troubleshooting

## NISSAN/TOHATSU

### TLDI (Tohatsu Low Pressure Direct Injected) Engines

Service Notes: Please use the Factory recommended spark plug specified and gapped at the correct setting (listed on the engine decal).

The maximum spark timing is controlled by the ignition ECU and is non-adjustable.

SERVICE NOTE: BATTERY voltage is critical to the engine running correctly. The use of a under-sized battery can cause problems with the engine performance. It is HIGHLY recommended a 1000 CCA battery be used with these engines.

### GENERAL

NOTICE: If the following information does not help resolve the problem, please refer the customer to a Certified Tohatsu/Nissan Dealer for service.

#### ENGINE HAS SPARK BUT WILL NOT RUN:

1. Check fuel pressure. If low, check to see if the high pressure fuel pump is running when you turn on the keyswitch. 40-70 HP Model's A & B (2 Star) should be approximately 80 PSI Air and 90 PSI Fuel. 40-50 HP Model B2, 75-90 HP Model C and 115 Model A (3 Star) should be approximately 94 PSI Air and 104 PSI Fuel. If the fuel pressure is low and the air pressure is OK, the problem is usually in the fuel circuit. Check the fuel supply to the vapor separator, high pressure fuel pump and high pressure fuel lines.
2. If the fuel and air pressure are both low, disconnect the air filter for the compressor and see if the air pressure is now correct and the engine will run. If so, replace the air filter.
3. If the air and fuel pressure remain low, disconnect the air line from the compressor and pressurize the air rail using shop air, regulated at 80 PSI (90 PSI for the 3 Star engines). If the engine runs, replace the compressor.

#### ENGINE WILL NOT THROTTLE UP- WILL ONLY IDLE:

1. Re-set the TPS. If someone has tried to start the engine in gear for 25 times or more, the ECU will lock out anything above an idle until the TPS (Throttle Position Sensor) is re-set.
2. Check the air and fuel pressures. 40-70 HP Model A & B should be 80 PSI Air and 90 PSI Fuel. 40-50 HP Model B2, 75-90 HP Model C and 115 Model A, should be at 94 PSI Air and 104 PSI Fuel.
3. Check the engine temperature and temperature sensor. If the engine is over-heating (over 203 degrees) or if the temperature sensor is defective, the engine will be in a forced idle mode.
4. Check to see if both #1 & #2 TPS sensors are defective. The TPS sensors must be replaced as a SET.
5. On engines with an electric oil pump, check to see if the oil pump is operating.

#### NO SPARK OR WEAK SPARK ON ANY CYLINDER:

1. Disconnect the Brown stop wire from the harness. Retest. If the engine's ignition now has spark, the stop circuit has a fault. Check the key switch, harness and shift switch.
2. Inspect the spark plug wires, boots and spark plugs. Check for chafing on the wiring and harnesses.
3. Inspect and clean all engine ground connections and power connections. Remember, the engine MUST HAVE battery power to the engine's ignition system to run.
4. For models 40A, 50A, 70A and 90A ONLY, check the Stator as follows:

| WIRE      | READ TO      | RESISTANCE   |
|-----------|--------------|--------------|
| White/Red | White/Blue   | 438-592 Ohms |
| Green     | White/Yellow | 61-82.6 Ohms |

NOTE: B and C models are INDUCTIVE systems running on battery power.

#### NO SPARK OR WEAK SPARK ON ONE CYLINDER:

1. Inspect the spark plug wires, boots and spark plugs. Check for chafing on the wiring and harnesses.
2. Clean and inspect coil Black ground wire connection to engine ground.
3. If the cylinders are only misfiring above an idle, connect an inductive RPM meter to all cylinders and try to isolate the problem cylinders.

## **Tohatsu/Nissan Troubleshooting**

4. For models 40, 50, 70 and 90A, check the Stator as follows:

| <u>WIRE</u> | <u>READ TO</u> | <u>RESISTANCE</u> |
|-------------|----------------|-------------------|
| White/Red   | White/Blue     | 438-592 Ohms      |
| Green       | White/Yellow   | 61-82.6 Ohms      |

5. Check the ignition coil resistance as given below:

| <u>WIRE</u>     | <u>READ TO</u> | <u>RESISTANCE</u> |
|-----------------|----------------|-------------------|
| Black/White     | Engine GND     | 0.9-1.2           |
| Spark plug wire | Engine GND     | 12.25-12.75K      |

### **TIMING FLUCTUATES:**

Service Notes: It is normal for timing to fluctuate 1 to 2° @ idle.

1. Clean and inspect all ground connections.
2. Check the Crank Position Sensor air gap. Should be 0.020-0.036 inches or 0.5 mm -0.9 mm.
3. Check the Crank Position Sensor resistance as given below:

| <u>WIRE</u> | <u>READ TO</u> | <u>RESISTANCE</u> |
|-------------|----------------|-------------------|
| Green/Red   | Blue/Black     | 451-611           |

4. Check the Throttle Position Sensor and the Engine Temperature Sensor.
5. Check the ECU.

### **TIMING WILL NOT ADVANCE:**

1. Check the Crank Position Sensor and the Throttle Position Sensor.
2. Check the ECU.

### **ENGINE MISSES AT HIGH RPM:**

1. Check for correct spark plugs (See data sticker on engine).
2. Check the Crank Position Sensor.
3. Check the battery voltage.
4. Check the ECU.
5. For models 40, 50, 70 and 90A, check the Stator as follows:

| <u>WIRE</u> | <u>READ TO</u> | <u>RESISTANCE</u> |
|-------------|----------------|-------------------|
| White/Red   | White/Blue     | 438-592 Ohms      |
| Green       | White/Yellow   | 61-82.6 Ohms      |

### **ENGINE HARD TO START WHEN COLD:**

1. Check the Engine Temperature Sensor and the battery voltage while cranking (battery voltage should remain over 10 volts). Remember, a 1000 CCA battery is recommended for the direct injected engines.
2. Check and clean the battery cable connections, both on the engine and the battery.
3. Check the Harness for loose connections between ECU and Starter Solenoid.

### **ENGINE MISSES @ LOW RPM, BUT RUNS SMOOTH @ HIGH RPM:**

1. Check the Harness for loose connections between ECU and Ignition Modules.
2. Test the battery and battery connections. Try another battery and see if the problem goes away.

### **ENGINE STARTS HARD WHEN HOT:**

1. Check the Enrichment Solenoid (Carbureted engines).
2. Check the Engine Temperature Sensor and the Crank Position Sensor.

### **ENGINE WILL NOT RUN OVER 3000 RPM AND IS NOT OVERHEATING:**

1. Check the Engine Temperature Sensor and the Throttle Position Sensor.
2. Check the ECU, Map Sensor and Shift Interrupt Switch.
3. For models 40, 50, 70 and 90A, check the Stator as follows:

| <u>WIRE</u> | <u>READ TO</u> | <u>RESISTANCE</u> |
|-------------|----------------|-------------------|
| White/Red   | White/Blue     | 438-592 Ohms      |
| Green       | White/Yellow   | 61-82.6 Ohms      |



# Yamaha Troubleshooting

## Yamaha

### 2 Stroke Ignitions One and Two Cylinder Engines 1984-2005

#### 2 HP 1995-2002

##### NO SPARK:

1. Connect a spark tester (gapped at about 3/8") to the spark plug wire and check to spark. If the engine has spark on a spark tester but does not appear to have spark on the spark plug, replace the spark plug and retest.
2. Disconnect the White stop wire and retest. If the ignition system now has spark, the stop circuit has a problem.
3. Inspect and clean all engine and ignition ground connections.
4. Check the charge coil resistance and DVA voltage:

| Check From: | Check To: | Ohms Reading: | DVA Connected |
|-------------|-----------|---------------|---------------|
| Brown       | Black     | 281 to 422    | 150 V         |

5. Check the ignition packs output voltage, resistance of the ignition coil's primary and secondary windings.

| Check From:    | Check To: | Ohms Reading:                | DVA Connected |
|----------------|-----------|------------------------------|---------------|
| Orange         | Black     | -                            | 130 V         |
| Orange         | Black     | 0.08 to 0.12                 |               |
| Spark Plug Cap | Black     | 2.56K (2080) to 3.84K (3840) |               |

##### HAS SPARK BUT WILL NOT RUN:

1. Make sure the engine is getting fuel to the combustion chamber (make sure there is no water or residue in the carburetor).
2. Check flywheel shear key to make sure it has not sheared due to backfiring or impact on the propeller.
3. Check flywheel magnet to make sure it has broken loose and moved, causing a timing shift.
4. Check spark plug for presence of water, indicating a possible cracked block or blown head gasket.
5. Check compression, carburetor, reeds and do a cylinder leak down test.

##### WILL NOT STOP (KILL):

1. Disconnect the White wire from the CD Module.
2. Short the White wire from the CD Module to engine ground. If the engine stops, the problem is in the stop circuit. If the engine continues to run with the White wire shorted to engine ground, replace the defective CD Module.

#### 3 HP 1988-2002

##### NO SPARK:

1. Connect a spark tester (gapped at about 3/8") to the spark plug wire and check to spark. If the engine has spark on a spark tester but does not appear to have spark on the spark plug, replace the spark plug and retest.
2. Disconnect the White stop wire and retest. If the ignition system now has spark, the stop circuit has a problem.
3. Check the resistance of the ignition coil's primary winding. You should read between 0.08 to 0.12 ohms from the Orange wire to the Black wire from the ignition coil.
4. Inspect and clean all engine and ignition ground connections.
5. Check the resistance and DVA voltage of the charge coil, trigger coils and ignition coil.

| Function           | Check From:         | Check To: | Ohms Reading:                | DVA Connected |
|--------------------|---------------------|-----------|------------------------------|---------------|
| Charge Coil        | Brown               | Black     | 250-300                      | 150 V Minimum |
| High Speed Trigger | Red/White (88-92)   | Black     | 30-36                        | 2 V Minimum   |
| High Speed Trigger | White/Red (93-02)   | Black     | 30-36                        | 2 V Minimum   |
| Low Speed Trigger  | Green/White (88-92) | Black     | 279-341                      | 1 V Minimum   |
| Low Speed Trigger  | White/Black (93-02) | Black     | 279-341                      | 1 V Minimum   |
| Pack Output        | Orange              | Black     | 0.08 to 0.12                 | 150 V Minimum |
| Ignition Coil      | Spark Plug Cap      | Black     | 2.08K (2080) to 3.12K (3120) |               |

##### HAS SPARK BUT WILL NOT RUN:

1. Make sure the engine is getting fuel to the combustion chamber (make sure there is no water or residue in the carburetor).
2. Check flywheel shear key to make sure it has not sheared due to backfiring or impact on the propeller.
3. Check flywheel magnet to make sure it has not broken loose and moved, causing a timing shift.

## Yamaha Troubleshooting

4. Check spark plug for presence of water, indicating a possible cracked block or blown head gasket.
5. Check compression, carburetor, reeds and do a cylinder leak down test.
6. Check the Triggers as follows as a defective trigger can cause timing variance:

| Function           | Check From:         | Check To: | Ohms Reading: | DVA Connected |
|--------------------|---------------------|-----------|---------------|---------------|
| High Speed Trigger | Red/White (88-92)   | Black     | 30-36         | 2 V Minimum   |
| High Speed Trigger | White/Red (93-02)   | Black     | 30-36         | 2 V Minimum   |
| Low Speed Trigger  | Green/White (88-92) | Black     | 280-340       | 1 V Minimum   |
| Low Speed Trigger  | White/Black (93-02) | Black     | 280-340       | 1 V Minimum   |

### WILL NOT STOP (KILL):

Short the White wire from the CD Module to engine ground. If the engine stops, the problem is in the stop circuit. If the engine continues to run with the White wire shorted to engine ground, replace the defective CD Module.

### 4 HP 1984-1999, 5 HP 1984-1985, 1994-2002

**6E0-85540-71-00/117-6E0-71**

### NO SPARK:

1. Connect a spark tester (gapped at about 3/8" ) to the spark plug wire and check to spark. If the engine has spark on a spark tester but does not appear to have spark on the spark plug, replace the spark plug and retest.
2. Disconnect the White stop wire and retest. If the ignition system now has spark, the stop circuit has a problem.
3. Check the resistance of the ignition coil's primary winding. You should read between 0.08 to 0.12 ohms from the Orange wire to the Black wire from the ignition coil.
4. Inspect and clean all engine and ignition ground connections.
5. Check the resistance and DVA voltage of the charge coil, trigger coils and ignition coil.

| Function           | Check From:         | Check To: | Ohms Reading:                            | DVA Connected |
|--------------------|---------------------|-----------|--|---------------|
| Charge Coil        | Brown               | Black     | 250-300                                  | 150 V Minimum |
| High Speed Trigger | Red/White (88-92)   | Black     | 30-36                                    | 2 V Minimum   |
| High Speed Trigger | White/Red (93-02)   | Black     | 30-36                                    | 2 V Minimum   |
| Low Speed Trigger  | Green/White (88-92) | Black     | 280-340                                  | 1 V Minimum   |
| Low Speed Trigger  | White/Black (93-02) | Black     | 280-340                                  | 1 V Minimum   |
| Pack Output        | Orange              | Black     | 0.08 to 0.12                             | 150 V Minimum |
| Ignition Coil      | Spark Plug Cap      | Black     | 2.08K (2080) to 3.12K (3120) (1988-1991) |               |
| Ignition Coil      | Spark Plug Cap      | Black     | 2.5K (2500) to 3.7K (3700) (1992-1999)   |               |

### HAS SPARK BUT WILL NOT RUN:

1. Make sure the engine is getting fuel to the combustion chamber (make sure there is no water or residue in the carburetor).
2. Check flywheel shear key to make sure it has not sheared due to backfiring or impact on the propeller.
3. Check flywheel magnet to make sure it has not broken loose and moved, causing a timing shift.
4. Check spark plug for presence of water, indicating a possible cracked block or blown head gasket.
5. Check compression, carburetor, reeds and do a cylinder leak down test.
6. Check the Triggers as follows as a defective trigger can cause timing variance:

| Function           | Check From:         | Check To: | Ohms Reading: | DVA Connected |
|--------------------|---------------------|-----------|---------------|---------------|
| High Speed Trigger | White/Red (93-02)   | Black     | 30-36         | 2 V Minimum   |
| Low Speed Trigger  | Green/White (88-92) | Black     | 280-340       | 1 V Minimum   |

### WILL NOT STOP (KILL):

1. Disconnect the White wire from the CD Module.
2. Short the White wire from the CD Module to engine ground. If the engine stops, the problem is in the stop circuit. If the engine continues to run with the White wire shorted to engine ground, replace the defective CD Module.

### 6 and 8 HP 1986-2009

**696-85540-12-00/117-696-12**

### NO SPARK ON ANY CYLINDER:

1. Connect a spark tester (gapped at about 3/8" ) to the spark plug wire and check to spark. If the engine has spark on a spark tester but does not appear to have spark on the spark plug, replace the spark plug and retest.

## **Yamaha Troubleshooting**

2. Disconnect the White stop wire and retest. If the ignition system now has spark, the stop circuit has a problem.
3. Inspect and clean all engine and ignition ground connections.
4. Check the resistance and DVA voltage of the charge coil, trigger coils and ignition coil.

| Check From:      | Check To:        | Ohms Reading:              | DVA Connected |
|------------------|------------------|----------------------------|---------------|
| White/Red        | Black            | 82 to 122                  | 2.5 V Minimum |
| Brown            | Black            | 81-99                      | 110 V Minimum |
| Orange           | Black            | 0.12 to 0.18               | 110 V Minimum |
| Spark Plug Cap 1 | Spark Plug Cap 2 | 2.8K (2800) to 4.2K (4200) |               |

### **HAS SPARK BUT WILL NOT RUN:**

1. Make sure the engine is getting fuel to the combustion chamber (make sure there is no water or residue in the carburetor).
2. Check flywheel shear key to make sure it has not sheared due to backfiring or impact on the propeller.
3. Check flywheel magnet to make sure it has not broken loose and moved, causing a timing shift.
4. Check spark plug for presence of water, indicating a possible cracked block or blown head gasket.
5. Check compression, carburetor, reeds and do a cylinder leak down test.
6. Check the Triggers as follows as a defective trigger can cause timing variance:

| Check From: | Check To: | Ohms Reading: | DVA Reading:  |
|-------------|-----------|---------------|---------------|
| White/Red   | Black     | 90-110        | 2.5 V Minimum |

**WILL NOT STOP (KILL):** Short the White wire from the CD Module to engine ground. If the engine stops firing, the problem is in the stop circuit. If the engine continues to run with the White wire shorted to engine ground, replace the defective CD Module.

### **ONLY HAS SPARK ON ONE CYLINDER:**

If only one cylinder has spark, replace the ignition coil.

## **9.9S and 15S HP 1984-1995 695-85540-11-00/117-695-11**

### **NO SPARK ON ANY CYLINDER:**

1. Disconnect the White stop wire and retest. If the ignition system now has spark, the stop circuit has a problem.
2. Inspect and clean all engine and ignition ground connections.
3. Check the resistance and DVA voltage of the charge coil, trigger coils and ignition coil.

| Check From:      | Check To:        | Ohms Reading:               | DVA Connected |
|------------------|------------------|-----------------------------|---------------|
| Brown            | Black            | 81-99                       | 110 V Minimum |
| White/Red        | Black            | 90-112                      | 2 V Minimum   |
| Orange           | Black            | 0.12 to 0.18                | 110 V Minimum |
| Spark Plug Cap 1 | Spark Plug Cap 2 | 3.25K (3250) to 3.8K (3800) |               |

### **NO SPARK ON ONE CYLINDER:**

If only one cylinder has spark, replace the ignition coil.

### **HAS SPARK BUT WILL NOT RUN:**

1. Make sure the engine is getting fuel to the combustion chamber (make sure there is no water or residue in the carburetor).
2. Check the fuel in the carburetor. Check to see if a very high ethanol content is present. If so, purge the fuel system with fresh fuel and see if the engine will start.
3. Check the fuel pressure AT THE CARBURETOR. You should see over 2 PSI. Check fuel lines for inner wall breakdown and wall collapse.
4. Check flywheel shear key to make sure it has not sheared due to backfiring or impact on the propeller.
5. Check flywheel magnet to make sure it has not broken loose and moved, causing a timing shift.
6. Check spark plug for presence of water, indicating a possible cracked block or blown head gasket.
7. Check compression, carburetor, reeds and do a cylinder leak down test.
8. Check the Triggers as follows as a defective trigger can cause timing variance:

| Check From:                    | Check To: | Ohms Reading: | DVA Reading: |
|--------------------------------|-----------|---------------|--------------|
| White/Red (High Speed Trigger) | Black     | 90 to 112     | 2 V Minimum  |

## Yamaha Troubleshooting

### WILL NOT STOP (KILL):

1. Disconnect the White wire from the CD Module.
2. Short the White wire from the CD Module to engine ground. If the engine stops, the problem is in the stop circuit. If the engine continues to run with the White wire shorted to engine ground, replace the defective CD Module.

### 9.9 HP 1996-2005

### 15 HP 1996-2009

### 63V-85540-01-00

### NO SPARK ON ANY CYLINDER:

1. Disconnect the White stop wire and retest. If the ignition system now has spark, the stop circuit has a problem.
2. Inspect and clean all engine and ignition ground connections.
3. Check the resistance and DVA voltage of the charge coil, trigger coils and ignition coil.

| Check From:              | Check To:       | Ohms Reading:                | DVA Connected |
|--------------------------|-----------------|------------------------------|---------------|
| White/Red                | Black           | 352 to 528                   | 2.5 V Minimum |
| Brown (Charge Coil)      | Blue            | 238 to 372                   | 200 V Minimum |
| Black/Orange (Top Cyl)   | Black (Eng Gnd) | N/A                          | 170 V Minimum |
| Black/White (Bottom Cyl) | Black (Eng Gnd) | N/A                          | 170 V Minimum |
| Orange                   | Black           | 0.04 to 0.08                 |               |
| Spark Plug Cap 1         | Engine Ground   | 1.89K (1890) to 2.31K (2310) |               |
| Spark Plug Cap 2         | Engine Ground   | 1.89K (1890) to 2.31K (2310) |               |

### NO SPARK ON ONE CYLINDER:

1. Check the resistance of the ignition coil.
 

| Check From:      | Check To:     | Ohms Reading:                |
|------------------|---------------|------------------------------|
| Orange           | Black         | 0.04 to 0.08                 |
| Spark Plug Cap 1 | Engine Ground | 1.89K (1890) to 2.31K (2310) |
2. Swap the ignition coil not firing with the one that is firing. If the problem stays with the same coil, replace it. If the problem stays on the same cylinder, replace the ignition pack.
3. Inspect the flywheel to see if both trigger tabs are still on it.

### HAS SPARK BUT WILL NOT RUN:

1. Make sure the engine is getting fuel to the combustion chamber (make sure there is no water or residue in the carburetor).
2. Check flywheel shear key to make sure it has not sheared due to backfiring or impact on the propeller.
3. Check flywheel magnet to make sure it has not broken loose and moved, causing a timing shift.
4. Check spark plug for presence of water, indicating a possible cracked block or blown head gasket.
5. Check compression, carburetor, reeds and do a cylinder leak down test.
6. Check the fuel in the carburetor. Check to see if a very high ethanol content is present. . If so, purge the fuel system with fresh fuel and see if the engine will start.
7. Check the fuel pressure AT THE CARBURETOR. You should see over 2 PSI. Check fuel lines for inner wall breakdown and wall collapse.
8. Check the Triggers as follows as a defective trigger can cause timing variance:

| Check From: | Check To: | Ohms Reading: | DVA Reading:  |
|-------------|-----------|---------------|---------------|
| White/Red   | Black     | 396 to 484    | 2.5 V Minimum |

### WILL NOT STOP (KILL):

1. Disconnect the White wire from the CD Module.
2. Short the White wire from the CD Module to engine ground. If the engine stops, the problem is in the stop circuit. If the engine continues to run with the White wire shorted to engine ground, replace the defective CD Module.

# Yamaha Troubleshooting

**20 HP 1996-1997 (2 CYL)  
25 HP 1996-2009 (2 CYL)  
6L2-85540-23-00**

**NO SPARK:**

1. Disconnect the White stop wire and retest. If the ignition system now has spark, the stop circuit has a problem.
2. Inspect and clean all engine and ignition ground connections.
3. Check the resistance of the ignition coil.

| Check From:      | Check To:     | Ohms Reading:                |
|------------------|---------------|------------------------------|
| Spark Plug Cap 1 | Engine Ground | 2.72K (2720) to 3.68K (3680) |
| Spark Plug Cap 2 | Engine Ground | 2.72K (2720) to 3.68K (3680) |

4. Check the Resistance and DVA Voltage of the CDI, Stator and Triggers as follows:

| Check From:              | Check To:       | Ohms Reading: | DVA Reading                      |
|--------------------------|-----------------|---------------|----------------------------------|
| White/Red                | Black           | 277 to 415    | 5.5 V @ cranking/ 15 V @ 1500RPM |
| White/Black              | Black           | 277 to 415    | 5.5 V @ cranking/ 15 V @ 1500RPM |
| Brown (Charge Coil)      | Blue            | 304 to 456    | 125 V @ cranking/125 V @ 1500RPM |
| Black/Orange (Top Cyl)   | Black (Eng Gnd) | 0.18 to 0.24  | 105 V @ cranking/110 V @ 1500RPM |
| Black/White (Bottom Cyl) | Black (Eng Gnd) | 0.18 to 0.24  | 105 V @ cranking/110 V @ 1500RPM |

**HAS SPARK BUT WILL NOT RUN:**

1. Make sure the engine is getting fuel to the combustion chamber (make sure there is no water or residue in the carburetor).
2. Check flywheel shear key to make sure it has not sheared due to backfiring or impact on the propeller.
3. Check flywheel magnet to make sure it has not broken loose and moved, causing a timing shift.
4. Check spark plug for presence of water, indicating a possible cracked block or blown head gasket.
5. Check compression, carburetor, reeds and do a cylinder leak down test.
6. Check the Triggers as follows as a defective trigger can cause timing variance:

| Check From: | Check To: | Ohms Reading: | DVA Reading                     |
|-------------|-----------|---------------|---------------------------------|
| White/Red   | Black     | 277 to 415    | 5.5 V @ cranking/15 V @ 1500RPM |
| White/Black | Black     | 277 to 415    | 5.5 V @ cranking/15 V @ 1500RPM |

**NO SPARK ON ONE CYLINDER:**

Check the Resistance and DVA Voltage of the CDI, Stator and Triggers as follows:

| Check From:              | Check To:       | Ohms Reading: | DVA Reading                      |
|--------------------------|-----------------|---------------|----------------------------------|
| White/Red                | Black           | 277 to 415    | 5.5 V @ cranking/ 15 V @ 1500RPM |
| White/Black              | Black           | 277 to 415    | 5.5 V @ cranking/ 15 V @ 1500RPM |
| Brown (Charge Coil)      | Blue            | 304 to 456    | 125 V @ cranking/125 V @ 1500RPM |
| Black/Orange (Top Cyl)   | Black (Eng Gnd) | 0.18 to 0.24  | 105 V @ cranking/110 V @ 1500RPM |
| Black/White (Bottom Cyl) | Black (Eng Gnd) | 0.18 to 0.24  | 105 V @ cranking/110 V @ 1500RPM |
| Ignition Coil Secondary  | Black (Eng Gnd) | 2.56K – 3.84K |                                  |

**WILL NOT STOP (KILL):**

1. Disconnect the White wire from the CD Module.
2. Short the White wire from the CD Module to engine ground. If the engine stops, the problem is in the stop circuit. If the engine continues to run with the White wire shorted to engine ground, replace the defective CD Module.

**WILL NOT ACCELERATE OVER 2000 RPM:**

1. Disconnect the Pink wire from the CDI and retest. If the engine now runs normally, check the head temperature sensor and the oil tank sensor.
2. Disconnect the White wire from the CD Module and retest. If the engine runs normally, the harness could have a intermittent short.



## Yamaha Troubleshooting

**25 HP (2 CYL) 1984-1987**  
**30 HP (2 Cyl) 1984-1986**  
**C30 HP (2 Cyl) 1989-1992**  
**689-85540-21-00**

### NO SPARK:

1. Disconnect the White stop wire and retest. If the ignition system now has spark, the stop circuit has a problem.
2. Inspect and clean all engine and ignition ground connections.
3. Check the resistance of the ignition coil.

| Check From:      | Check To:        | Ohms Reading:              |
|------------------|------------------|----------------------------|
| Spark Plug Cap 1 | Spark Plug Cap 2 | 2.8K (2800) to 4.2K (4200) |

4. Check the Resistance and DVA Voltage of the CDI, Stator and Triggers as follows:

| Check From:         | Check To:       | Ohms Reading: | DVA Reading:     |
|---------------------|-----------------|---------------|------------------|
| White/Red           | Black           | 12 to 16      | 5 V @ cranking   |
| Brown (Charge Coil) | Black           | 120 to 160    | 190 V @ cranking |
| Black/White         | Black (Eng Gnd) | 0.18 to 0.24  | 210 V @ cranking |

### HAS SPARK BUT WILL NOT RUN:

1. Make sure the engine is getting fuel to the combustion chamber (make sure there is no water or residue in the carburetor).
2. Check flywheel shear key to make sure it has not sheared due to backfiring or impact on the propeller.
3. Check flywheel magnet to make sure it has not broken loose and moved, causing a timing shift.
4. Check spark plug for presence of water, indicating a possible cracked block or blown head gasket.
5. Check compression, carburetor, reeds and do a cylinder leak down test.
6. Check the Triggers as follows as a defective trigger can cause timing variance:

| Check From: | Check To: | Ohms Reading: | DVA Reading    |
|-------------|-----------|---------------|----------------|
| White/Red   | Black     | 12 to 16      | 5 V @ cranking |

### NO SPARK OR INTERMITTENT ON ONE CYLINDER:

1. Check the resistance of the trigger and ignition coil.
2. Check the flywheel magnets for loose or broken magnets.
3. Replace the ignition coil.

| Check From:         | Check To:    | Ohms Reading: | DVA Reading    |
|---------------------|--------------|---------------|----------------|
| White/Red (Trigger) | Black        | 12 to 16      | 5 V @ cranking |
| Coil Lead #1        | Coil Lead #2 | 2.56K-4.2K    |                |

### ENGINE WILL NOT ACCELERATE ABOVE APPROXIMATELY 2500 RPM:

1. Using an inductive tachometer, check the RPM on both cylinders. A difference in readings between the individual cylinders can be caused by a bad coil or loose/broken magnets.
2. If both cylinders show the same RPM and the engine will only rev to approximately 2500 RPM, check the running stator DVA output from idle thru WOT. You should show a steady increase in voltage on the Blue to engine ground through approximately 2000 RPM, then slowly decreasing the remainder of the RPM range. A sharp drop in voltage can be the result of a bad stator coil or a bad pack.

### WILL NOT STOP (KILL):

Short the White wire from the CD Module to engine ground. If the engine stops, the problem is in the stop circuit. If the engine continues to run with the White wire shorted to engine ground, replace the defective CD Module.

# Yamaha Troubleshooting

## 25 HP (2 CYL) 1988-1993 6L2-85540-10-00

### NO SPARK:

1. Disconnect the White stop wire and retest. If the ignition system now has spark, the stop circuit has a problem.
2. Inspect and clean all engine and ignition ground connections.
3. Check the Resistance and DVA Voltage of the CDI, Stator and Triggers as follows:

| Check From:              | Check To:       | Ohms Reading: | DVA Reading:                      |
|--------------------------|-----------------|---------------|-----------------------------------|
| White/Red                | Black           | 260 to 390    | 5.5 V @ cranking/ 15 V @ 1500 RPM |
| White/Black              | Black           | 260 to 390    | 5.5 V @ cranking/ 15 V @ 1500 RPM |
| Brown (Charge Coil)      | Blue            | 160 to 240    | 100 V @ cranking/310 V @ 1500 RPM |
| Black/Orange (Top Cyl)   | Black (Eng Gnd) | 0.18 to 0.24  | 100 V @ cranking/260 V @ 1500 RPM |
| Black/White (Bottom Cyl) | Black (Eng Gnd) | 0.18 to 0.24  | 100 V @ cranking/260 V @ 1500 RPM |

### HAS SPARK BUT WILL NOT RUN:

1. Make sure the engine is getting fuel to the combustion chamber (make sure there is no water or residue in the carburetor).
2. Check flywheel shear key and magnets to make sure it has not broken loose and moved, causing a timing shift.
3. Check spark plug for presence of water, indicating a possible cracked block or blown head gasket.
4. Check compression, carburetor, reeds and do a cylinder leak down test (12% leakdown max).

### NO SPARK OR INTERMITTENT ON ONE CYLINDER:

1. Check the resistance of the trigger and ignition coil.

| Check From:              | Check To:       | Ohms Reading: | DVA Reading:                      |
|--------------------------|-----------------|---------------|-----------------------------------|
| White/Red                | Black           | 260 to 390    | 5.5 V @ cranking/ 15 V @ 1500 RPM |
| White/Black              | Black           | 260 to 390    | 5.5 V @ cranking/ 15 V @ 1500 RPM |
| Brown (Charge Coil)      | Blue            | 160 to 240    | 100 V @ cranking/310 V @ 1500 RPM |
| Black/Orange (Top Cyl)   | Black (Eng Gnd) | 0.18 to 0.24  | 100 V @ cranking/260 V @ 1500 RPM |
| Black/White (Bottom Cyl) | Black (Eng Gnd) | 0.18 to 0.24  | 100 V @ cranking/260 V @ 1500 RPM |
| Coil Lead #1             | Black           | 2.02K-2.18K   |                                   |
| Coil Lead #2             | Black           | 2.02K-2.18K   |                                   |

2. Check the flywheel magnets for loose or broken magnets.

### WILL NOT STOP (KILL):

Short the White wire from the CD Module to engine ground. If the engine stops, the problem is in the stop circuit. If the engine continues to run with the White wire shorted to engine ground, replace the defective CD Module.

### WILL NOT ACCELERATE OVER 2000 RPM:

1. Disconnect the Pink wire from the CDI and retest. If the engine now runs normally, check the head temperature sensor and the oil tank sensor.
2. Disconnect the White wire from the CD Module and retest. If the engine runs normally, the harness could have a intermittent short.

**C25 HP (2 CYL) 1990-1997**  
**695-85540-11-00**

**NO SPARK:**

1. Disconnect the White stop wire and retest. If the ignition system now has spark, the stop circuit has a problem.
2. Inspect and clean all engine and ignition ground connections.
3. Check the resistance of the ignition coil.

| Check From:      | Check To:        | Ohms Reading:                             |
|------------------|------------------|---|
| Spark Plug Cap 1 | Spark Plug Cap 2 | 2.72K (2720) to 3.68K (3680) (1990-1992)  |
| Spark Plug Cap 1 | Spark Plug Cap 2 | 4.52K (4520) to 6.28K (6280) (1993-1995)  |
| Spark Plug Cap 1 | Spark Plug Cap 2 | 6.8K (6800) to 10.2K (10,200) (1996-1997) |

4. Check the Resistance and DVA Voltage of the CDI, Stator and Triggers as follows:

| Check From:         | Check To:       | Ohms Reading: | DVA Reading      |
|---------------------|-----------------|---------------|------------------|
| White/Red           | Black           | 90 to 112     | 5 V @ cranking   |
| Brown (Charge Coil) | Black           | 188 to 282    | 190 V @ cranking |
| Black/Orange        | Black (Eng Gnd) | 0.18 to 0.24  | 210 V @ cranking |

**HAS SPARK BUT WILL NOT RUN:**

1. Make sure the engine is getting fuel to the combustion chamber (make sure there is no water or residue in the carburetor).
2. Check flywheel shear key to make sure it has not sheared due to backfiring or impact on the propeller.
3. Check flywheel magnet to make sure it has broken loose and moved, causing a timing shift.
4. Check spark plug for presence of water, indicating a possible cracked block or blown head gasket.
5. Check compression, carburetor, reeds and do a cylinder leak down test.
6. Check the Triggers as follows as a defective trigger can cause timing variance:

| Check From: | Check To: | Ohms Reading: | DVA Reading:   |
|-------------|-----------|---------------|----------------|
| White/Red   | Black     | 90 to 112     | 5 V @ cranking |

**NO SPARK ON ONE CYLINDER:**

If only one cylinder has spark, replace the ignition coil.

**WILL NOT STOP (KILL):**

Short the White wire from the CD Module to engine ground. If the engine stops, the problem is in the stop circuit. If the engine continues to run with the White wire shorted to engine ground, replace the defective CD Module.

**25/30 HP (3 CYL) 1996-2002**  
**6J8-85540-H1-00**

**NO SPARK ON ANY CYLINDER:**

1. Disconnect the White stop wire and retest. If the engine's ignition now has spark, the stop circuit has a fault-check the key switch, harness and shift switch.
2. Inspect and clean all engine and ignition ground connections.
3. Verify the correct spark plugs are installed.
4. Check the resistance and DVA output of the Stator and Trigger:

| Read from                | Read to          | Ohms Reading | DVA (connected) | DVA (Disconnected) |
|--------------------------|------------------|--------------|-----------------|--------------------|
| White/Red Trigger wire   | Black wire       | 277-415      | 4 V Minimum     | 4 V Minimum        |
| White/Black Trigger wire | Black wire       | 277-415      | 4 V Minimum     | 4 V Minimum        |
| White/Green Trigger wire | Black wire       | 277-415      | 4 V Minimum     | 4 V Minimum        |
| Brown Stator wire        | Blue Stator wire | 164-246      | 175 V Minimum   | 210 V Minimum      |

## **Yamaha Troubleshooting**

### **NO SPARK OR INTERMITTENT ON ONE OR MORE CYLINDERS:**

1. Check the resistance and DVA output of the Trigger:

| Read from                | Read to    | Ohms Reading | DVA (connected) | DVA (Disconnected) |
|--------------------------|------------|--------------|-----------------|--------------------|
| White/Red Trigger wire   | Black wire | 277-415      | 4 V Minimum     | 4 V Minimum        |
| White/Black Trigger wire | Black wire | 277-415      | 4 V Minimum     | 4 V Minimum        |
| White/Green Trigger wire | Black wire | 277-415      | 4 V Minimum     | 4 V Minimum        |
| Black/White Coil wire    | Black wire | 5.04K-7.56K  |                 |                    |

2. Check the DVA output on the Black/Orange, Black/White and Black/Yellow wires from the power pack while connected to the ignition coils. You should have a reading of at least 135V or more. If the reading is low on one cylinder, disconnect the wire from the ignition coil for that cylinder and reconnect it to a load resistor. Retest. If the reading is now good, the ignition coil is likely bad. A continued low reading indicates a bad power pack or trigger (test per above).

### **ENGINE WILL NOT ACCELERATE ABOVE APPROXIMATELY 2000 RPM:**

1. Verify the engine is not overheating and causing the power pack to limit the RPM.
2. Disconnect the Pink wire from the power pack and retest. If the engine now performs correctly, check the overheat sensor, oil level in the oil tank mounted on the engine and the wiring harness.
3. Check the position of the Pink wire and make sure it is not next to a spark plug wire.

### **ENGINE WILL NOT ACCELERATE ABOVE APPROXIMATELY 2500 RPM:**

1. Using an inductive tachometer, check the RPM on all cylinders. A difference in readings between the individual cylinders can be caused by a bad coil, power pack or spark plug.
2. If all cylinders show the same RPM and the engine will only rev to approximately 2500 RPM, check the running stator DVA output from idle thru WOT. You should show a steady increase in voltage on the Blue to the Brown stator wires throughout the RPM range. A drop in voltage can be the result of a bad stator coil or a bad pack.

### **HIGH SPEED MISS:**

1. Verify the engine is not overheating and causing the problem.
2. Using an inductive tachometer, check the RPM on all cylinders. A difference in readings between the individual cylinders can be caused by a bad coil, power pack or spark plug.

### **S.A.F.E. WILL NOT ENGAGE:**

Disconnect the Pink warning wire from the power pack. Connect a jumper wire to engine ground and connect it to the Pink wire from the power pack (If it still fails to engage, the power pack is likely bad). If the engine now limits at approximately 2000 RPM, check the wiring from the temperature sensor and oil tank to the power pack.

### **ENGINE WILL NOT KILL (STOP)**

Using a jumper wire, connect the White kill wire from the pack to engine ground. If you still have spark, the power pack is likely bad. If the engine has no spark with the jumper connected, either the wiring harness, keyswitch or emergency stop switch is bad.

### **WARNING LED WILL NOT WORK:**

1. Disconnect the Pink wire from the temperature sensor and short it to ground. Start and run the engine, the warning LED and the horn should sound (if equipped with a horn).
2. Disconnect the Pink wire from the LED and short the Pink wire from the LED to engine ground. Start and run the engine, if the LED now works, check the wiring from the temperature sensor to the LED connection.
3. Disconnect the Pink wire from the LED and short the Pink wire from the LED to engine ground. Connect a DC voltmeter to the Yellow/Red wire coming from the CD module and check the voltage. You should have 0.5 – 1.5 volts.

## Yamaha Troubleshooting

### C30 HP (2 CYL) 1993-1997 61N-85540-00-00

#### NO SPARK ON ANY CYLINDER:

1. Disconnect the White stop wire and retest. If the ignition system now has spark, the stop circuit has a problem.
2. Inspect and clean all engine and ignition ground connections.
3. Check the resistance of the ignition coil.

| Check From:      | Check To:        | Ohms Reading:                            |
|------------------|------------------|--|
| Spark Plug Cap 1 | Spark Plug Cap 2 | 2.72K (2720) to 3.68K (3680) (1990-1992) |

4. Check the Resistance and DVA Voltage of the CDI, Stator and Triggers as follows:

| Check From:         | Check To:       | Ohms Reading:        | DVA Reading:     |
|---------------------|-----------------|----------------------|------------------|
| White/Red           | Black           | 304 to 430           | 4 V @ cranking   |
| White/Black         | Black           | 304 to 430           | 4 V @ cranking   |
| Brown (Charge Coil) | Blue            | 356 to 580 (1993-96) | 125 V @ cranking |
| Brown (Charge Coil) | Blue            | 304 to 475 (1997)    | 125 V @ cranking |
| Black/Orange        | Black (Eng Gnd) | 0.18 to 0.24         | 100 V @ cranking |

#### HAS SPARK BUT WILL NOT RUN:

1. Make sure the engine is getting fuel to the combustion chamber (make sure there is no water or residue in the carburetor).
2. Check flywheel shear key to make sure it has not sheared due to backfiring or impact on the propeller.
3. Check flywheel magnet to make sure it has not broken loose and moved, causing a timing shift.
4. Check spark plug for presence of water, indicating a possible cracked block or blown head gasket.
5. Check compression, carburetor, reeds and do a cylinder leak down test.
6. Check the Triggers as follows as a defective trigger can cause timing variance:

| Check From: | Check To: | Ohms Reading: | DVA Reading:   |
|-------------|-----------|---------------|----------------|
| White/Red   | Black     | 304 to 430    | 4 V @ cranking |
| White/Black | Black     | 304 to 430    | 4 V @ cranking |

#### NO SPARK ON ONE CYLINDER:

1. Swap the ignition coil from the cylinder not firing to the cylinder that is firing. If the no fire problem follows the ignition coil, replace the coil.
2. Check the Resistance Ignition Coil as follows:

| Check From: | Check To: | Ohms Reading: | DVA Reading:   |
|-------------|-----------|---------------|----------------|
| White/Red   | Black     | 304 to 430    | 4 V @ cranking |
| White/Black | Black     | 304 to 430    | 4 V @ cranking |

#### WILL NOT STOP (KILL):

1. Disconnect the White wire from the CD Module.
2. Short the White wire from the CD Module to engine ground. If the engine stops, the problem is in the stop circuit. If the engine continues to run with the White wire shorted to engine ground, replace the defective CD Module.

### 30 HP (3 CYL) 1987-2002

#### 6J8-85540-H1-00/6J8-85540-H2-00/117-6J8-H1/117-6J8-H2

#### NO SPARK ON ANY CYLINDER:

1. Disconnect the White stop wire and retest. If the engine's ignition now has spark, the stop circuit has a fault-check the key switch, harness and shift switch.
2. Verify the correct spark plugs are installed.
3. Inspect and clean all engine and ignition ground connections.
4. Check the resistance and DVA output of the Stator and Trigger:

| Read from                | Read to          | Ohms Reading | DVA (connected) | DVA (Disconnected) |
|--------------------------|------------------|--------------|-----------------|--------------------|
| White/Red Trigger wire   | Black wire       | 277-415      | 4 V Minimum     | 4 V Minimum        |
| White/Black Trigger wire | Black wire       | 277-415      | 4 V Minimum     | 4 V Minimum        |
| White/Green Trigger wire | Black wire       | 277-415      | 4 V Minimum     | 4 V Minimum        |
| Brown Stator wire        | Blue Stator wire | 164-246      | 175 V Min       | 210 V Minimum      |



## **Yamaha Troubleshooting**

### **NO SPARK OR INTERMITTENT ON ONE OR MORE CYLINDERS:**

1. Check the resistance and DVA output of the Trigger:

| Read from                | Read to    | OEM Reading | DVA (connected) | DVA (Disconnected) |
|--------------------------|------------|-------------|-----------------|--------------------|
| White/Red Trigger wire   | Black wire | 277-415     | 4 V Minimum     | 4 V Minimum        |
| White/Black Trigger wire | Black wire | 277-415     | 4 V Minimum     | 4 V Minimum        |
| White/Green Trigger wire | Black wire | 277-415     | 4 V Minimum     | 4 V Minimum        |

2. Check the DVA output on the Black/Orange, Black/White and Black/Yellow wires from the power pack while connected to the ignition coils. You should have a reading of at least 135V or more. If the reading is low on one cylinder, disconnect the wire from the ignition coil for that cylinder and reconnect it to a load resistor. Retest. If the reading is now good, the ignition coil is likely bad. A continued low reading indicates a bad power pack or trigger (test per above).
3. Swap the ignition coil that is not firing with one that is firing. If the problem stays with the same coil, replace the coil.

### **ENGINE WILL NOT ACCELERATE ABOVE APPROXIMATELY 2000 RPM:**

1. Verify the engine is not overheating and causing the power pack to limit the RPM.
2. Disconnect the Pink wire from the power pack and retest. If the engine now performs correctly, check the overheat sensor, oil level in the oil tank mounted on the engine and the wiring harness.
3. Check the position of the Pink wire and make sure it is not next to a spark plug wire.

### **ENGINE WILL NOT ACCELERATE ABOVE APPROXIMATELY 2500 RPM:**

1. Using an inductive tachometer, check the RPM on all cylinders. A difference in readings between the individual cylinders can be caused by a bad coil, power pack or spark plug.
2. If all cylinders show the same RPM and the engine will only rev to approximately 2500 RPM, check the running stator DVA output from idle thru WOT. You should show an increase in voltage on the Blue to the Brown stator wires from idle through approximately 2000 RPM and remaining steady, dropping slightly over 4000 RPM range. A sharp drop in voltage can be the result of a bad stator coil or a bad pack.

### **HIGH SPEED MISS:**

1. Verify the engine is not overheating and causing the problem.
2. Using an inductive tachometer, check the RPM on all cylinders. A difference in readings between the individual cylinders can be caused by a bad coil, power pack or spark plug.

### **S.A.F.E. WILL NOT ENGAGE:**

Disconnect the Pink warning wire from the power pack. Connect a jumper wire to engine ground and connect it to the Pink wire from the power pack (If it still fails to engage, the power pack is likely bad). If the engine now limits at approximately 2000 RPM, check the wiring from the temperature sensor and oil tank to the power pack.

### **ENGINE WILL NOT KILL (STOP)**

Connect a jumper wire to the White wire from the power pack to engine ground. If you still have spark, the power pack is likely bad. If the engine has no spark with the jumper connected, either the wiring harness, keyswitch or emergency stop switch is bad.

### **WARNING LED WILL NOT WORK:**

1. Disconnect the Pink wire from the temperature sensor and short it to ground. Start and run the engine, the warning LED and the horn should sound (if equipped with a horn).
2. Disconnect the Pink wire from the LED and short the Pink wire from the LED to engine ground. Start and run the engine, if the LED now works, check the wiring from the temperature sensor to the LED connection.
3. Disconnect the Pink wire from the LED and short the Pink wire from the LED to engine ground. Connect a DC voltmeter to the Yellow/Red wire coming from the CD module and check the voltage. You should have 0.5 – 1.5 volts.

## Yamaha Troubleshooting

### C40/CV40 HP (2 Cyl) 1990-1997

689-85540-21-00/117-689-21

#### NO SPARK:

1. Disconnect the White stop wire and retest. If the ignition system now has spark, the stop circuit has a problem.
2. Inspect and clean all engine and ignition ground connections.
3. Check the resistance of the ignition coil.

| Check From:      | Check To:        | Ohms Reading:              |
|------------------|------------------|----------------------------|
| Spark Plug Cap 1 | Spark Plug Cap 2 | 2.8K (2800) to 4.2K (4200) |

4. Check the Resistance and DVA Voltage of the CDI, Stator and Triggers as follows:

| Check From:         | Check To:       | Ohms Reading: | DVA Reading:    |
|---------------------|-----------------|---------------|-----------------|
| White/Red           | Black           | 12 to 16      | 5 V @ cranking  |
| Brown (Charge Coil) | Black           | 120 to 148    | 190V @ cranking |
| Black/White         | Black (Eng Gnd) | 0.18 to 0.24  | 210V @ cranking |

#### HAS SPARK BUT WILL NOT RUN:

1. Make sure the engine is getting fuel to the combustion chamber (make sure there is no water or residue in the carburetor).
2. Check flywheel shear key to make sure it has not sheared due to backfiring or impact on the propeller.
3. Check flywheel magnet to make sure it has not broken loose and moved, causing a timing shift.
4. Check spark plug for presence of water, indicating a possible cracked block or blown head gasket.
5. Check compression, carburetor, reeds and do a cylinder leak down test.
6. Check the Triggers as follows as a defective trigger can cause timing variance:

| Check From: | Check To: | Ohms Reading: | DVA Reading    |
|-------------|-----------|---------------|----------------|
| White/Red   | Black     | 12 to 16      | 5 V @ cranking |

#### NO SPARK OR INTERMITTENT ON ONE CYLINDER:

1. Check the resistance of the trigger and ignition coil.

| Check From:         | Check To:        | Ohms Reading:              | DVA Reading    |
|---------------------|------------------|----------------------------|----------------|
| White/Red (Trigger) | Black            | 12 to 16                   | 5 V @ cranking |
| Spark Plug Cap 1    | Spark Plug Cap 2 | 2.8K (2800) to 4.2K (4200) |                |

2. Check the flywheel magnets for loose or broken magnets.
3. Replace the ignition coil.

#### ENGINE WILL NOT STOP (KILL):

Short the White wire from the CD Module to engine ground. If the engine stops, the problem is in the stop circuit. If the engine continues to run with the White wire shorted to engine ground, replace the defective CD Module.

### 40 HP (3 CYL) 1984-1988

6H4-85540-21-00/117-6H4-21

#### NO SPARK ON ANY CYLINDER:

1. Disconnect the White stop wire and retest. If the engine's ignition now has spark, the stop circuit has a fault-check the key switch, harness and shift switch.
2. Inspect and clean all engine and ignition ground connections.
3. Verify the correct spark plugs are installed.
4. Check the resistance and DVA output of the Stator and Trigger:

| Read from                | Read to          | Ohm Reading | DVA (connected to pack) | DVA (Disconnected) |
|--------------------------|------------------|-------------|-------------------------|--------------------|
| White/Red Trigger wire   | Black wire       | 277-415     | 3 V Minimum             | 4 V Minimum        |
| White/Black Trigger wire | Black wire       | 277-415     | 3 V Minimum             | 4 V Minimum        |
| White/Green Trigger wire | Black wire       | 277-415     | 3 V Minimum             | 4 V Minimum        |
| Brown Stator wire        | Blue Stator wire | 164-246     | 150 V Minimum           | 175 V Minimum      |

5. Check the cranking RPM. A cranking speed of less than 250-RPM will not allow the system to fire properly.

## **Yamaha Troubleshooting**

### **NO SPARK OR INTERMITTENT ON ONE OR MORE CYLINDERS:**

1. Check the resistance and DVA output of the Trigger:

| Read from                | Read to    | Ohm Reading | DVA (connected to pack) | DVA (Disconnected) |
|--------------------------|------------|-------------|-------------------------|--------------------|
| White/Red Trigger wire   | Black wire | 277-415     | 3 V Minimum             | 4 V Minimum        |
| White/Black Trigger wire | Black wire | 277-415     | 3 V Minimum             | 4 V Minimum        |
| White/Green Trigger wire | Black wire | 277-415     | 3 V Minimum             | 4 V Minimum        |

2. Check the DVA output on the Black/Orange, Black/White and Black/Yellow wires from the power pack while connected to the ignition coils. You should have a reading of at least 135V or more. If the reading is low on one cylinder, disconnect the wire from the ignition coil for that cylinder and reconnect it to a load resistor. Retest. If the reading is now good, the ignition coil is likely bad. A continued low reading indicates a bad power pack or trigger (test per above).

### **ENGINE WILL NOT ACCELERATE ABOVE APPROXIMATELY 2000 RPM:**

1. Verify the engine is not overheating and causing the power pack to limit the RPM.
2. Disconnect the Pink wire from the power pack and retest. If the engine now performs correctly, check the overheat sensor, oil level in the oil tank mounted on the engine and the wiring harness.
3. Check the position of the Pink wire and make sure it is not next to a spark plug wire.

### **ENGINE WILL NOT ACCELERATE ABOVE APPROXIMATELY 2500 RPM:**

1. Using an inductive tachometer, check the RPM on all cylinders. A difference in readings between the individual cylinders can be caused by a bad coil, power pack or spark plug.
2. If all cylinders show the same RPM and the engine will only rev to approximately 2500 RPM, check the running stator DVA output from idle thru WOT. You should show an increase in voltage on the Blue to the Brown stator wires from idle to approximately 2000 RPM and remaining steady, dropping slightly over 4000 RPM range. A sharp drop in voltage can be the result of a bad stator coil or a bad pack.

### **HIGH SPEED MISS:**

1. Verify the engine is not overheating and causing the problem.
2. Using an inductive tachometer, check the RPM on all cylinders. A difference in readings between the individual cylinders can be caused by a bad coil, power pack or spark plug.

### **S.A.F.E. WILL NOT ENGAGE:**

Disconnect the Pink warning wire from the power pack. Connect a jumper wire to engine ground and connect it to the Pink wire from the power pack (If it still fails to engage, the power pack is likely bad). If the engine now limits at approximately 2000 RPM, check the wiring from the temperature sensor and oil tank to the power pack.

### **ENGINE WILL NOT KILL (STOP)**

Short the White wire from the CD Module to engine ground. If the engine stops, the problem is in the stop circuit. If the engine continues to run with the White wire shorted to engine ground, replace the defective CD Module.

### **WARNING LED WILL NOT WORK:**

1. Disconnect the Pink wire from the temperature sensor and short it to ground. Start and run the engine, the warning LED and the horn should sound (if equipped with a horn).
2. Disconnect the Pink wire from the LED and short the Pink wire from the LED to engine ground. Start and run the engine, if the LED now works, check the wiring from the temperature sensor to the LED connection.
3. Disconnect the Pink wire from the LED and short the Pink wire from the LED to engine ground. Connect a DC voltmeter to the Yellow/Red wire coming from the CD module and check the voltage. You should have 0.5 – 1.5 volts.

## Yamaha Troubleshooting

### 40-50 HP (3 CYL) 1989-1994 6H5-85540-02-00/117-6H5-02

#### NO SPARK ON ANY CYLINDER:

1. Disconnect the White stop wire and retest. If the engine's ignition now has spark, the stop circuit has a fault-check the key switch, harness and shift switch.
2. Inspect and clean all engine and ignition ground connections.
3. Verify the correct spark plugs are installed.
4. Check the resistance and DVA output of the Stator and Trigger:

| Read from                | Read to          | Ohm Reading | DVA (connected) | DVA           |
|--------------------------|------------------|-------------|-----------------|---------------|
| <u>(Disconnected)</u>    |                  |             |                 |               |
| White/Red Trigger wire   | Black wire       | 157-235     | 3 V Minimum     | 4 V Minimum   |
| White/Black Trigger wire | Black wire       | 157-235     | 3 V Minimum     | 4 V Minimum   |
| White/Green Trigger wire | Black wire       | 157-235     | 3 V Minimum     | 4 V Minimum   |
| Brown Stator wire        | Blue Stator wire | 238-356     | 200 V Minimum   | 190 V Minimum |

5. Check the cranking RPM. A cranking speed of less than 250-RPM may not allow the system to fire properly.

#### NO SPARK OR INTERMITTENT ON ONE OR MORE CYLINDERS:

1. Check the resistance and DVA output of the Trigger:

| Read from                | Read to       | Ohm Reading | DVA (connected) | DVA (Disconnected) |
|--------------------------|---------------|-------------|-----------------|--------------------|
| White/Red Trigger wire   | Black wire    | 157-235     | 3 V Minimum     | 4 V Minimum        |
| White/Black Trigger wire | Black wire    | 157-235     | 3 V Minimum     | 4 V Minimum        |
| White/Green Trigger wire | Black wire    | 157-235     | 3 V Minimum     | 4 V Minimum        |
| Black/ White (#1)        | Engine Ground | -           | 125 V Minimum   |                    |
| Black/White (#2)         | Engine Ground | -           | 125 V Minimum   |                    |
| Black/ White (#3)        | Engine Ground | -           | 125 V Minimum   |                    |

2. Swap the ignition coil for the problem cylinder with one that is firing correctly. Retest. If the problem stays with the coil, replace it.

#### ENGINE WILL NOT ACCELERATE ABOVE APPROXIMATELY 2000 RPM:

1. Verify the engine is not overheating and causing the power pack to limit the RPM.
2. Disconnect the Pink wire from the power pack and retest. If the engine now performs correctly, check the overheat sensor, oil level in the oil tank mounted on the engine and the wiring harness.
3. Check the position of the Pink wire and make sure it is not next to a spark plug wire.
4. Verify the ignition timing is advancing to the WOT setting (24-26 Degrees BTDC).

#### ENGINE WILL NOT ACCELERATE ABOVE APPROXIMATELY 2500 RPM:

1. Using an inductive tachometer, check the RPM on all cylinders. A difference in readings between the individual cylinders can be caused by a bad coil, power pack or spark plug.
2. If all cylinders show the same RPM and the engine will only rev to approximately 2500 RPM, check the running stator DVA output from idle thru WOT. You should show a steady increase in voltage on the Blue to the Brown stator wires throughout the RPM range. A drop in voltage can be the result of a bad stator coil or a bad pack.

#### HIGH SPEED MISS:

1. Verify the engine is not overheating and causing the problem.
2. Using an inductive tachometer, check the RPM on all cylinders. A difference in readings between the individual cylinders can be caused by a bad coil, power pack or spark plug.

#### S.A.F.E. WILL NOT ENGAGE:

Disconnect the Pink warning wire from the power pack. Connect a jumper wire to engine ground and connect it to the Pink wire from the power pack (If it still fails to engage, the power pack is likely bad). If the engine now limits at approximately 2000 RPM, check the wiring from the temperature sensor and oil tank to the power pack.

## **Yamaha Troubleshooting**

### **ENGINE WILL NOT STOP RUNNING:**

Short the White wire from the CD Module to engine ground. If the engine stops, the problem is in the stop circuit. If the engine continues to run with the White wire shorted to engine ground, replace the defective CD Module.

### **WARNING LED WILL NOT WORK:**

1. Disconnect the Pink wire from the temperature sensor and short it to ground. Start and run the engine, the warning LED and the horn should sound (if equipped with a horn).
2. Disconnect the Pink wire from the LED and short the Pink wire from the LED to engine ground. Start and run the engine, if the LED now works, check the wiring from the temperature sensor to the LED connection.

**40/50 HP (3 CYL) 1995-2009  
C40/CV40 (3 Cyl) 1997-2003  
63D-85540-04-00/117-63D-04**

### **NO SPARK ON ANY CYLINDER:**

1. Disconnect the White stop wire and retest. If the engine's ignition now has spark, the stop circuit has a fault-check the key switch, harness and shift switch.
2. Inspect and clean all engine and ignition ground connections.
3. Verify the correct spark plugs are installed.
4. Check the resistance and DVA output of the Stator and Trigger:

| Read from                | Read to          | Ohm Reading | DVA (connected) | DVA (Disconnected) |
|--------------------------|------------------|-------------|-----------------|--------------------|
| White/Red Trigger wire   | Black wire       | 168-252     | 3 V Minimum     | 4 V Minimum        |
| White/Black Trigger wire | Black wire       | 168-252     | 3 V Minimum     | 4 V Minimum        |
| White/Green Trigger wire | Black wire       | 168-252     | 3 V Minimum     | 4 V Minimum        |
| Brown Stator wire        | Blue Stator wire | 368-552     | 145 V Minimum   | 125 V Minimum      |
| Black/Orange             | Engine Ground    |             | -               | 125 V Minimum      |
| Black/White              | Engine Ground    |             | -               | 125 V Minimum      |
| Black/Yellow             | Engine Ground    |             | -               | 125 V Minimum      |

5. Check the cranking RPM. A cranking speed of less than 250-RPM may not allow the system to fire properly.

### **NO SPARK OR INTERMITTENT ON ONE OR MORE CYLINDERS:**

1. Check the resistance and DVA output of the Trigger:

| Read from                | Read to       | Ohm Reading | DVA (connected) | DVA (Disconnected) |
|--------------------------|---------------|-------------|-----------------|--------------------|
| White/Red Trigger wire   | Black wire    | 168-252     | 3 V Minimum     | 4 V Minimum        |
| White/Black Trigger wire | Black wire    | 168-252     | 3 V Minimum     | 4 V Minimum        |
| White/Green Trigger wire | Black wire    | 168-252     | 3 V Minimum     | 4 V Minimum        |
| Black/Orange             | Engine Ground | 2.8K-4.2K   | 125 V Minimum   |                    |
| Black/White              | Engine Ground | 2.8K-4.2K   | 125 V Minimum   |                    |
| Black/Yellow             | Engine Ground | 2.8K-4.2K   | 125 V Minimum   |                    |

2. If the reading is low on one cylinder, disconnect the wire from the ignition coil for that cylinder and reconnect it to a load resistor. Retest. If the reading is now good, the ignition coil is likely bad. A continued low reading indicates a bad power pack or trigger (test per above).

### **ENGINE WILL NOT ACCELERATE ABOVE APPROXIMATELY 2000 RPM:**

1. Verify the engine is not overheating and causing the power pack to limit the RPM.
2. Disconnect the Pink wire from the power pack and retest. If the engine now performs correctly, check the overheat sensor, oil level in the oil tank mounted on the engine and the wiring harness.
3. Check the position of the Pink wire and make sure it is not next to a spark plug wire.
4. Verify the ignition timing is advancing to the WOT setting (24-28 Degrees BTDC).

### **ENGINE WILL NOT ACCELERATE ABOVE APPROXIMATELY 2500 RPM:**

1. Using an inductive tachometer, check the RPM on all cylinders. A difference in readings between the individual cylinders can be caused by a bad coil, power pack or spark plug.
2. If all cylinders show the same RPM and the engine will only rev to approximately 2500 RPM, check the running stator DVA output from idle thru WOT. You should show a steady increase in voltage on the Blue to the Brown stator wires throughout the RPM range. A drop in voltage can be the result of a bad stator coil or a bad pack.



## Yamaha Troubleshooting

### HIGH SPEED MISS:

1. Verify the engine is not overheating and causing the problem.
2. Using an inductive tachometer, check the RPM on all cylinders. A difference in readings between the individual cylinders can be caused by a bad coil, power pack or spark plug.

### S.A.F.E. WILL NOT ENGAGE:

Disconnect the Pink warning wire from the power pack. Connect a jumper wire to engine ground and connect it to the Pink wire from the power pack (If it still fails to engage, the power pack is likely bad). If the engine now limits at approximately 2000 RPM, check the wiring from the temperature sensor and oil tank to the power pack.

### ENGINE WILL NOT STOP RUNNING:

Connect a jumper wire to the White wire from the ignition pack to engine ground. If you still have spark, the power pack is likely bad. If the engine has no spark with the jumper connected, either the wiring harness, keyswitch or emergency stop switch is bad.

### E48 HP (2 Cyl) 1995-2000 696-85540-00-00

#### NO SPARK ON ANY CYLINDER:

1. Disconnect the White stop wire and retest. If the ignition system now has spark, the stop circuit has a problem.
2. Inspect and clean all engine and ignition ground connections.
3. Check the resistance and DVA voltage of the charge coil, trigger coil and ignition coil.

| Check From:              | Check To:       | Ohms Reading:                  | DVA Connected |
|--------------------------|-----------------|--------------------------------|---------------|
| White/Red                | Black           | 82 to 122                      | 4 V Minimum   |
| Brown (Charge Coil)      | Black           | 81 to 99                       | 110 V Minimum |
| Black/Orange (Top Cyl)   | Black (Eng Gnd) | N/A                            | 170 V Minimum |
| Black/White (Bottom Cyl) | Black (Eng Gnd) | N/A                            | 170 V Minimum |
| Spark Plug Cap 1         | Spark Plug Cap  | 2.4.62K (4620) to 6.28K (6280) |               |

#### NO SPARK ON ONE CYLINDER:

If only one cylinder has spark, replace the ignition coil.

#### HAS SPARK BUT WILL NOT RUN:

1. Make sure the engine is getting fuel to the combustion chamber (make sure there is no water or residue in the carburetor).
2. Check flywheel shear key to make sure it has not sheared due to backfiring or impact on the propeller.
3. Check flywheel magnet to make sure it has not broken loose and moved, causing a timing shift.
4. Check spark plug for presence of water, indicating a possible cracked block or blown head gasket.
5. Check compression, carburetor, reeds and do a cylinder leak down test.
6. Check the fuel in the carburetor. Check to see if a very high ethanol content is present. . If so, purge the fuel system with fresh fuel and see if the engine will start.
7. Check the fuel pressure AT THE CARBURETOR. You should see over 2 PSI. Check fuel lines for inner wall breakdown and wall collapse.
8. Check the Triggers as follows as a defective trigger can cause timing variance:

| Check From: | Check To: | Ohms Reading: | DVA Reading: |
|-------------|-----------|---------------|--------------|
| White/Red   | Black     | 82 to 122     | 4 V Minimum  |

#### WILL NOT STOP (KILL):

1. Disconnect the White wire from the CD Module.
2. Short the White wire from the CD Module to engine ground. If the engine stops, the problem is in the stop circuit. If the engine continues to run with the White wire shorted to engine ground, replace the defective CD Module.

### C55 HP (2 Cyl) 1989-1994

663-85540-15-00/663-85540-01-00/83030M/117-TIA02-12

#### NO SPARK ON ANY CYLINDER:

1. Disconnect the White stop wire and retest. If the engine's ignition has spark, the stop circuit has a fault-check the key switch, harness and shift switch.

## **Yamaha Troubleshooting**

- Inspect and clean all engine and ignition ground connections.
- Disconnect the yellow wire from the pack and retest. If the engine now sparks, the Blanker coil is likely bad.

- Check the stator resistance.

| Read from | Read to | Reading | Ohms  | DVA (connected to pack) |
|-----------|---------|---------|-------|-------------------------|
| Brown     | Blue    | 188-282 | 135 V | Minimum                 |

- Check the resistance and DVA output of the Triggers:

| Read from                | Read to       | Reading | Ohms | DVA (connected to pack) |
|--------------------------|---------------|---------|------|-------------------------|
| White/Red Trigger wire   | Engine ground | 63-93   | 2 V  | Minimum                 |
| White/Black Trigger wire | Engine ground | 63-93   | 2 V  | Minimum                 |
| Yellow                   | Engine ground | 22-30   | 10 V | Minimum                 |

- Check the cranking RPM. A cranking speed of less than 250-RPM will not allow the system to fire properly.

### **NO SPARK OR INTERMITTENT ON ONE OR MORE CYLINDERS:**

- Check the resistance and DVA output of the stator plate assembly:

| Read from                | Read to       | Reading | Ohms | DVA (connected to pack) |
|--------------------------|---------------|---------|------|-------------------------|
| White/Red Trigger wire   | Engine ground | 65-93   | 2 V  | Minimum                 |
| White/Black Trigger wire | Engine ground | 65-85   | 2 V  | Minimum                 |

- Check the Blanker coil as follows as a defective Blanker coil can cause timing variance or not fire:

| Check From: | Check To:     | Ohms Reading: | DVA Reading: |
|-------------|---------------|---------------|--------------|
| Yellow      | Engine ground | 25-35 ohms    | 10 V Minimum |

- Check the DVA output on the Black/White wires from the power pack while connected to the ignition coils.

| Read from        | Read to       | DVA (connected to pack) |
|------------------|---------------|-------------------------|
| Black/White Coil | Engine ground | 150 V (1989-94) Minimum |

- If the reading is low on one cylinder, disconnect the wire from the ignition coil for that cylinder and reconnect it to a load resistor. Retest. If the reading is now good, the ignition coil is likely bad. A continued low reading indicates a bad power pack or trigger (test per above).

### **HAS SPARK BUT WILL NOT RUN:**

- Make sure the engine is getting fuel to the combustion chamber (make sure there is no water or residue in the carburetor). Also, check to see if a very high ethanol content is present. If so, purge the fuel system with fresh fuel and see if the engine will start.
- Check flywheel shear key to make sure it has not sheared due to backfiring or impact on the propeller.
- Check flywheel magnet to make sure it has not broken loose and moved, causing a timing shift.
- Check spark plug for presence of water, indicating a possible cracked block or blown head gasket.
- Check compression, carburetor, reeds and do a cylinder leak down test.
- Check the fuel pressure AT THE CARBURETOR. You should see over 2 PSI. Check fuel lines for inner wall breakdown and wall collapse.
- Check the Blanker coil as follows as a defective Blanker coil can cause timing variance or not fire:

| Check From: | Check To:     | Ohms Reading: | DVA Reading:     |
|-------------|---------------|---------------|------------------|
| Yellow      | Engine ground | 25-35 ohms    | 10 Volts Minimum |

### **WILL NOT STOP (KILL):**

Short the White wire from the CD Module to engine ground. If the engine stops, the problem is in the stop circuit. If the engine continues to run with the White wire shorted to engine ground, replace the defective CD Module.

## **C55 HP (2 Cyl) 1995 697-85540-00-00**

### **NO SPARK ON ANY CYLINDER:**

- Disconnect the White stop wire and retest. If the engine's ignition has spark, the stop circuit has a fault-check the key switch, harness and shift switch.
- Inspect and clean all engine and ignition ground connections.
- Disconnect the yellow wire from the pack and retest. If the engine now sparks, the Blanker coil is likely bad.

## Yamaha Troubleshooting

4. Check the stator resistance.

| Read from | Read to | Reading | Ohms | DVA (connected to pack) |
|-----------|---------|---------|------|-------------------------|
| Brown     | Blue    | 188-282 |      | 135 V Minimum           |

5. Check the resistance and DVA output of the Triggers:

| Read from                | Read to       | Reading | Ohms | DVA (connected to pack) |
|--------------------------|---------------|---------|------|-------------------------|
| White/Red Trigger wire   | Engine ground | 260-390 |      | 2 V Minimum             |
| White/Black Trigger wire | Engine ground | 260-390 |      | 2 V Minimum             |

6. Check the cranking RPM. A cranking speed of less than 250-RPM will not allow the system to fire properly.

### NO SPARK OR INTERMITTENT ON ONE OR MORE CYLINDERS:

1. Check the resistance and DVA output of the stator plate assembly:

| Read from                | Read to       | Reading | Ohms | DVA (connected to pack) |
|--------------------------|---------------|---------|------|-------------------------|
| White/Red Trigger wire   | Engine ground | 260-390 |      | 2 V Minimum             |
| White/Black Trigger wire | Engine ground | 260-390 |      | 2 V Minimum             |

2. Check the DVA output on the Black/White wires from the power pack while connected to the ignition coils, reference to engine ground. You should read 120 V Minimum.
3. Swap the coils. If the problem moves to the other cylinder, replace the coil. If the problem stays on the cylinder, re-check the trigger coils.

### HAS SPARK BUT WILL NOT RUN:

- Make sure the engine is getting fuel to the combustion chamber (make sure there is no water or residue in the carburetor). Check to see if a high ethanol content is present. . If so, purge the fuel system with fresh fuel and see if the engine will start.
- Check the fuel pressure AT THE CARBURETOR. You should see over 2 PSI. Check fuel lines for inner wall breakdown and wall collapse.
- Check flywheel shear key to make sure it has not sheared due to backfiring or impact on the propeller.
- Check spark plugs for presence of water, indicating a possible cracked block or blown head gasket.
- Check compression, carburetor, reeds and do a cylinder leak down test.
- Check the Blanker coil as follows as a defective Blanker coil can cause timing variance or not fire:

| Check From: | Check To:     | Ohms Reading: | DVA Reading:     |
|-------------|---------------|---------------|------------------|
| Yellow      | Engine ground | 25-35 ohms    | 10 Volts Minimum |

### WILL NOT STOP (KILL):

Short the White wire from the CD Module to engine ground. If the engine stops, the problem is in the stop circuit. If the engine continues to run with the White wire shorted to engine ground, replace the defective CD Module.

## P60 HP (3 Cyl) 1991 E60 (3 Cyl) 1995-2000 6H3-85540-11-00/117-6H3-11

### NO SPARK ON ANY CYLINDER:

- Disconnect the White stop wire and retest. If the engine's ignition now has spark, the stop circuit has a fault-check the key switch, harness and shift switch.
- Inspect and clean all engine and ignition ground connections.
- Verify the correct spark plugs are installed.
- Check the resistance and DVA output of the Stator and Trigger:

| Read from                | Read to           | Ohm Reading | DVA (connected) | DVA (Disconnected) |
|--------------------------|-------------------|-------------|-----------------|--------------------|
| White/Red Trigger wire   | Black wire        | 104-156     | 2.5 V Minimum   | 4.5 V Minimum      |
| White/Black Trigger wire | Black wire        | 104-156     | 2.5 V Minimum   | 4.5 V Minimum      |
| White/Green Trigger wire | Black wire        | 104-156     | 2.5 V Minimum   | 4.5 V Minimum      |
| Brown Stator wire        | Black Stator wire | 45-198      | 140 V Minimum   | 170 V Minimum      |
| Black/White              | Engine Ground     | -           | 100 V Minimum   |                    |

5. Check the cranking RPM. A cranking speed of less than 250-RPM may not allow the system to fire properly.

## **Yamaha Troubleshooting**

### **NO SPARK OR INTERMITTENT ON ONE OR MORE CYLINDERS:**

1. Check the resistance and DVA output of the Trigger:

| Read from                 | Read to           | Ohm Reading | DVA (connected) | DVA (Disconnected) |
|---------------------------|-------------------|-------------|-----------------|--------------------|
| White/Red Trigger wire    | Black wire        | 104-156     | 2.5 V Minimum   | 4.5 V Minimum      |
| White/Black Trigger wire  | Black wire        | 104-156     | 2.5 V Minimum   | 4.5 V Minimum      |
| White/Green Trigger wire  | Black wire        | 104-156     | 2.5 V Minimum   | 4.5 V Minimum      |
| Brown Stator wire         | Black Stator wire | 145-198     | 140 V Minimum   | 170 V Minimum      |
| Black/White (Pack Output) | Engine Ground     | -           | 100 V Minimum   |                    |
| Black/White (Coil)        | Black             | 3.84K-5.76K |                 |                    |

2. Swap the problem coil with another coil. If the problem moves with the coil, the ignition coil is likely bad.

### **ENGINE WILL NOT ACCELERATE ABOVE APPROXIMATELY 2000 RPM:**

1. Verify the engine is not overheating and causing the power pack to limit the RPM.
2. Disconnect the Pink wire from the power pack and retest. If the engine now performs correctly, check the overheat sensor, oil level in the oil tank mounted on the engine and the wiring harness.
3. Check the position of the Pink wire and make sure it is not next to a spark plug wire.
4. Verify the ignition timing is advancing to the WOT setting (18-20 Degrees BTDC).

### **ENGINE WILL NOT ACCELERATE ABOVE APPROXIMATELY 2500 RPM:**

1. Using an inductive tachometer, check the RPM on all cylinders. A difference in readings between the individual cylinders can be caused by a bad coil, power pack or spark plug.
2. If all cylinders show the same RPM and the engine will only rev to approximately 2500 RPM, check the running stator DVA output from idle thru WOT. You should show an increase in voltage on the Blue to the Brown stator wires, stabilizing over 2000 RPM and showing a slight decrease over 5000 RPM. A sharp drop in voltage can be the result of a bad stator coil or a bad pack.

### **HIGH SPEED MISS:**

1. Verify the engine is not overheating and causing the problem.
2. Using an inductive tachometer, check the RPM on all cylinders. A difference in readings between the individual cylinders can be caused by a bad coil, power pack or spark plug.

### **S.A.F.E. WILL NOT ENGAGE:**

Disconnect the Pink warning wire from the power pack. Connect a jumper wire to engine ground and connect it to the Pink wire from the power pack (If it still fails to engage, the power pack is likely bad). If the engine now limits at approximately 2000 RPM, check the wiring from the temperature sensor and oil tank to the power pack.

### **ENGINE WILL NOT STOP RUNNING:**

Connect a jumper wire to the White wire from the ignition pack to engine ground. If you still have spark, the power pack is likely bad. If the engine has no spark with the jumper connected, either the wiring harness, keyswitch or emergency stop switch is bad.

**60 HP (3 Cyl) 2001-2005**  
**C60 HP (3 Cyl) 1996-2001**  
**P60 HP (3 Cyl) 1992-1999**  
**6H2-85540-13-00**

### **NO SPARK ON ANY CYLINDER:**

1. Disconnect the White stop wire and retest. If the engine's ignition now has spark, the stop circuit has a fault- check the key switch, harness and shift switch.
2. Inspect and clean all engine and ignition ground connections.
3. Verify the correct spark plugs are installed.

4. Check the resistance and DVA output of the Stator and Trigger:

| Read from              | Read to          | OEM Reading  | DVA (connected)       | DVA (Disconnected) |
|------------------------|------------------|--------------|-----------------------|--------------------|
| White/Red Trigger wire | White/Black wire | 260-360 ohms | 2.5 V Minimum         | 4.5 V Minimum      |
| Brown Stator wire      | Blue Stator wire | 136-204 ohms | 150 V Minimum         | 120 V Minimum      |
| Black//Orange (#1)     | Engine Ground    | -            | 105 V Minimum         |                    |
| Black/White (#2)       | Engine Ground    | -            | 0 V Minimum (at idle) |                    |
| Black/Yellow (#3)      | Engine Ground    | -            | 105 V Minimum         |                    |

NOTE: The #2 Cylinder is triggered by the ignition pack, it is normal for it to have no fire at cranking or idling. All cylinders should fire at 1500 RPM.

5. Check the cranking RPM. A cranking speed of less than 250-RPM may not allow the system to fire properly.

#### **NO SPARK OR INTERMITTENT ON ONE OR MORE CYLINDERS:**

1. Check the resistance and DVA output:

| Read from                        | Read to          | OEM Reading  | DVA (connected) | DVA (Disconnected) |
|----------------------------------|------------------|--------------|-----------------|--------------------|
| White/Red Trigger wire           | White/Black wire | 260-360 ohms | 2.5 V Minimum   | 4.5 V Minimum      |
| Blue/Red (Crank Position Sensor) | Blue/White       | 136-204      | 5 V Minimum     |                    |
| Black/Orange                     | Engine Ground    | -            | -               | 125 V Minimum      |
| Black/White                      | Engine Ground    | -            | -               | 0 V (at idle)      |
| Black/Yellow                     | Engine Ground    | -            | -               | 125 V Minimum      |
| Coil High Tension Lead           | Black            |              | 3.28K-4.92K     |                    |

NOTE: The #2 Cylinder is triggered by the ignition pack, it is normal for it to have no fire at cranking or idling. All cylinders should fire at 1500 RPM.

2. Swap the coils. If the problem moves to the other cylinder, replace the coil. If the problem stays on the cylinder, re-check the trigger coils.

#### **ENGINE WILL NOT ACCELERATE ABOVE APPROXIMATELY 2000 RPM:**

1. Verify the engine is not overheating and causing the power pack to limit the RPM.
2. Disconnect the Pink wire from the power pack and retest. If the engine now performs correctly, check the overheat sensor, oil level in the oil tank mounted on the engine and the wiring harness.
3. Check the position of the Pink wire and make sure it is not next to a spark plug wire.
4. Verify the ignition timing is advancing to the WOT setting (24-28 Degrees BTDC).

#### **ENGINE WILL NOT ACCELERATE ABOVE APPROXIMATELY 2500 RPM:**

1. Using an inductive tachometer, check the RPM on all cylinders. A difference in readings between the individual cylinders can be caused by a bad coil, power pack or spark plug.
2. If all cylinders show the same RPM and the engine will only rev to approximately 2500 RPM, check the running stator DVA output from idle thru WOT. You should show an increase in voltage on the Blue to the Brown stator wire, stabilizing over 2000 RPM and showing a slight decrease over 5000 RPM. A sharp drop in voltage can be the result of a bad stator coil or a bad pack.

#### **HIGH SPEED MISS:**

1. Verify the engine is not overheating and causing the problem.
2. Using an inductive tachometer, check the RPM on all cylinders. A difference in readings between the individual cylinders can be caused by a bad coil, power pack or spark plug.

#### **S.A.F.E. WILL NOT ENGAGE:**

Disconnect the Pink warning wire from the power pack. Connect a jumper wire to engine ground and connect it to the Pink wire from the power pack (If it still fails to engage, the power pack is likely bad). If the engine now limits at approximately 2000 RPM, check the wiring from the temperature sensor and oil tank to the power pack.

#### **ENGINE WILL NOT STOP RUNNING:**

Short the White wire from the CD Module to engine ground. If the engine stops, the problem is in the stop circuit. If the engine continues to run with the White wire shorted to engine ground, replace the defective CD Module.



# Yamaha Troubleshooting

## C70 HP (3 Cyl) 1994-2000 6H3-85540-11-00/117-6H3-11

### NO SPARK ON ANY CYLINDER:

1. Disconnect the White stop wire and retest. If the engine's ignition now has spark, the stop circuit has a fault-check the key switch, harness and shift switch.
2. Inspect and clean all engine and ignition ground connections.
3. Verify the correct spark plugs are installed.
4. Check the resistance and DVA output of the Stator and Trigger:

| Read from                | Read to           | Ohm Reading | DVA (connected) | DVA           |
|--------------------------|-------------------|-------------|-----------------|---------------|
| <u>(Disconnected)</u>    |                   |             |                 |               |
| White/Red Trigger wire   | Black wire        | 104-156     | 2.5 V Minimum   | 4.5 V Minimum |
| White/Black Trigger wire | Black wire        | 104-156     | 2.5 V Minimum   | 4.5 V Minimum |
| White/Green Trigger wire | Black wire        | 104-156     | 2.5 V Minimum   | 4.5 V Minimum |
| Brown Stator wire        | Black Stator wire | 145-198     | 140 V Minimum   | 170 V Minimum |
| Black/White              | Engine Ground     | -           | 100 V Minimum   |               |

### NO SPARK OR INTERMITTENT ON ONE OR MORE CYLINDERS:

1. Check the resistance and DVA output of the Trigger:

| Read from                 | Read to       | Ohm Reading | DVA (connected) | DVA           |
|---------------------------|---------------|-------------|-----------------|---------------|
| <u>(Disconnected)</u>     |               |             |                 |               |
| White/Red Trigger wire    | Black wire    | 104-156     | 2.5 V Minimum   | 4.5 V Minimum |
| White/Black Trigger wire  | Black wire    | 104-156     | 2.5 V Minimum   | 4.5 V Minimum |
| White/Green Trigger wire  | Black wire    | 104-156     | 2.5 V Minimum   | 4.5 V Minimum |
| Brown Stator wire         | Black wire    | 145-198     | 140 V Minimum   | 170 V Minimum |
| Black/White (Pack Output) | Engine Ground | -           | 100 V Minimum   |               |
| Black/White (Coil)        | Black         | 3.84K-5.76K |                 |               |

2. Swap the problem coil with another coil. If the problem moves with the coil, the ignition coil is likely bad.

### ENGINE WILL NOT ACCELERATE ABOVE APPROXIMATELY 2000 RPM:

1. Verify the engine is not overheating and causing the power pack to limit the RPM.
2. Disconnect the Pink wire from the power pack and retest. If the engine now performs correctly, check the overheat sensor, oil level in the oil tank mounted on the engine and the wiring harness.
3. Verify the ignition timing is advancing to the WOT setting (18-20 Degrees BTDC).

### ENGINE WILL NOT ACCELERATE ABOVE APPROXIMATELY 2500 RPM:

1. Using an inductive tachometer, check the RPM on all cylinders. A difference in readings between the individual cylinders can be caused by a bad coil, power pack or spark plug.
2. If all cylinders show the same RPM and the engine will only rev to approximately 2500 RPM, check the running stator DVA output from idle thru WOT. You should show an increase in voltage on the Blue to the Brown stator wires, stabilizing and showing a slight decrease over 5000 RPM. A sharp drop in voltage can be the result of a bad stator coil or a bad pack.

### HIGH SPEED MISS:

1. Verify the engine is not overheating and causing the problem.
2. Using an inductive tachometer, check the RPM on all cylinders. A difference in readings between the individual cylinders can be caused by a bad coil, power pack or spark plug.

### S.A.F.E. WILL NOT ENGAGE:

Disconnect the Pink warning wire from the power pack. Connect a jumper wire to engine ground and connect it to the Pink wire from the power pack (If it still fails to engage, the power pack is likely bad). If the engine now limits at approximately 2000 RPM, check the wiring from the temperature sensor and oil tank to the power pack.

### ENGINE WILL NOT STOP RUNNING:

Short the White wire from the CD Module to engine ground. If the engine stops, the problem is in the stop circuit. If the engine continues to run with the White wire shorted to engine ground, replace the defective CD Module.

**C70 HP (3 Cyl) 2001**  
**6H2-85540-13-00**

**NO SPARK ON ANY CYLINDER:**

1. Disconnect the White stop wire and retest. If the engine's ignition now has spark, the stop circuit has a fault-check the key switch, harness and shift switch.
2. Inspect and clean all engine and ignition ground connections.
3. Check the resistance and DVA output of the Stator and Trigger:

| Read from                  | Read to          | Ohm Reading | DVA (connected)       | DVA (Disconnected) |
|----------------------------|------------------|-------------|-----------------------|--------------------|
| White/Red Trigger wire     | White/Black wire | 260-360     | 2.5 V Minimum         | 4.5 V Minimum      |
| Brown Stator wire          | Blue Stator wire | 136-204     | 150 V Minimum         | 120 V Minimum      |
| Blk//Org (#1) & Blk/Yel #3 | Engine Ground    | -           | 105 V Minimum         |                    |
| Black/White (#2)           | Engine Ground    | -           | 0 V Minimum (at idle) |                    |

NOTE: The #2 Cylinder is triggered by the ignition pack, it is normal for it to have no fire under 1500 RPM.

**NO SPARK OR INTERMITTENT ON ONE OR MORE CYLINDERS:**

1. Check the resistance and DVA output of the Trigger:

| Read from                        | Read to          | Ohm Reading | DVA (connected) | DVA (Disconnected) |
|----------------------------------|------------------|-------------|-----------------|--------------------|
| White/Red Trigger wire           | White/Black wire | 260-360     | 2.5 V Minimum   | 4.5 V Minimum      |
| Blue/Red (Crank Position Sensor) | Blue/White       | 136-204     | 5 V Minimum     |                    |
| Black/Orange                     | Engine Ground    | -           | 125 V Minimum   |                    |
| Black/White                      | Engine Ground    | -           | 0 V (at idle)   |                    |
| Black/Yellow                     | Engine Ground    | -           | 125 V Minimum   |                    |

NOTE: The #2 Cylinder is triggered by the ignition pack, it is normal for it to have no fire at cranking or idling. All cylinders should fire by 1500 RPM.

2. If the reading is low on one cylinder, disconnect the wire from the ignition coil for that cylinder and reconnect it to a load resistor. Retest. If the reading is now good, the ignition coil is likely bad. A continued low reading indicates a bad power pack or trigger (test per above).

**ENGINE WILL NOT ACCELERATE ABOVE APPROXIMATELY 2000 RPM:**

1. Verify the engine is not overheating and causing the power pack to limit the RPM.
2. Disconnect the Pink wire from the power pack and retest. If the engine now performs correctly, check the overheat sensor, oil level in the oil tank mounted on the engine and the wiring harness.
3. Verify the ignition timing is advancing to the WOT setting (24-28 Degrees BTDC).

**ENGINE WILL NOT ACCELERATE ABOVE APPROXIMATELY 2500 RPM:**

1. Using an inductive tachometer, check the RPM on all cylinders. A difference in readings between the individual cylinders can be caused by a bad coil, power pack or spark plug.
2. If all cylinders show the same RPM and the engine will only rev to approximately 2500 RPM, check the running stator DVA output from idle thru WOT. You should show an increase in voltage on the Blue to the Brown stator wires, stabilizing over 2000 RPM and showing a slight decrease over 5000 RPM. A sharp drop in voltage can be the result of a bad stator coil or a bad pack.

**HIGH SPEED MISS:**

1. Verify the engine is not overheating and causing the problem.
2. Using an inductive tachometer, check the RPM on all cylinders. A difference in readings between the individual cylinders can be caused by a bad coil, power pack or spark plug.

**S.A.F.E. WILL NOT ENGAGE:**

Disconnect the Pink warning wire from the power pack. Connect a jumper wire to engine ground and connect it to the Pink wire from the power pack (If it still fails to engage, the power pack is likely bad). If the engine now limits at approximately 2000 RPM, check the wiring from the temperature sensor and oil tank to the power pack.

**ENGINE WILL NOT STOP RUNNING:**

## **Yamaha Troubleshooting**

Disconnect the White kill wire and connect a jumper wire from the White wire to engine ground. If you still have spark, the power pack is likely bad. If the engine has no spark with the jumper connected, either the wiring harness, keyswitch or emergency stop switch is bad.

### **70 HP (3 Cyl) 1984-1991 6H3-85540-11-00**

#### **NO SPARK ON ANY CYLINDER:**

1. Disconnect the White stop wire and retest. If the engine's ignition now has spark, the stop circuit has a fault-check the key switch, harness and shift switch.
2. Inspect and clean all engine and ignition ground connections.
3. Check the resistance and DVA output of the Stator and Trigger:

| Read from                | Read to          | Ohm Reading | DVA (connected) | DVA (Disconnected) |
|--------------------------|------------------|-------------|-----------------|--------------------|
| White/Red Trigger wire   | Black wire       | 104-156     | 2.5 V Minimum   | 2.7 V Minimum      |
| White/Black Trigger wire | Black wire       | 104-156     | 2.5 V Minimum   | 2.7 V Minimum      |
| White/Green Trigger wire | Black wire       | 104-156     | 2.5 V Minimum   | 2.7 V Minimum      |
| Brown Stator wire        | Blue Stator wire | 128-197     | 140 V Minimum   | 170 V Minimum      |
| Black//Orange (#1)       | Engine Ground    | -           | 100 V Minimum   |                    |
| Black/White (#2)         | Engine Ground    | -           | 100 V Minimum   |                    |
| Black/Yellow (#3)        | Engine Ground    | -           | 100 V Minimum   |                    |

4. Check the cranking RPM. A cranking speed of less than 250-RPM may not allow the system to fire properly.

#### **NO SPARK OR INTERMITTENT ON ONE OR MORE CYLINDERS:**

1. Check the resistance and DVA output of the Trigger:

| Read from                | Read to       | Ohm Reading | DVA (connected) | DVA (Disconnected) |
|--------------------------|---------------|-------------|-----------------|--------------------|
| White/Red Trigger wire   | Black wire    | 104-156     | 2.5 V Minimum   | 2.7 V Minimum      |
| White/Black Trigger wire | Black wire    | 104-156     | 2.5 V Minimum   | 2.7 V Minimum      |
| White/Green Trigger wire | Black wire    | 104-156     | 2.5 V Minimum   | 2.7 V Minimum      |
| Black/Orange (#1)        | Engine Ground | -           | 100 V Minimum   |                    |
| Black/White (#2)         | Engine Ground | -           | 100 V Minimum   |                    |
| Black/Yellow (#3)        | Engine Ground | -           | 100 V Minimum   |                    |

2. Check the DVA output on the Black/Orange, Black/White and Black/Yellow wires from the power pack while connected to the ignition coils. You should have a reading of at least 125V or more. If the reading is low on one cylinder, disconnect the wire from the ignition coil for that cylinder and reconnect it to a load resistor. Retest. If the reading is now good, the ignition coil is likely bad. A continued low reading indicates a bad power pack or trigger (test per above).

#### **ENGINE WILL NOT ACCELERATE ABOVE APPROXIMATELY 2000 RPM:**

1. Verify the engine is not overheating and causing the power pack to limit the RPM.
2. Disconnect the Pink wire from the power pack and retest. If the engine now performs correctly, check the overheat sensor, oil level in the oil tank mounted on the engine and the wiring harness.
3. Check the position of the Pink wire and make sure it is not next to a spark plug wire.
4. Verify the ignition timing is advancing to the WOT setting (18-20 Degrees BTDC).

#### **ENGINE WILL NOT ACCELERATE ABOVE APPROXIMATELY 2500 RPM:**

1. Using an inductive tachometer, check the RPM on all cylinders. A difference in readings between the individual cylinders can be caused by a bad coil, power pack or spark plug.
2. If all cylinders show the same RPM and the engine will only rev to approximately 2500 RPM, check the running stator DVA output from idle thru WOT. You should show an increase in voltage on the Blue to the Brown stator wires, stabilizing over 2000 RPM and showing a slight decrease over 5000 RPM. A sharp drop in voltage can be the result of a bad stator coil or a bad pack.

#### **HIGH SPEED MISS:**

1. Verify the engine is not overheating and causing the problem.
2. Using an inductive tachometer, check the RPM on all cylinders. A difference in readings between the individual cylinders can be caused by a bad coil, power pack or spark plug.

## Yamaha Troubleshooting

### S.A.F.E. WILL NOT ENGAGE:

Disconnect the Pink warning wire from the power pack. Connect a jumper wire to engine ground and connect it to the Pink wire from the power pack (If it still fails to engage, the power pack is likely bad). If the engine now limits at approximately 2000 RPM, check the wiring from the temperature sensor and oil tank to the power pack.

### ENGINE WILL NOT STOP RUNNING:

Disconnect the White kill wire and connect a jumper wire from the White wire to engine ground. If you still have spark, the power pack is likely bad. If the engine has no spark with the jumper connected, either the wiring harness, keyswitch or emergency stop switch is bad.

### 70 HP (3 Cyl) 1992-2009 6H2-85540-13-00

#### NO SPARK ON ANY CYLINDER:

1. Disconnect the White stop wire and retest. If the engine's ignition now has spark, the stop circuit has a fault-check the key switch, harness and shift switch.
2. Inspect and clean all engine and ignition ground connections.
3. Check the resistance and DVA output of the Stator and Trigger:

| Read from              | Read to          | Ohm Reading | DVA (connected) | DVA           |
|------------------------|------------------|-------------|-----------------|---------------|
| <u>(Disconnected)</u>  |                  |             |                 |               |
| White/Red Trigger wire | White/Black wire | 260-360     | 2.5 V Minimum   | 4.5 V Minimum |
| Brown Stator wire      | Blue Stator wire | 136-204     | 150 V Minimum   | 120 V Minimum |
| Black//Orange (#1)     | Engine Ground    | -           | 105 V Minimum   |               |
| Black/White (#2)       | Engine Ground    | -           | 0 V (at idle)   |               |
| Black/Yellow (#3)      | Engine Ground    | -           | 105 V Minimum   |               |

NOTE: The #2 Cylinder is triggered by the ignition pack, it is normal for it to have no fire at cranking or idling. All cylinders should fire by 1500 RPM.

4. Check the cranking RPM. A cranking speed of less than 250-RPM may not allow the system to fire properly.

#### NO SPARK OR INTERMITTENT ON ONE OR MORE CYLINDERS:

1. Check the resistance and DVA output of the Trigger:

| Read from                        | Read to          | Ohm Reading | DVA (connected) | DVA           |
|----------------------------------|------------------|-------------|-----------------|---------------|
| <u>(Disconnected)</u>            |                  |             |                 |               |
| White/Red Trigger wire           | White/Black wire | 260-360     | 2.5 V Minimum   | 4.5 V Minimum |
| Blue/Red (Crank Position Sensor) | Blue/White       | 136-204     | 5 V Minimum     |               |
| Black/Orange                     | Engine Ground    | -           | 125 V Minimum   |               |
| Black/White                      | Engine Ground    | -           | 0 V Minimum     |               |
| Black/Yellow                     | Engine Ground    | -           | 125 V Minimum   |               |

NOTE: The #2 Cylinder is triggered by the ignition pack, it is normal for it to have no fire at cranking or idling. All cylinders should fire at 1500 RPM.

2. If the reading is low on one cylinder, disconnect the wire from the ignition coil for that cylinder and reconnect it to a load resistor. Retest. If the reading is now good, the ignition coil is likely bad. A continued low reading indicates a bad power pack or trigger (test per above).

#### ENGINE WILL NOT ACCELERATE ABOVE APPROXIMATELY 2000 RPM:

1. Verify the engine is not overheating and causing the power pack to limit the RPM.
2. Disconnect the Pink wire from the power pack and retest. If the engine now performs correctly, check the overheat sensor, oil level in the oil tank mounted on the engine and the wiring harness.
3. Check the position of the Pink wire and make sure it is not next to a spark plug wire.
4. Verify the ignition timing is advancing to the WOT setting (24-28 Degrees BTDC).

#### ENGINE WILL NOT ACCELERATE ABOVE APPROXIMATELY 2500 RPM:

1. Using an inductive tachometer, check the RPM on all cylinders. A difference in readings between the individual cylinders can be caused by a bad coil, power pack or spark plug.
2. If all cylinders show the same RPM and the engine will only rev to approximately 2500 RPM, check the running

## **Yamaha Troubleshooting**

stator DVA output from idle thru WOT. You should show an increase in voltage on the Blue to the Brown stator wires, stabilizing over 2000 RPM and showing a slight decrease over 5000 RPM. A sharp drop in voltage can be the result of a bad stator coil or a bad pack.

### **HIGH SPEED MISS:**

1. Verify the engine is not overheating and causing the problem.
2. Using an inductive tachometer, check the RPM on all cylinders. A difference in readings between the individual cylinders can be caused by a bad coil, power pack or spark plug.

### **S.A.F.E. WILL NOT ENGAGE:**

Disconnect the Pink warning wire from the power pack. Connect a jumper wire to engine ground and connect it to the Pink wire from the power pack (If it still fails to engage, the power pack is likely bad). If the engine now limits at approximately 2000 RPM, check the wiring from the temperature sensor and oil tank to the power pack.

### **ENGINE WILL NOT STOP RUNNING:**

Disconnect the White kill wire and connect a jumper wire from the White wire to engine ground. If you still have spark, the power pack is likely bad. If the engine has no spark with the jumper connected, either the wiring harness, keyswitch or emergency stop switch is bad.

**C75 HP (3 Cyl) 1994-1996**  
**E75 HP (3 Cyl) 1995-1996**  
**CV85 HP (3 Cyl) 1989-1996**  
**C85 HP (3 Cyl) 1991-1996**  
**90 HP (3 Cyl) 1985-1991**

**688-85540-15-00/688-85540-16-00**

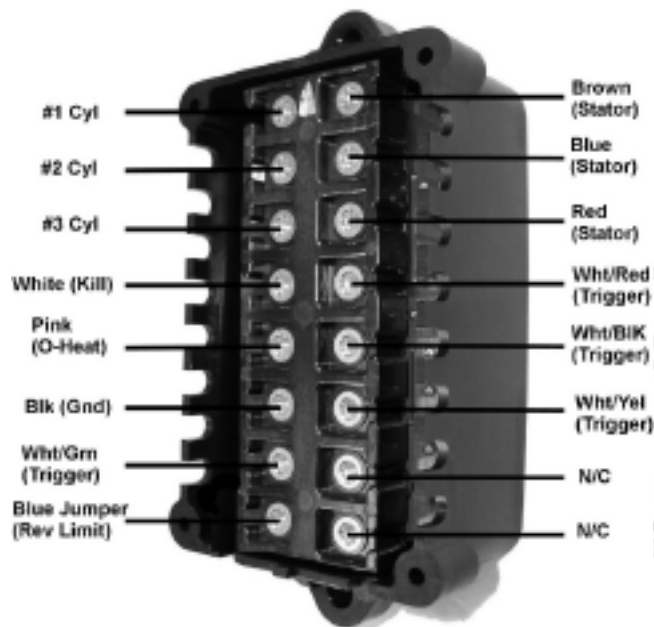

### **NO SPARK ON ANY CYLINDER:**

1. Disconnect the White stop wire and retest. If the engine's ignition now has spark, the stop circuit has a fault. Check the key switch, harness and shift switch.
2. Inspect and clean all engine and ignition ground connections.



## Yamaha Troubleshooting

3. Check the resistance and DVA output of the Stator and Trigger:

| Read from                | Read to                    | OEM Reading   | CDI Reading  | DVA (connected) |
|--------------------------|----------------------------|---------------|--------------|-----------------|
| White/Red Trigger wire   | White/Yellow Trigger wire  | 280-430 ohms  | 280-430 ohms | 2.5 V Minimum   |
| White/Black Trigger wire | White/Green Trigger wire   | 280-430 ohms  | 280-430 ohms | 2.5 V Minimum   |
| Brown Stator wire        | Blue Stator wire (1984-89) | 680-1020 ohms | 600-800 ohms | 85 V Minimum    |
| Brown Stator wire        | Blue Stator wire (1990-96) | 840-1260 ohms | 600-800 ohms | 85 V Minimum    |
| Blue Stator wire         | Red Stator wire            | 96-144ohms    | 10-20 ohms   | 25 V Minimum    |

4. Check the cranking RPM. A cranking speed of less than 250-RPM will not allow the system to spark properly. This can be caused by a weak battery, dragging starter, bad battery cables or a mechanical problem inside the engine properly.

### NO SPARK OR INTERMITTENT SPARK ON ONE OR MORE CYLINDERS:

1. Check the resistance and DVA output of the Stator and Trigger:

| Read from                 | Read to                    | OEM Reading   | CDI Reading  | DVA (connected) |
|---------------------------|----------------------------|---------------|--------------|-----------------|
| White/Red Trigger wire    | White/Yellow Trigger wire  | 280-430 ohms  | 280-430 ohms | 2.5 V Minimum   |
| White/Black Trigger wire  | White/Green Trigger wire   | 280-430 ohms  | 280-430 ohms | 2.5 V Minimum   |
| White/Red Trigger wire    | Eng Ground                 | Open          | Open         | 2.5 V Minimum   |
| White/Black Trigger wire  | Eng Ground                 | Open          | Open         | 2.5 V Minimum   |
| White/Yellow Trigger wire | Eng Ground                 | Open          | Open         | 2.5 V Minimum   |
| White/Green Trigger wire  | Eng Ground                 | Open          | Open         | 2.5 V Minimum   |
| Brown Stator wire         | Blue Stator wire (1984-89) | 680-1020 ohms | 600-800 ohms | 85 V Minimum    |
| Brown Stator wire         | Blue Stator wire (1990-96) | 840-1260 ohms | 600-800 ohms | 85 V Minimum    |
| Brown Stator wire         | Eng Ground                 | Open          | Open         | 85 V Minimum    |
| Blue Stator wire          | Eng Ground                 | Open          | Open         | 16 V Minimum    |
| Blue Stator wire          | Red Stator wire            | 96-144 ohms   | 10-20 ohms   | 25 V Minimum    |
| Red Stator wire           | Eng Ground                 | Open          | Open         | 30 V Minimum    |

2. Check the DVA output on the Black/White wires from the power pack while connected to the ignition coils. You should have a reading of at least 85V or more. If the reading is low on one cylinder, disconnect the wire from the ignition coil for that cylinder and reconnect it to a load resistor. Retest. If the reading is now good, the ignition coil is likely bad. A continued low reading indicates a bad power pack or trigger (test per above).

### ENGINE WILL NOT ACCELERATE ABOVE APPROXIMATELY 2000 RPM:

1. Verify the engine is not overheating and causing the power pack to limit the RPM.
2. Disconnect the Pink wire from the power pack and retest. If the engine now performs correctly, check the overheat sensor, oil level in the oil tank mounted on the engine and the wiring harness.
3. Check the position of the Pink wire and make sure it is not next to a spark plug wire.

### ENGINE WILL NOT ACCELERATE ABOVE APPROXIMATELY 2500 RPM:

1. Using an inductive tachometer, check the RPM on all cylinders. A difference in readings between the individual cylinders can be caused by a bad coil, power pack or spark plug.
2. If all cylinders show the same RPM and the engine will only rev to approximately 2500 RPM, check the running stator DVA output from idle thru WOT. You should show an increase in voltage on the Blue to the Black/Red stator wires throughout the RPM range until it peaks out at approximately 300 Volts. A drop in voltage can be the result of a bad stator coil or a bad regulator/rectifier (disconnect the Green wires to the regulator/rectifier and retest – if the engine now performs OK, the regulator/rectifier is likely bad).

### MISS AT ANY RPM:

1. Verify the engine is not overheating and causing the problem.
2. Using an inductive tachometer, check the RPM on all cylinders. A difference in readings between the individual cylinders can be caused by a bad coil, power pack or spark plug.
3. Disconnect the Green wires to the regulator/rectifier and retest – if the engine now performs OK, the regulator/rectifier is likely bad.

### S.A.F.E. WILL NOT ENGAGE:

Disconnect the Pink warning wire from the power pack. Connect a jumper wire to engine ground and connect it to

## Yamaha Troubleshooting

the terminal where the Pink wire goes. If the engine now limits at approximately 2000 RPM, check the wiring from the temperature sensor and oil tank to the power pack. If it still fails to engage, the power pack is likely bad.

### ENGINE WILL NOT STOP:

Disconnect the White stop wire and connect a jumper wire to engine ground. If you still have spark, the power pack is likely bad. If the engine has no spark with the jumper connected, either the wiring harness, key switch or emergency stop switch is bad.

**C75 (3 Cyl) 1998-1999**

**P75 (3 Cyl) 1996-1999**

**C80 (3 Cyl) 1997**

**C90 (3 Cyl) 1997-2001**

**90 (3 Cyl) 1992-2009**

**6H0-85540-07-00**

### NO SPARK ON ANY CYLINDER:

1. Disconnect the White stop wire and retest. If the engine's ignition now has spark, the stop circuit has a fault-check the key switch, harness and shift switch.
2. Inspect and clean all engine and ignition ground connections.
3. Check the resistance and DVA output of the Stator and Trigger:

| Read from                   | Read to          | Ohm Reading | DVA (connected) | DVA (Disconnected) |
|-----------------------------|------------------|-------------|-----------------|--------------------|
| White/Red Trigger wire      | White/Black wire | 241-362     | 5 V Minimum     | 7 V Minimum        |
| Brown Stator wire           | Red Stator wire  | 191-288     | 100 V Minimum   | 90 V Minimum       |
| Blue Stator wire            | Red Stator wire  | 64-96       | 60 V Minimum    | 55 V Minimum       |
| Black//Orange (#1)          | Engine Ground    | -           | 130 V Minimum   |                    |
| Black/White (#2)            | Engine Ground    | -           | 0 V (at idle)   |                    |
| Black/Yellow (#3)           | Engine Ground    | -           | 130 V Minimum   |                    |
| Blue/White (Crank Position) | Blue/Red         | 158-236     | 5.5 V Minimum   | 5.5 V Minimum      |

NOTE: The #2 Cylinder is triggered by the ignition pack, it is normal for it to have no fire at cranking or idling. All cylinders should fire by 1500 RPM.

4. Check the cranking RPM. A cranking speed of less than 250-RPM may not allow the system to fire properly.

### NO SPARK OR INTERMITTENT ON ONE OR MORE CYLINDERS:

1. Check the resistance and DVA output of the Trigger:

| Read from              | Read to          | Ohm Reading  | DVA (connected) | DVA (Disconnected) |
|------------------------|------------------|--------------|-----------------|--------------------|
| White/Red Trigger wire | White/Black wire | 241-362 ohms | 5 V Minimum     | 7 V Minimum        |
| Blue/Red               | Blue/White       | 158-236      | 5.5 V Minimum   |                    |
| Black/Orange           | Engine Ground    | -            | 130 V Minimum   |                    |
| Black/White            | Engine Ground    | -            | 0 V Minimum     |                    |
| Black/Yellow           | Engine Ground    | -            | 130 V Minimum   |                    |

NOTE: The #2 Cylinder is triggered by the ignition pack, it is normal for it to have no fire at cranking or idling. All cylinders should fire by 1500 RPM.

2. If the reading is low on one cylinder, disconnect the wire from the ignition coil for that cylinder and reconnect it to a load resistor. Retest. If the reading is now good, the ignition coil is likely bad. A continued low reading indicates a bad power pack or trigger (test per above).

### ENGINE WILL NOT ACCELERATE ABOVE APPROXIMATELY 2000 RPM:

1. Verify the engine is not overheating and causing the power pack to limit the RPM.
2. Disconnect the Pink wire from the power pack and retest. If the engine now performs correctly, check the overheat sensor, oil level in the oil tank mounted on the engine and the wiring harness.
3. Check the position of the Pink wire and make sure it is not next to a spark plug wire.
4. Verify the ignition timing is advancing to the WOT setting (19-21 Degrees BTDC).

## Yamaha Troubleshooting

### ENGINE WILL NOT ACCELERATE ABOVE APPROXIMATELY 2500 RPM:

1. Using an inductive tachometer, check the RPM on all cylinders. A difference in readings between the individual cylinders can be caused by a bad coil, power pack or spark plug.
2. If all cylinders show the same RPM and the engine will only rev to approximately 2500 RPM, check the running stator DVA output from idle thru WOT. You should show an increase in voltage on the Blue to the Brown stator wires, stabilizing over 2000 RPM and showing a slight decrease over 5000 RPM. A sharp drop in voltage can be the result of a bad stator coil or a bad pack.

### HIGH SPEED MISS:

1. Verify the engine is not overheating and causing the problem.
2. Using an inductive tachometer, check the RPM on all cylinders. A difference in readings between the individual cylinders can be caused by a bad coil, power pack or spark plug.

### S.A.F.E. WILL NOT ENGAGE:

Disconnect the Pink warning wire from the power pack. Connect a jumper wire to engine ground and connect it to the Pink wire from the power pack (If it still fails to engage, the power pack is likely bad). If the engine now limits at approximately 2000 RPM, check the wiring from the temperature sensor and oil tank to the power pack.

### ENGINE WILL NOT STOP RUNNING:

Disconnect the White kill wire and connect a jumper wire from the White wire to engine ground. If you still have spark, the power pack is likely bad. If the engine has no spark with the jumper connected, either the wiring harness, keyswitch or emergency stop switch is bad.

## E75 HP (3 Cyl) 1997-2000 688-85540-00-00

### NO SPARK ON ANY CYLINDER:

1. Disconnect the White stop wire and retest. If the engine's ignition now has spark, the stop circuit has a fault. Check the key switch, harness and shift switch.
2. Inspect and clean all engine and ignition ground connections.
3. Check the resistance and DVA output of the Stator and Trigger:

| Read from                | Read to                   | OEM Reading  | CDI Reading  | DVA (connected) |
|--------------------------|---------------------------|--------------|--------------|-----------------|
| White/Red Trigger wire   | White/Yellow Trigger wire | 256-384 ohms | 256-384 ohms | 3 V Minimum     |
| White/Black Trigger wire | White/Green Trigger wire  | 256-384 ohms | 256-384 ohms | 3 V Minimum     |
| Brown Stator wire        | Blue Stator wire          | 428-642 ohms | 600-800 ohms | 105 V Minimum   |
| Red Stator wire          | Blue Stator wire          | 48-72 ohms   | 10-20 ohms   | 45 V Minimum    |

4. Check the cranking RPM. A cranking speed of less than 250-RPM will not allow the system to spark properly. This can be caused by a weak battery, dragging starter, bad battery cables or a mechanical problem inside the engine.

### NO SPARK OR INTERMITTENT SPARK ON ONE OR MORE CYLINDERS:

1. Check the resistance and DVA output of the Stator and Trigger:

| Read from                | Read to                   | OEM Reading      | CDI Reading  | DVA (connected) |
|--------------------------|---------------------------|------------------|--------------|-----------------|
| White/Red Trigger wire   | White/Yellow Trigger wire | 256-384 ohms     | 256-384 ohms | 3 V Minimum     |
| White/Black Trigger wire | White/Green Trigger wire  | 256-384 ohms     | 256-384 ohms | 3 V Minimum     |
| Brown Stator wire        | Blue Stator wire          | 428-642 ohms     | 600-800 ohms | 105 V Minimum   |
| Red Stator wire          | Blue Stator wire          | 48-72 ohms       | 10-20 ohms   | 45 V Minimum    |
| Black/White (All Cyl)    | Engine Ground             | -                |              | 105 V Minimum   |
| Spark plug Lead          | Engine ground             | 3.28K-4.92K ohms |              |                 |

2. Check the DVA output on the Black/White wires from the power pack while connected to the ignition coils. You should have a reading of at least 125V or more. If the reading is low on one cylinder, disconnect the wire from the ignition coil for that cylinder and reconnect it to a load resistor. Retest. If the reading is now good, the ignition coil is likely bad. A continued low reading indicates a bad power pack or trigger (test per above).

## **Yamaha Troubleshooting**

### **ENGINE WILL NOT ACCELERATE ABOVE APPROXIMATELY 2000 RPM:**

1. Verify the engine is not overheating and causing the power pack to limit the RPM.
2. Disconnect the Pink wire from the power pack and retest. If the engine now performs correctly, check the overheat sensor, oil level in the oil tank mounted on the engine and the wiring harness.
3. Check the position of the Pink wire and make sure it is not next to a spark plug wire.

### **ENGINE WILL NOT ACCELERATE ABOVE APPROXIMATELY 2500 RPM:**

1. Using an inductive tachometer, check the RPM on all cylinders. A difference in readings between the individual cylinders can be caused by a bad coil, power pack or spark plug.
2. If all cylinders show the same RPM and the engine will only rev to approximately 2500 RPM, check the running stator DVA output from idle thru WOT. You should show an increase in voltage on the Blue to the Red stator wire throughout the RPM range until it peaks out at approximately 300 Volts. A drop in voltage can be the result of a bad stator coil or a bad regulator/rectifier (disconnect the Green wires to the regulator/rectifier and retest – if the engine now performs OK, the regulator/rectifier is likely bad).

### **MISS AT ANY RPM:**

1. Verify the engine is not overheating and causing the problem.
2. Using an inductive tachometer, check the RPM on all cylinders. A difference in readings between the individual cylinders can be caused by a bad coil, power pack or spark plug.
3. Disconnect the Green wires to the regulator/rectifier and retest – if the engine now performs OK, the regulator/rectifier is likely bad.

### **S.A.F.E. WILL NOT ENGAGE:**

Disconnect the Pink warning wire from the power pack. Connect a jumper wire to engine ground and connect it to the terminal where the Pink wire goes. If the engine now limits at approximately 2000 RPM, check the wiring from the temperature sensor and oil tank to the power pack. If it still fails to engage, the power pack is likely bad.

### **ENGINE WILL NOT STOP:**

Disconnect the White stop wire and connect a jumper wire to engine ground. If you still have spark, the power pack is likely bad. If the engine has no spark with the jumper connected, either the wiring harness, key switch or emergency stop switch is bad.

**Yamaha Troubleshooting**

**C115 (4 Cyl) 1991-1996**  
**115 (4 Cyl) 1984-1989**  
**130 (4 Cyl) 1988-1989**  
**6E5-85540-12-00**

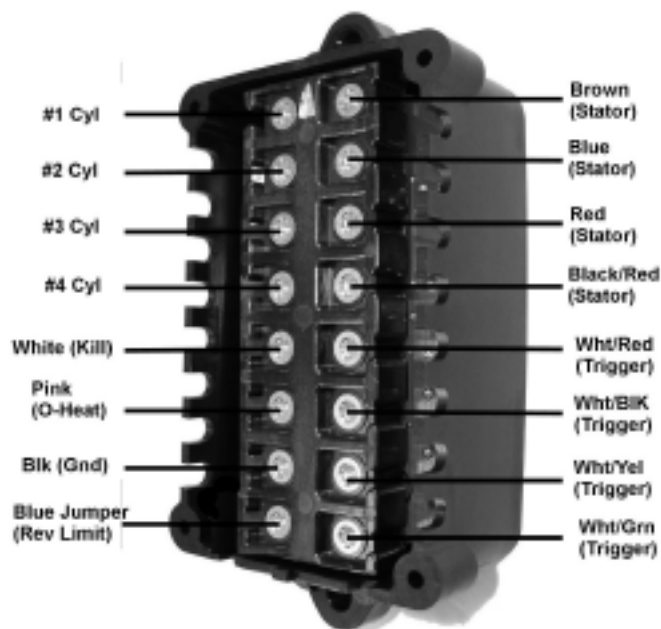

**NO SPARK ON ANY CYLINDER:**

1. Disconnect the White stop wire and retest. If the engine's ignition now has spark, the stop circuit has a fault. Check the key switch, harness and shift switch.
2. Inspect and clean all engine and ignition ground connections.
3. Check the resistance and DVA output of the Stator and Trigger:

| Read from                | Read to                   | OEM Reading   | CDI Reading  | DVA (connected) |
|--------------------------|---------------------------|---------------|--------------|-----------------|
| White/Red Trigger wire   | White/Yellow Trigger wire | 288-432 ohms  | -            | 2.5 V Minimum   |
| White/Black Trigger wire | White/Green Trigger wire  | 288-432 ohms  | -            | 2.5 V Minimum   |
| Brown Stator wire        | Red Stator wire           | 840-1260 ohms | 600-800 ohms | 85 V Minimum    |
| Blue Stator wire         | Black/Red Stator wire     | 102-152 ohms  | 10-20 ohms   | 45 V Minimum    |

4. Disconnect the Blue Jumper wire from terminal 8. If spark returns, replace the power pack.
5. Check the cranking RPM. A cranking speed of less than 250-RPM may not allow the system to spark properly. This can be caused by a weak battery, dragging starter, bad battery cables or a mechanical problem inside the engine.

**NO SPARK OR INTERMITTENT SPARK ON ONE OR MORE CYLINDERS:**

1. Check the resistance and DVA output of the Stator and Trigger:

| Read from                 | Read to                   | OEM Reading   | CDI Reading  | DVA (connected)  |
|---------------------------|---------------------------|---------------|--------------|------------------|
| White/Red Trigger wire    | White/Yellow Trigger wire | 288-432 ohms  | -            | 2.5 V Minimum    |
| White/Black Trigger wire  | White/Green Trigger wire  | 288-432 ohms  | -            | 2.5 V Minimum    |
| White/Red Trigger wire    | Eng Ground                | Open          | Open         | 2.5 V Minimum    |
| White/Black Trigger wire  | Eng Ground                | Open          | Open         | 2.5 V Minimum    |
| White/Yellow Trigger wire | Eng Ground                | Open          | Open         | 2.5 V Minimum    |
| White/Green Trigger wire  | Eng Ground                | Open          | Open         | 2.5 V Minimum    |
| Brown Stator wire         | Red Stator wire           | 840-1260 ohms | 600-800 ohms | 85 Volts Minimum |
| Brown Stator wire         | Eng Ground                | Open          | Open         | 85 Volts Minimum |
| Red Stator wire           | Eng Ground                | Open          | Open         | 85 Volts Minimum |
| Blue Stator wire          | Black/Red Stator wire     | 62-79 ohms    | 10-20 ohms   | 16 Volts Minimum |
| Blue Stator wire          | Eng Ground                | Open          | Open         | 16 Volts Minimum |
| Black/Red Stator wire     | Eng Ground                | Open          | Open         | 16 Volts Minimum |



## **Yamaha Troubleshooting**

2. Disconnect the Blue Jumper wire from terminal 8. If the engine runs normally, replace the power pack.
3. Check the DVA output on the Black/White wires from the power pack while connected to the ignition coils. You should have a reading of at least 85V or more. If the reading is low on one cylinder, disconnect the wire from the ignition coil for that cylinder and reconnect it to a load resistor. Retest. If the reading is now good, the ignition coil is likely bad. A continued low reading indicates a bad power pack or trigger (test per above).

### **ENGINE WILL NOT ACCELERATE ABOVE APPROXIMATELY 2000 RPM:**

1. Verify the engine is not overheating and causing the power pack to limit the RPM.
2. Disconnect the Blue Jumper wire from terminal 8. If the engine runs normally, replace the power pack.
3. Disconnect the Pink wire from the power pack and retest. If the engine now performs correctly, check the overheat sensor, oil level in the oil tank mounted on the engine and the wiring harness.
4. Check the position of the Pink wire and make sure it is not next to a spark plug wire.

### **ENGINE WILL NOT ACCELERATE ABOVE APPROXIMATELY 2500 RPM:**

1. Using an inductive tachometer, check the RPM on all cylinders. A difference in readings between the individual cylinders can be caused by a bad coil, power pack or spark plug.
2. If all cylinders show the same RPM and the engine will only rev to approximately 2500 RPM, check the running stator DVA output from idle thru WOT. You should show a steady increase in voltage on the Blue to the Black/Red stator wires throughout the RPM range. A drop in voltage can be the result of a bad stator coil or a bad regulator/rectifier (disconnect the Green wires to the regulator/rectifier and retest – if the engine now performs OK, the regulator/rectifier is likely bad).
3. Disconnect the Blue Jumper wire from terminal 8. If the engine runs normally, replace the power pack.

### **MISS AT ANY RPM:**

1. Verify the engine is not overheating and causing the problem.
2. Using an inductive tachometer, check the RPM on all cylinders. A difference in readings between the individual cylinders can be caused by a bad coil, power pack or spark plug.
3. Disconnect the Green wires to the regulator/rectifier and retest – if the engine now performs OK, the regulator/rectifier is likely bad.
4. Disconnect the Blue Jumper wire from terminal 8. If the engine runs normally, replace the power pack.

### **S.A.F.E. WILL NOT ENGAGE:**

Disconnect the Pink warning wire from the power pack and connect a jumper wire from the terminal to engine ground. If the engine now limits at approximately 2000 RPM, check the wiring from the temperature sensor and oil tank to the power pack. If it still fails to engage, the power pack is likely bad.

### **ENGINE WILL NOT STOP:**

Disconnect the White stop wire and connect a jumper wire to engine ground. If you still have spark, the power pack is likely bad. If the engine has no spark with the jumper connected, either the wiring harness, keyswitch or emergency stop switch is bad.

## **C115 (4 Cyl) 1997-1999 6E5-85540-00-00**

### **NO SPARK ON ANY CYLINDER:**

1. Disconnect the White stop wire and retest. If the engine's ignition now has spark, the stop circuit has a fault. Check the key switch, harness and shift switch.
2. Inspect and clean all engine and ignition ground connections.
3. Check the resistance and DVA output of the Stator and Trigger:

| Read from                | Read to                   | OEM Reading   | CDI Reading  | DVA (connected) |
|--------------------------|---------------------------|---------------|--------------|-----------------|
| White/Red Trigger wire   | White/Yellow Trigger wire | 288-432 ohms  | -            | 2.5 V Minimum   |
| White/Black Trigger wire | White/Green Trigger wire  | 288-432 ohms  | -            | 2.5 V Minimum   |
| Brown Stator wire        | Red Stator wire           | 840-1260 ohms | 600-800 ohms | 160 V Minimum   |
| Blue Stator wire         | Black/Red Stator wire     | 62-79 ohms    | 10-20 ohms   | 20 V Minimum    |

4. Check the cranking RPM. A cranking speed of less than 250-RPM may not allow the system to spark properly. This can be caused by a weak battery, dragging starter, bad battery cables or a mechanical problem inside the engine.

## Yamaha Troubleshooting

### NO SPARK OR INTERMITTENT SPARK ON ONE OR MORE CYLINDERS:

1. Check the resistance and DVA output of the Stator and Trigger:

| Read from                 | Read to               | OEM Reading   | CDI Reading  | DVA (connected)  |
|---------------------------|-----------------------|---------------|--------------|------------------|
| White/Red Trigger wire    | White/Yellow          | Trigger wire  | 288-432 ohms | 2.5 V Minimum    |
| White/Black Trigger wire  | White/Green           | Trigger wire  | 288-432 ohms | 2.5 V Minimum    |
| White/Red Trigger wire    | Eng Ground            | Open          | Open         | 2.5 V Minimum    |
| White/Black Trigger wire  | Eng Ground            | Open          | Open         | 2.5 V Minimum    |
| White/Yellow Trigger wire | Eng Ground            | Open          | Open         | 2.5 V Minimum    |
| White/Green Trigger wire  | Eng Ground            | Open          | Open         | 2.5 V Minimum    |
| Brown Stator wire         | Red Stator wire       | 840-1260 ohms | 600-800 ohms | 85 Volts Minimum |
| Brown Stator wire         | Eng Ground            | Open          | Open         | 85 Volts Minimum |
| Red Stator wire           | Eng Ground            | Open          | Open         | 85 Volts Minimum |
| Blue Stator wire          | Black/Red Stator wire | 62-79 ohms    | 10-20 ohms   | 20 Volts Minimum |
| Blue Stator wire          | Eng Ground            | Open          | Open         | 20 Volts Minimum |
| Black/Red Stator wire     | Eng Ground            | Open          | Open         | 20 Volts Minimum |

2. Remove the resistive sparkplug caps from the sparkplug leads and check the resistance from the wire pin to the terminal that goes on the sparkplug. You should read between 4 K and 6 K ohms. If the reading is over the 6K ohms specification, replace the sparkplug cap.
3. Check the DVA output on the Black/White wires from the power pack while connected to the ignition coils. You should have a reading of at least 125V or more. If the reading is low on one cylinder, disconnect the wire from the ignition coil for that cylinder and reconnect it to a load resistor. Retest. If the reading is now good, the ignition coil is likely bad. A continued low reading indicates a bad power pack or trigger (test per above).

### ENGINE WILL NOT ACCELERATE ABOVE APPROXIMATELY 2000 RPM:

1. Verify the engine is not overheating and causing the power pack to limit the RPM.
2. Disconnect the Pink wire from the power pack and retest. If the engine now performs correctly, check the overheat sensor, oil level in the oil tank mounted on the engine and the wiring harness.
3. Check the position of the Pink wire and make sure it is not next to a spark plug wire.
4. Remove the resistive sparkplug caps from the sparkplug leads and check the resistance from the wire pin to the terminal that goes on the sparkplug. You should read between 4 K and 6 K ohms. If the reading is over the 6K ohms specification, replace the sparkplug cap.

### ENGINE WILL NOT ACCELERATE ABOVE APPROXIMATELY 2500 RPM:

1. Using an inductive tachometer, check the RPM on all cylinders. A difference in readings between the individual cylinders can be caused by a bad coil, power pack or spark plug.
2. If all cylinders show the same RPM and the engine will only rev to approximately 2500 RPM, check the running stator DVA output from idle thru WOT. You should show a steady increase in voltage on the Blue to the Black/Red stator wires throughout the RPM range. A drop in voltage can be the result of a bad stator coil or a bad regulator/rectifier (disconnect the Green wires to the regulator/rectifier and retest – if the engine now performs OK, the regulator/rectifier is likely bad).
3. Remove the resistive sparkplug caps from the sparkplug leads and check the resistance from the wire pin to the terminal that goes on the sparkplug. You should read between 4 K and 6 K ohms. If the reading is over the 6K ohms specification, replace the sparkplug cap.

### MISS AT ANY RPM:

1. Verify the engine is not overheating and causing the problem.
2. Using an inductive tachometer, check the RPM on all cylinders. A difference in readings between the individual cylinders can be caused by a bad coil, power pack or spark plug.
3. Disconnect the Green wires to the regulator/rectifier and retest – if the engine now performs OK, the regulator/rectifier is likely bad.

### S.A.F.E. WILL NOT ENGAGE:

Disconnect the Pink warning wire from the power pack. Connect a jumper wire to engine ground and connect it to the terminal where the Pink wire goes. If the engine now limits at approximately 2000 RPM, check the wiring from the temperature sensor and oil tank to the power pack. If the SAFE Mode fails to engage, the power pack is likely bad.

## **Yamaha Troubleshooting**

### **ENGINE WILL NOT STOP:**

Disconnect the White stop wire and connect a jumper wire to engine ground. If you still have spark, the power pack is likely bad. If the engine has no spark with the jumper connected, either the wiring harness, keyswitch or emergency stop switch is bad.

**C115 (4 Cyl) 2000**  
**P115 (4 Cyl) 1993-1996**  
**B115 (4 Cyl) 1998-1999**  
**S115 (4 Cyl) 1996-1999**  
**115 (4 Cyl) 1990-2010**  
**130 (4 Cyl) 1990-2004**

### **6N7-85540-01-00**

### **NO SPARK ON ANY CYLINDER:**

1. Disconnect the White stop wire and retest. If the engine's ignition now has spark, the stop circuit has a fault. Check the key switch, harness and shift switch.
2. Inspect and clean all engine and ignition ground connections.
3. Check the resistance and DVA output of the Stator and Trigger:

| Read from                | Read to                   | OEM Reading  | CDI Reading | DVA (connected) |
|--------------------------|---------------------------|--------------|-------------|-----------------|
| White/Red Trigger wire   | White/Yellow Trigger wire | 256-384 ohms | -           | 2.5 V Minimum   |
| White/Black Trigger wire | White/Green Trigger wire  | 256-384 ohms | -           | 2.5 V Minimum   |
| Brown Stator wire        | Red Stator wire           | 592-888 ohms | -           | 160 V Minimum   |
| Blue Stator wire         | Black/Red Stator wire     | 55-83 ohms   | 10-20 ohms  | 45 V Minimum    |

4. Check the cranking RPM. A cranking speed of less than 250-RPM may not allow the system to spark properly. This can be caused by a weak battery, dragging starter, bad battery cables or a mechanical problem inside the engine.

### **NO SPARK OR INTERMITTENT SPARK ON ONE OR MORE CYLINDERS:**

1. Check the resistance and DVA output of the Stator and Trigger:

| Read from                | Read to                   | OEM Reading  | DVA (connected) |
|--------------------------|---------------------------|--------------|-----------------|
| White/Red Trigger wire   | White/Yellow Trigger wire | 256-384 ohms | 2.5 V Minimum   |
| White/Black Trigger wire | White/Green Trigger wire  | 256-384 ohms | 2.5 V Minimum   |
| Brown Stator wire        | Red Stator wire           | 592-888 ohms | 160 V Minimum   |
| Blue Stator wire         | Black/Red Stator wire     | 55-83 ohms   | 45 V Minimum    |
| Black/White Coil Leads   | Engine Ground             |              | 125 V Minimum   |

2. Remove the resistive sparkplug caps from the sparkplug leads and check the resistance of the sparkplug caps from the wire pin to the terminal that goes on the sparkplug. You should read between 4 K and 6 K ohms. If the reading is over the 6K ohms specification, replace the sparkplug cap.
3. Check the resistance of the ignition coil's secondary resistance. You should read between 3.04 K to 4.58 K ohms from the sparkplug lead to the Black ground wire with the resistive sparkplug cap removed.
4. Check the DVA output on the Black/White wires from the power pack while connected to the ignition coils. You should have a reading of at least 125V or more. If the reading is low on one cylinder, disconnect the wire from the ignition coil for that cylinder and reconnect it to a load resistor. Retest. If the reading is now good, the ignition coil is likely bad. A continued low reading indicates a bad power pack or trigger (test per above).

### **ENGINE WILL NOT ACCELERATE ABOVE APPROXIMATELY 2000 RPM:**

1. Verify the engine is not overheating and causing the power pack to limit the RPM.
2. Disconnect the Pink wire from the power pack and retest. If the engine now performs correctly, check the overheat sensor, oil level in the oil tank mounted on the engine and the wiring harness.
3. Check the position of the Pink wire and make sure it is not next to a spark plug wire.
4. Remove the resistive sparkplug caps from the sparkplug leads and check the resistance from the wire pin to the terminal that goes on the sparkplug. You should read between 4 K and 6 K ohms. If the reading is over the 6K ohms specification, replace the sparkplug cap.

## **Yamaha Troubleshooting**

### **ENGINE WILL NOT ACCELERATE ABOVE APPROXIMATELY 2500 RPM:**

1. Using an inductive tachometer, check the RPM on all cylinders. A difference in readings between the individual cylinders can be caused by a bad coil, power pack or spark plug.
2. If all cylinders show the same RPM and the engine will only rev to approximately 2500 RPM, check the running stator DVA output from idle thru WOT. You should show a steady increase in voltage on the Blue to the Black/Red stator wires throughout the RPM range. A drop in voltage can be the result of a bad stator coil or a bad regulator/rectifier (disconnect the Green wires to the regulator/rectifier and retest – if the engine now performs OK, the regulator/rectifier is likely bad).
3. Remove the resistive sparkplug caps from the sparkplug leads and check the resistance from the wire pin to the terminal that goes on the sparkplug. You should read between 4 K and 6 K ohms. If the reading is over the 6K ohms specification, replace the sparkplug cap.

### **MISS AT ANY RPM:**

1. Verify the engine is not overheating and causing the problem.
2. Using an inductive tachometer, check the RPM on all cylinders. A difference in readings between the individual cylinders can be caused by a bad coil, power pack or spark plug.
3. Disconnect the Green wires to the regulator/rectifier and retest – if the engine now performs OK, the regulator/rectifier is likely bad.

### **S.A.F.E. WILL NOT ENGAGE:**

Disconnect the Pink warning wire from the power pack. Connect a jumper wire to engine ground and connect it to the terminal where the Pink wire goes. If the engine now limits at approximately 2000 RPM, check the wiring from the temperature sensor and oil tank to the power pack. If the SAFE Mode fails to engage, the power pack is likely bad.

### **ENGINE WILL NOT STOP:**

Disconnect the White stop wire and connect a jumper wire to engine ground. If you still have spark, the power pack is likely bad. If the engine has no spark with the jumper connected, either the wiring harness, keyswitch or emergency stop switch is bad.

# Yamaha Troubleshooting

150 HP (6 Cyl) 1984-1989  
 P150 HP (6 Cyl) 1986-1989  
 175 HP (6 Cyl) 1984-1989  
 200 HP (6 Cyl) 1984-1989  
 220 HP (6 Cyl) 1984-1986 V-6 Special  
 225 HP (6 Cyl) 1987-1989 Excel  
 6G5-85540-12-00

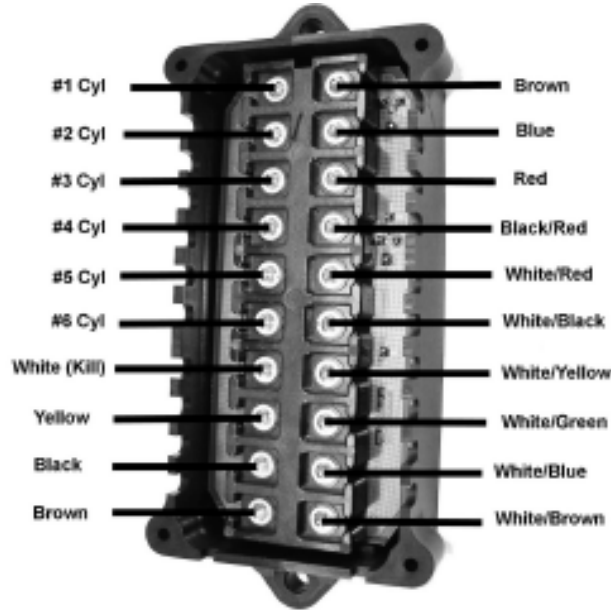

Yamaha

### NO SPARK ON ANY CYLINDER:

1. Disconnect the White stop wire and retest. If the engine's ignition now has spark, the stop circuit has a fault. Check the key switch, harness and shift switch.
2. Inspect and clean all engine and ignition ground connections.
3. Check the resistance and DVA output of the Stator and Trigger:

| Read from                  | Read to                   | OEM Reading   | CDI Reading  | DVA (connected) |
|----------------------------|---------------------------|---------------|--------------|-----------------|
| White/Red Trigger wire     | White/ Green Trigger wire | 288-432 ohms  | -            | 2.5 V Minimum   |
| White/Black Trigger wire   | White/Blue Trigger wire   | 288-432 ohms  | -            | 2.5 V Minimum   |
| White/ Yellow Trigger wire | White/Brown Trigger wire  | 288-432 ohms  | -            | 2.5 V Minimum   |
| Brown Stator wire          | Red Stator wire           | 840-1260 ohms | 600-800 ohms | 85 V Minimum    |
| Blue Stator wire           | Black/Red Stator wire     | 65-130 ohms   | 10-20 ohms   | 25 V Minimum    |

4. Check the cranking RPM. A cranking speed of less than 250-RPM will not allow the system to spark properly. This can be caused by a weak battery, dragging starter, bad battery cables or a mechanical problem inside the engine.

### NO SPARK OR INTERMITTENT SPARK ON ONE OR MORE CYLINDERS:

1. Check the resistance and DVA output of the Stator and Trigger:

| Read from                  | Read to                  | OEM Reading               | CDI Reading  | DVA (connected) |
|----------------------------|--------------------------|---------------------------|--------------|-----------------|
| White/                     | Red Trigger wire         | White/ Green Trigger wire | 288-432 ohms | 2.5 V Minimum   |
| White/Red Trigger wire     | Eng Ground               | Open                      | Open         | 2.5 V Minimum   |
| White/ Green Trigger wire  | Eng Ground               | Open                      | Open         | 2.5 V Minimum   |
| White/Black Trigger wire   | White/Blue Trigger wire  | 288-432 ohms              | -            | 2.5 V Minimum   |
| White/ Black Trigger wire  | Eng Ground               | Open                      | Open         | 2.5 V Minimum   |
| White/ Blue Trigger wire   | Eng Ground               | Open                      | Open         | 2.5 V Minimum   |
| White/ Yellow Trigger wire | White/Brown Trigger wire | 288-432 ohms              | -            | 2.5 V Minimum   |
| White/ Yellow Trigger wire | Eng Ground               | Open                      | Open         | 2.5 V Minimum   |
| White/Brown Trigger wire   | Eng Ground               | Open                      | Open         | 2.5 V Minimum   |
| Brown Stator wire          | Red Stator wire          | 840-1260 ohms             | 600-800 ohms | 85 V Minimum    |
| Brown Stator wire          | Eng Ground               | Open                      | Open         | 85 V Minimum    |
| Red Stator wire            | Eng Ground               | Open                      | Open         | 85 V Minimum    |
| Blue Stator wire           | Black/Red Stator wire    | 65-130 ohms               | 10-20 ohms   | 16 V Minimum    |
| Blue Stator wire           | Eng Ground               | Open                      | Open         | 16 V Minimum    |
| Black/Red Stator wire      | Eng Ground               | Open                      | Open         | 16 V Minimum    |



## **Yamaha Troubleshooting**

2. Check the DVA output on the Black/White wires from the power pack while connected to the ignition coils. You should have a reading of at least 125V or more. If the reading is low on one cylinder, disconnect the wire from the ignition coil for that cylinder and reconnect it to a load resistor. Retest. If the reading is now good, the ignition coil is likely bad. A continued low reading indicates a bad power pack or trigger (test per above).

### **ENGINE WILL NOT ACCELERATE ABOVE APPROXIMATELY 2000 RPM:**

1. Verify the engine is not overheating and causing the control module to limit the RPM.
2. Disconnect the White wire on the power pack coming from the control module and retest. If the engine now performs correctly, check the overheat sensor, oil level in the oil tank mounted on the engine and the wiring harness. If everything tests correctly, the control module is likely defective.

### **ENGINE WILL NOT ACCELERATE ABOVE APPROXIMATELY 2500 RPM:**

1. Using an inductive tachometer, check the RPM on all cylinders. A difference in readings between the individual cylinders can be caused by a bad coil, power pack or spark plug.
2. If all cylinders show the same RPM and the engine will only rev to approximately 2500 RPM, check the running stator DVA output from idle thru WOT. You should show a steady increase in voltage on the Blue to the Black/Red stator wires throughout the RPM range. A drop in voltage can be the result of a bad stator coil or a bad regulator/rectifier (disconnect the Green wires to the regulator/rectifier and retest – if the engine now performs OK, the regulator/rectifier is likely bad).

### **MISS AT ANY RPM:**

1. Verify the engine is not overheating and causing the problem.
2. Using an inductive tachometer, check the RPM on all cylinders. A difference in readings between the individual cylinders can be caused by a bad coil, power pack or spark plug.
3. Disconnect the Green wires to the regulator/rectifier and retest – if the engine now performs OK, the regulator/rectifier is likely bad.

### **S.A.F.E. WILL NOT ENGAGE OR ENGINES REVS ABOVE 6500 RPM:**

1. Disconnect the Pink warning wire from the control module. Connect a jumper wire to engine ground and connect it to the terminal where the Pink wire goes. If the engine now limits at approximately 2000 RPM, check the wiring from the temperature sensor and oil tank to the power pack. If it still fails to engage, the power pack is likely bad.
2. Check the voltage on the Brown wire going to the control module. You should see approximately 35 volts when running at idle. Low or high voltage is likely to be a shorted control module and a very low voltage is likely to be a defective power pack.

### **ENGINE WILL NOT STOP:**

Disconnect the White stop wire and connect a jumper wire to engine ground. If you still have spark, the power pack is likely bad. If the engine has no spark with the jumper connected, either the wiring harness, key switch or emergency stop switch is bad.

**150-200 HP (6 Cyl) 1990-1995**  
**L150-L200 HP (6 Cyl) 1990-1995**  
**P150-P200 HP (6 Cyl) 1990-1995**  
**ProV 150 HP (6 Cyl) 1990-1995**

**61H-85540-00-00/62H-85540-00-00**

### **NO SPARK ON ANY CYLINDER:**

1. Disconnect the White stop wire and retest. If the engine's ignition now has spark, the stop circuit has a fault. Check the key switch, harness and shift switch.
2. Inspect and clean all engine and ignition ground connections.

## Yamaha Troubleshooting

3. Check the resistance and DVA output of the Stator and Trigger:

| Read from                  | Read to                   | OEM Reading  | CDI Reading  | DVA (connected) |
|----------------------------|---------------------------|--------------|--------------|-----------------|
| White/Red Trigger wire     | White/ Green Trigger wire | 256-384 ohms | -            | 2 V Minimum     |
| White/Black Trigger wire   | White/Blue Trigger wire   | 256-384 ohms | -            | 2 V Minimum     |
| White/ Yellow Trigger wire | White/Brown Trigger wire  | 256-384 ohms | -            | 2 V Minimum     |
| Brown Stator wire          | Red Stator wire           | 592-888 ohms | 600-800 ohms | 145 V Minimum   |
| Blue Stator wire           | Black/Red Stator wire     | 55-83 ohms   | 10-20 ohms   | 40 V Minimum    |

4. Check the cranking RPM. A cranking speed of less than 250-RPM will not allow the system to spark properly. This can be caused by a weak battery, dragging starter, bad battery cables or a mechanical problem inside the engine.

### NO SPARK OR INTERMITTENT SPARK ON ONE OR MORE CYLINDERS:

1. Check the resistance and DVA output of the Stator and Trigger:

| Read from                  | Read to                   | OEM Reading   | CDI Reading  | DVA (connected) |
|----------------------------|---------------------------|---------------|--------------|-----------------|
| White/Red Trigger wire     | White/ Green Trigger wire | 256-384 ohms  | -            | 2 V Minimum     |
| White/Red Trigger wire     | Eng Ground                | Open          | Open         | 2.5 V Minimum   |
| White/ Green Trigger wire  | Eng Ground                | Open          | Open         | 2.5 V Minimum   |
| White/Black Trigger wire   | White/Blue Trigger wire   | 288-432 ohms  | -            | 2.5 V Minimum   |
| White/ Black Trigger wire  | Eng Ground                | Open          | Open         | 2.5 V Minimum   |
| White/ Blue Trigger wire   | Eng Ground                | Open          | Open         | 2.5 V Minimum   |
| White/ Yellow Trigger wire | White/Brown Trigger wire  | 288-432 ohms  | -            | 2.5 V Minimum   |
| White/ Yellow Trigger wire | Eng Ground                | Open          | Open         | 2.5 V Minimum   |
| White/Brown Trigger wire   | Eng Ground                | Open          | Open         | 2.5 V Minimum   |
| Brown Stator wire          | Red Stator wire           | 840-1260 ohms | 600-800 ohms | 85 V Minimum    |
| Brown Stator wire          | Eng Ground                | Open          | Open         | 85 V Minimum    |
| Red Stator wire            | Eng Ground                | Open          | Open         | 85 V Minimum    |
| Blue Stator wire           | Black/Red Stator wire     | 65-130 ohms   | 10-20 ohms   | 16 V Minimum    |
| Blue Stator wire           | Eng Ground                | Open          | Open         | 16 V Minimum    |
| Black/Red Stator wire      | Eng Ground                | Open          | Open         | 16 V Minimum    |

2. Check the DVA output on the Black/White wires from the power pack while connected to the ignition coils. You should have a reading of at least 105V or more. If the reading is low on one cylinder, disconnect the wire from the ignition coil for that cylinder and reconnect it to a load resistor. Retest. If the reading is now good, the ignition coil is likely bad. A continued low reading indicates a bad power pack or trigger (test per above).

### ENGINE WILL NOT ACCELERATE ABOVE APPROXIMATELY 2000 RPM:

- Verify the engine is not overheating and causing the control module to limit the RPM.
- Verify the correct sparkplugs are installed and gapped correctly.

### ENGINE WILL NOT ACCELERATE ABOVE APPROXIMATELY 2500 RPM:

- Using an inductive tachometer, check the RPM on all cylinders. A difference in readings between the individual cylinders can be caused by a bad coil, power pack or spark plug.
- If all cylinders show the same RPM and the engine will only rev to approximately 2500 RPM, check the running stator DVA output from idle thru WOT. You should show a steady increase in voltage on the Blue to the Black/Red stator wires throughout the RPM range. A drop in voltage can be the result of a bad stator coil or a bad regulator/rectifier (disconnect the Green wires to the regulator/rectifier and retest – if the engine now performs OK, the regulator/rectifier is likely bad).

### MISS AT ANY RPM:

- Verify the engine is not overheating and causing the problem.
- Using an inductive tachometer, check the RPM on all cylinders. A difference in readings between the individual cylinders can be caused by a bad coil, power pack or spark plug.
- Disconnect the Green wires to the regulator/rectifier and retest – if the engine now performs OK, the regulator/rectifier is likely bad.

### S.A.F.E. WILL NOT ENGAGE OR ENGINES REVS ABOVE 6500 RPM:

- Disconnect the Pink warning wire from the control module. Connect a jumper wire to engine ground and connect it to the terminal where the Pink wire goes. If the engine now limits at approximately 2000 RPM, check the wiring from the temperature sensor and oil tank to the power pack. If it still fails to engage, the power pack is likely bad.
- Check the voltage on the Brown wire going to the control module. You should see approximately 35 volts when running at idle. Low or high voltage is likely to be a shorted control module and a very low voltage is likely to be a defective power pack.

## Yamaha Troubleshooting

### ENGINE WILL NOT STOP:

Disconnect the White stop wire and connect a jumper wire to engine ground. If you still have spark, the power pack is likely bad. If the engine has no spark with the jumper connected, either the wiring harness, key switch or emergency stop switch is bad.

### C150 (6 Cyl) 1996-1999 6G6-85540-00-00

#### NO SPARK ON ANY CYLINDER:

1. Disconnect the White stop wire and retest. If the engine's ignition now has spark, the stop circuit has a fault. Check the key switch, harness and shift switch.
2. Inspect and clean all engine and ignition ground connections.
3. Check the resistance and DVA output of the Stator and Trigger:

| Read from                  | Read to                   | OEM Reading  | CDI Reading | DVA (connected) |
|----------------------------|---------------------------|--------------|-------------|-----------------|
| White/Red Trigger wire     | White/ Green Trigger wire | 256-384 ohms | -           | 2 V Minimum     |
| White/Black Trigger wire   | White/Blue Trigger wire   | 256-384 ohms | -           | 2 V Minimum     |
| White/ Yellow Trigger wire | White/Brown Trigger wire  | 256-384 ohms | -           | 2 V Minimum     |
| Brown Stator wire          | Red Stator wire           | 428-642 ohms | -           | 90 V Minimum    |
| Blue Stator wire           | Black/Red Stator wire     | 64-96 ohms   | -           | 30 V Minimum    |

4. Check the cranking RPM. A cranking speed of less than 250-RPM will not allow the system to spark properly. This can be caused by a weak battery, dragging starter, bad battery cables or a mechanical problem inside the engine.

#### NO SPARK OR INTERMITTENT SPARK ON ONE OR MORE CYLINDERS:

1. Check the resistance and DVA output of the Stator and Trigger:

| Read from                  | Read to                   | OEM Reading  | CDI Reading | DVA (connected) |
|----------------------------|---------------------------|--------------|-------------|-----------------|
| White/Red Trigger wire     | White/ Green Trigger wire | 256-384 ohms | -           | 2 V Minimum     |
| White/Red Trigger wire     | Eng Ground                | Open         | Open        | 2.5 V Minimum   |
| White/ Green Trigger wire  | Eng Ground                | Open         | Open        | 2.5 V Minimum   |
| White/Black Trigger wire   | White/Blue Trigger wire   | 288-432 ohms | -           | 2.5 V Minimum   |
| White/ Black Trigger wire  | Eng Ground                | Open         | Open        | 2.5 V Minimum   |
| White/ Blue Trigger wire   | Eng Ground                | Open         | Open        | 2.5 V Minimum   |
| White/ Yellow Trigger wire | White/Brown Trigger wire  | 288-432 ohms | -           | 2.5 V Minimum   |
| White/ Yellow Trigger wire | Eng Ground                | Open         | Open        | 2.5 V Minimum   |
| White/Brown Trigger wire   | Eng Ground                | Open         | Open        | 2.5 V Minimum   |
| Brown Stator wire          | Red Stator wire           | 428-642 ohms | -           | 90 V Minimum    |
| Brown Stator wire          | Eng Ground                | Open         | Open        | 90 V Minimum    |
| Red Stator wire            | Eng Ground                | Open         | Open        | 90 V Minimum    |
| Blue Stator wire           | Black/Red Stator wire     | 64-96 ohms   | -           | 30 V Minimum    |
| Blue Stator wire           | Eng Ground                | Open         | Open        | 30 V Minimum    |
| Black/Red Stator wire      | Eng Ground                | Open         | Open        | 30 V Minimum    |
| Black/White to Ign Coil    | Eng Ground                |              |             | 65 V Minimum    |

2. Check the DVA output on the Black/White wires from the power pack while connected to the ignition coils. You should have a reading of at least 65V. If the reading is low on one cylinder, disconnect the wire from the ignition coil for that cylinder and reconnect it to a load resistor. Retest. If the reading is now good, the ignition coil is likely bad. A continued low reading indicates a bad power pack or trigger (test per above).

#### ENGINE WILL NOT ACCELERATE ABOVE APPROXIMATELY 2000 RPM:

1. Verify the engine is not overheating and causing the control module to limit the RPM.
2. Verify the correct sparkplugs are installed and gapped correctly.

#### ENGINE WILL NOT ACCELERATE ABOVE APPROXIMATELY 2500 RPM:

1. Using an inductive tachometer, check the RPM on all cylinders. A difference in readings between the individual cylinders can be caused by a bad coil, power pack or spark plug.
2. If all cylinders show the same RPM and the engine will only rev to approximately 2500 RPM, check the running stator DVA output from idle thru WOT. You should show a steady increase in voltage on the Blue to the Black/ Red stator wires throughout the RPM range. A drop in voltage can be the result of a bad stator coil or a bad regulator/rectifier (disconnect the Green wires to the regulator/rectifier and retest – if the engine now performs OK, the regulator/rectifier is likely bad).

## Yamaha Troubleshooting

### MISS AT ANY RPM:

1. Verify the engine is not overheating and causing the problem.
2. Using an inductive tachometer, check the RPM on all cylinders. A difference in readings between the individual cylinders can be caused by a bad coil, power pack or spark plug.
3. Disconnect the Green wires to the regulator/rectifier and retest – if the engine now performs OK, the regulator/rectifier is likely bad.

### S.A.F.E. WILL NOT ENGAGE OR ENGINE REVS ABOVE 6500 RPM:

1. Disconnect the Pink warning wire from the control module. Connect a jumper wire to engine ground and connect it to the terminal where the Pink wire goes. If the engine now limits at approximately 2000 RPM, check the wiring from the temperature sensor and oil tank to the power pack. If it still fails to engage, the power pack is likely bad.
2. Check the voltage on the Brown wire going to the control module. You should see approximately 35 volts when running at idle. Low or high voltage is likely to be a shorted control module and a very low voltage is likely to be a defective power pack.

### ENGINE WILL NOT STOP:

Disconnect the White stop wire and connect a jumper wire to engine ground. If you still have spark, the power pack is likely bad. If the engine has no spark with the jumper connected, either the wiring harness, key switch or emergency stop switch is bad.

Yamaha



## High Performance Spark Plug Wire Set



### FEATURES

- 8mm Wire
- Kevlar Core
- More Spark Energy
- Better EMI Suppression
- Higher Dielectric Strength

**INDEPENDENT TESTING CONFIRMS  
CDI ELECTRONICS HIGH PERFORMANCE  
SPARK PLUG WIRE SET IS SUPERIOR!**

When tested against 7 leading brands, CDI Electronics beat them all!

**More Spark Energy!**

| Brand                       | Spark Energy (mJ)    |
|-----------------------------|----------------------|
| CDI Electronics Kevlar Core | 42 mJ (779 ohms/ft.) |
| Brand A-300                 | 31 mJ (140 ohms/ft.) |
| Brand M1                    | 29 mJ (975 ohms/ft.) |
| Brand J                     | 27 mJ (199 ohms/ft.) |
| Brand T-400                 | 27 mJ (484 ohms/ft.) |
| Brand M2                    | 26 mJ (512 ohms/ft.) |
| Brand A-S-B                 | 22 mJ (503 ohms/ft.) |
| Brand S                     | 22 mJ (247 ohms/ft.) |

SPARK ENERGY - MILLIJOULES (mJ)  
Note: No correlation between Resistance and Spark Energy  
Optimum capacitance, inductance and resistance for maximum energy transmission

| C.C. Marine P/N | CDI Electronics P/N | Malory Marine P/N | Sierra P/N |
|-----------------|---------------------|-------------------|------------|
| 631-00010       | 631-0001            | 9-28012           | 18-8803-2  |
| 631-00040       | 631-0004            | 9-28001           | 18-8804-1  |
| 631-00060       | 631-0006            | 9-28011           | 18-8832-1  |
| 631-00070       | 631-0007            | 9-28020           | 18-8800-1  |
| 631-00080       | 631-0008            | 9-28002           | 18-8804-1  |
| 631-00100       | 631-0010            | 9-28003           | 18-8802-1  |
| 631-00110       | 631-0011            | 9-28009           | 18-8828-1  |
| 631-00120       | 631-0012            | 9-28017           | 18-8809-1  |
| 631-00130       | 631-0013            | 9-28016           | 18-8810-1  |
| 631-00150       | 631-0015            | 9-28014           | 18-8808-2  |
| 631-00170       | 631-0017            | 9-28015           | 18-8801-1  |
| 631-00180       | 631-0018            | 9-28044           | 18-8842-1  |
| 631-00200       | 631-0020            | 9-28031           | 18-8838-1  |
| 631-00210       | 631-0021            | 9-28032           | 18-8801-1  |
| 631-00220       | 631-0022            | 9-28053           |            |
| 631-00230       | 631-0023            | 9-28056           | 18-8833-1  |
| 631-00250       | 631-0025            | 9-28026           | 18-8806-1  |
| 631-00260       | 631-0026            | 9-28030           | 18-8825-1  |

353 James Record Road S.W. Huntsville, AL 35824
1.800.467.3371
CDIElectronics.com

## Yamaha Troubleshooting

**150 HP (6 Cyl) 1996-2009**  
**V150 (6 Cyl) 2000-2009**  
**L150 HP (6 Cyl) 1996-2009**  
**P150 HP (6 Cyl) 1996-2009**  
**S150 HP (6 Cyl) 1996-2009**  
**P175 (6 Cyl) 1996-2009**  
**S175 (6 Cyl) 1996-2009**  
**200 (6 Cyl) 1996-2009**  
**L200 (6 Cyl) 1996-2009**  
**P200 (6 Cyl) 1996-2009**  
**S200 (6 Cyl) 1996-2009**

**64D-85540-01-00/64D-85540-10-00/64E-85540-00-00**

### NO SPARK ON ANY CYLINDER:

1. Disconnect the White stop wire and retest. If the engine's ignition now has spark, the stop circuit has a fault. Check the key switch, harness and shift switch.
2. Inspect and clean all engine and ignition ground connections.
3. Check the resistance and DVA output of the Stator and Trigger:

| Read from                     | Read to                       | OEM Reading  | CDI Reading | DVA (connected) |
|-------------------------------|-------------------------------|--------------|-------------|-----------------|
| White/Red Trigger wire        | White/ Green Trigger wire     | 256-384 ohms | -           | 2 V Minimum     |
| White/ Yellow Trigger wire    | White/Brown Trigger wire      | 256-384 ohms | -           | 2 V Minimum     |
| Brown Stator wire             | Red Stator wire               | 592-888 ohms | -           | 145 V Minimum   |
| Blue Stator wire              | Black/Red Stator wire         | 55-88 ohms   | -           | 40 V Minimum    |
| Green (Crank Position Sensor) | Green (Crank Position Sensor) | 158-255 ohms |             | 2 V Minimum     |

4. Check the cranking RPM. A cranking speed of less than 250-RPM may not allow the system to spark properly. This can be caused by a weak battery, dragging starter, bad battery cables or a mechanical problem inside the engine.

### NO SPARK OR INTERMITTENT SPARK ON ONE OR MORE CYLINDERS:

NOTE: Cylinders 2 & 5 are fired by the CDI Unit Assembly. A sensor problem can cause these cylinders not to fire. All cylinders should have spark over 1800 RPM IN GEAR.

1. Check the resistance and DVA output of the Stator, Trigger and CD Unit:

| Read from                  | Read to                   | OEM Reading  | CDI Reading | DVA (connected) |
|----------------------------|---------------------------|--------------|-------------|-----------------|
| White/Red Trigger wire     | White/ Green Trigger wire | 256-384 ohms | -           | 2 V Minimum     |
| White/ Yellow Trigger wire | White/Brown Trigger wire  | 256-384 ohms | -           | 2 V Minimum     |
| Brown Stator wire          | Red Stator wire           | 592-888 ohms | -           | 140 V Minimum   |
| Blue Stator wire           | Black/Red Stator wire     | 55-88 ohms   | -           | 55 V Minimum    |
| Black/White                | Black                     | -            | -           | 130 V Minimum   |
| Green/White                | Green/Blue                | 179-242 ohms |             | 2 V Minimum     |

2. Check the DVA output on the Black/White wires from the power pack while connected to the ignition coils. You should have a reading of at least 130 V or more. If the reading is low on one cylinder, disconnect the wire from the ignition coil for that cylinder and reconnect it to a load resistor. Retest. If the reading is now good, the ignition coil is likely bad. A continued low reading indicates a bad power pack or trigger (test per above).
3. Check the ignition coil resistance and the spark plug cap. With the spark plug cap removed from the coil, you should read between 4 and 6 K ohms through the cap. The ignition coil should read between 3.78K to 4.92K ohms from the high tension lead to the primary Black lead.

### ENGINE WILL NOT ACCELERATE ABOVE APPROXIMATELY 2000 RPM:

1. Verify the engine is not overheating and causing the control module to limit the RPM.
2. Verify the correct sparkplugs are installed and gapped correctly.



## **Yamaha Troubleshooting**

### **ENGINE WILL NOT ACCELERATE ABOVE APPROXIMATELY 2500 RPM:**

1. Using an inductive tachometer, check the RPM on all cylinders. A difference in readings between the individual cylinders can be caused by a bad coil, power pack or spark plug.
2. If all cylinders show the same RPM and the engine will only rev to approximately 2500 RPM, check the running stator DVA output from idle thru WOT. You should show a steady increase in voltage on the Blue to the Black/Red stator wires throughout the RPM range. A drop in voltage can be the result of a bad stator coil or a bad regulator/rectifier (disconnect the Green wires to the regulator/rectifier and retest – if the engine now performs OK, the regulator/rectifier is likely bad).

### **MISS AT ANY RPM:**

1. Verify the engine is not overheating and causing the problem.
2. Using an inductive tachometer, check the RPM on all cylinders. A difference in readings between the individual cylinders can be caused by a bad coil, power pack or spark plug.
3. Disconnect the Green wires to the regulator/rectifier and retest – if the engine now performs OK, the regulator/rectifier is likely bad.

### **S.A.F.E. WILL NOT ENGAGE OR ENGINES REVS ABOVE 6500 RPM:**

1. Disconnect the Pink warning wire from the control module. Connect a jumper wire to engine ground and connect it to the terminal where the Pink wire goes. If the engine now limits at approximately 2000 RPM, check the wiring from the temperature sensor and oil tank to the power pack. If it still fails to engage, the power pack is likely bad.
2. Check the voltage on the Brown wire going to the control module. You should see approximately 35 volts when running at idle. Low or high voltage is likely to be a shorted control module and a very low voltage is likely to be a defective power pack.

### **ENGINE WILL NOT STOP:**

Disconnect the White stop wire and connect a jumper wire to engine ground. If you still have spark, the power pack is likely bad. If the engine has no spark with the jumper connected, either the wiring harness, key switch or emergency stop switch is bad.

## Yamaha Troubleshooting

**DX150 (6 Cyl) 1999-2005**  
**LX150 (6 Cyl) 1999-2001**  
**PX150 (6Cyl) 1999**  
**SX150 (6Cyl) 1999-2004**  
**VX150 (6 Cyl) 2000-2004**  
**LX200 (6 Cyl) 1999-2001**  
**SX200 (6Cyl) 1999-2004**

**67M-85540-01-00**

### NO SPARK ON ANY CYLINDER:

1. Disconnect the White stop wire and retest. If the engine's ignition now has spark, the stop circuit has a fault. Check the key switch, harness and shift switch.
2. Inspect and clean all engine and ignition ground connections.
3. Check the resistance and DVA output of the Stator and Trigger:

| Read from                  | Read to               | OEM Reading  |   | DVA (connected) |
|----------------------------|-----------------------|--------------|---|-----------------|
| White/Red Trigger wire     | Black                 | 294-398 ohms | - | 3 V Minimum     |
| White/ Yellow Trigger wire | Black                 | 294-398 ohms | - | 3 V Minimum     |
| White/ Green Trigger wire  | Black                 | 294-398 ohms | - | 3 V Minimum     |
| White/ Black Trigger wire  | Black                 | 294-398 ohms | - | 3 V Minimum     |
| White/ Blue Trigger wire   | Black                 | 294-398 ohms | - | 3 V Minimum     |
| White/Brown Trigger wire   | Black                 | 294-398 ohms | - | 3 V Minimum     |
| Brown Stator wire          | Red Stator wire       | 224-336 ohms | - | 115 V Minimum   |
| Blue Stator wire           | Black/Red Stator wire | 224-336 ohms | - | 115 V Minimum   |
| Green/White CPS            | Green/Blue CPS        | 158-255 ohms |   | 0.5 V Minimum   |

4. Check the cranking RPM. A cranking speed of less than 250-RPM may not allow the system to spark properly. This can be caused by a weak battery, dragging starter, bad battery cables or a mechanical problem inside the engine.

### NO SPARK OR INTERMITTENT SPARK ON ONE OR MORE CYLINDERS:

1. Check the resistance and DVA output of the Stator and Trigger:

| Read from                  | Read to               | OEM Reading  | CDI Reading | DVA (connected) |
|----------------------------|-----------------------|--------------|-------------|-----------------|
| White/Red Trigger wire     | Black                 | 294-398 ohms | -           | 3 V Minimum     |
| White/ Yellow Trigger wire | Black                 | 294-398 ohms | -           | 3 V Minimum     |
| White/ Green Trigger wire  | Black                 | 294-398 ohms | -           | 3 V Minimum     |
| White/ Black Trigger wire  | Black                 | 294-398 ohms | -           | 3 V Minimum     |
| White/ Blue Trigger wire   | Black                 | 294-398 ohms | -           | 3 V Minimum     |
| White/Brown Trigger wire   | Black                 | 294-398 ohms | -           | 3 V Minimum     |
| Brown Stator wire          | Red Stator wire       | 224-336 ohms | -           | 115 V Minimum   |
| Blue Stator wire           | Black/Red Stator wire | 224-336 ohms | -           | 115 V Minimum   |

2. Check the DVA output on the Black Striped wires from the power pack while connected to the ignition coils. You should have a reading of at least 100 V or more. If the reading is low on one cylinder, swap the ignition coil with another cylinder and retest. If the problem moves, the ignition coil is likely bad.

### ENGINE WILL NOT ACCELERATE ABOVE APPROXIMATELY 2000 RPM:

1. Verify the engine is not overheating and causing the control module to limit the RPM.
2. Verify the correct sparkplugs are installed and gapped correctly.

### ENGINE WILL NOT ACCELERATE ABOVE APPROXIMATELY 2500 RPM:

1. Using an inductive tachometer, check the RPM on all cylinders. A difference in readings between the individual cylinders can be caused by a bad coil, power pack or spark plug.
2. If all cylinders show the same RPM and the engine will only rev to approximately 2500 RPM, check the running stator DVA output from idle thru WOT. You should show a steady increase in voltage on the Blue to the Black/ Red stator wires throughout the RPM range. A drop in voltage can be the result of a bad stator coil or a bad regulator/rectifier (disconnect the Green wires to the regulator/rectifier and retest – if the engine now performs OK, the regulator/rectifier is likely bad).

## **Yamaha Troubleshooting**

### **MISS AT ANY RPM:**

1. Verify the engine is not overheating and causing the problem.
2. Using an inductive tachometer, check the RPM on all cylinders. A difference in readings between the individual cylinders can be caused by a bad coil, power pack or spark plug.
3. Disconnect the Green wires to the regulator/rectifier and retest – if the engine now performs OK, the regulator/rectifier is likely bad.
4. Check the O2 sensor, White to White should read 100 ohms. Output should vary with throttle movement on a running engine.

### **S.A.F.E. WILL NOT ENGAGE OR ENGINES REVS ABOVE 6500 RPM:**

1. Disconnect the Pink warning wire from the control module. Connect a jumper wire to engine ground and connect it to the terminal where the Pink wire goes. If the engine now limits at approximately 2000 RPM, check the wiring from the temperature sensor and oil tank to the power pack. If it still fails to engage, the power pack is likely bad.
2. Verify the correct spark plugs are installed (incorrect spark plugs can generate RF noise, impacting the circuits inside the engine control module).

### **ENGINE WILL NOT STOP:**

Disconnect the White stop wire and connect a jumper wire to engine ground. If you still have spark, the power pack is likely defective. If the engine has no spark with the jumper connected, check the wiring harness, key switch and emergency stop switch.

**V/VX200 1999-2004**  
**S/X/U/L/LX225 1998-2002**  
**VX225 1998-2004**  
**L/S250 2000-2003**

### **NO SPARK ON ANY CYLINDER:**

1. Disconnect the White stop wire and retest. If the engine's ignition now has spark, the stop circuit has a fault. Check the key switch, harness and shift switch.
2. Inspect and clean all engine and ignition ground connections.
3. Check the resistance and DVA output of the Stator and Trigger:

| Read from                  | Read to               | OEM Reading  |   | DVA (connected) |
|----------------------------|-----------------------|--------------|---|-----------------|
| White/Red Trigger wire     | Black                 | 294-398 ohms | - | 3 V Minimum     |
| White/ Yellow Trigger wire | Black                 | 294-398 ohms | - | 3 V Minimum     |
| White/ Green Trigger wire  | Black                 | 294-398 ohms | - | 3 V Minimum     |
| White/ Black Trigger wire  | Black                 | 294-398 ohms | - | 3 V Minimum     |
| White/ Blue Trigger wire   | Black                 | 294-398 ohms | - | 3 V Minimum     |
| White/Brown Trigger wire   | Black                 | 294-398 ohms | - | 3 V Minimum     |
| Brown Stator wire          | Red Stator wire       | 224-336 ohms | - | 115 V Minimum   |
| Blue Stator wire           | Black/Red Stator wire | 224-336 ohms | - | 115 V Minimum   |
| Green/White CPS            | Green/Blue CPS        | 179-242 ohms |   | 0.5 V Minimum   |

4. Check the cranking RPM. A cranking speed of less than 250-RPM may not allow the system to spark properly. This can be caused by a weak battery, dragging starter, bad battery cables or a mechanical problem inside the engine.

### **NO SPARK OR INTERMITTENT SPARK ON ONE OR MORE CYLINDERS:**

1. Check the resistance and DVA output of the Stator and Trigger:

| Read from                  | Read to               | OEM Reading  | CDI Reading | DVA (connected) |
|----------------------------|-----------------------|--------------|-------------|-----------------|
| White/Red Trigger wire     | Black                 | 294-398 ohms | -           | 3 V Minimum     |
| White/ Yellow Trigger wire | Black                 | 294-398 ohms | -           | 3 V Minimum     |
| White/ Green Trigger wire  | Black                 | 294-398 ohms | -           | 3 V Minimum     |
| White/ Black Trigger wire  | Black                 | 294-398 ohms | -           | 3 V Minimum     |
| White/ Blue Trigger wire   | Black                 | 294-398 ohms | -           | 3 V Minimum     |
| White/Brown Trigger wire   | Black                 | 294-398 ohms | -           | 3 V Minimum     |
| Brown Stator wire          | Red Stator wire       | 224-336 ohms | -           | 115 V Minimum   |
| Blue Stator wire           | Black/Red Stator wire | 224-336 ohms | -           | 115 V Minimum   |

## **Yamaha Troubleshooting**

2. Check the DVA output on the Black Striped wires from the power pack while connected to the ignition coils. You should have a reading of at least 100 V or more. If the reading is low on one cylinder, disconnect the CDI wire from the ignition coil for that cylinder and reconnect it to a load resistor. Retest. If the reading is now good, the ignition coil is likely bad. A continued low reading indicates a bad power pack or trigger (test per above).

### **ENGINE WILL NOT ACCELERATE ABOVE APPROXIMATELY 2000 RPM:**

1. Verify the engine is not overheating and causing the control module to limit the RPM.
2. Verify the correct sparkplugs are installed and gapped correctly.

### **ENGINE WILL NOT ACCELERATE ABOVE APPROXIMATELY 2500 RPM:**

1. Using an inductive tachometer, check the RPM on all cylinders. A difference in readings between the individual cylinders can be caused by a bad coil, power pack or spark plug.
2. If all cylinders show the same RPM and the engine will only rev to approximately 2500 RPM, check the running stator DVA output from idle thru WOT. You should show a steady increase in voltage on the Blue to the Black/Red stator wires throughout the RPM range. A drop in voltage can be the result of a bad stator coil or a bad regulator/rectifier (disconnect the Green wires to the regulator/rectifier and retest – if the engine now performs OK, the regulator/rectifier is likely bad).

### **MISS AT ANY RPM:**

1. Verify the engine is not overheating and causing the problem.
2. Using an inductive tachometer, check the RPM on all cylinders. A difference in readings between the individual cylinders can be caused by a bad coil, power pack or spark plug.
3. Disconnect the Green wires to the regulator/rectifier and retest – if the engine now performs OK, the regulator/rectifier is likely bad.
4. Check the O2 sensor, White to White should read 100 ohms. Output should vary with throttle movement on a running engine.

### **S.A.F.E. WILL NOT ENGAGE OR ENGINES REVS ABOVE 6500 RPM:**

1. Disconnect the Pink warning wire from the control module. Connect a jumper wire to engine ground and connect it to the terminal where the Pink wire goes. If the engine now limits at approximately 2000 RPM, check the wiring from the temperature sensor and oil tank to the power pack. If it still fails to engage, the power pack is likely bad.
2. Verify the correct spark plugs are installed (incorrect spark plugs can generate RF noise, impacting the circuits in side the engine control module).

### **ENGINE WILL NOT STOP:**

Disconnect the White stop wire and connect a jumper wire to engine ground. If you still have spark, the power pack is likely defective. If the engine has no spark with the jumper connected, check the wiring harness, key switch and emergency stop switch.

**Mercury**  
**4 Stroke Ignitions**  
**1 Cylinder Engines 2000-2005**  
**0R036272 & UP with PACK # 803558T02 (3R1060601M/CU2688)**

**4/5/6 HP A Series By Tohatsu**

**NO SPARK:**

1. Disconnect the Brown kill wire. If fire returns, the kill circuit is shorted. Possibly the Stop switch or harness.
2. Verify the correct sparks plugs are installed. OEM recommends NGK DCPR6E, gapped at 0.035 in.
3. Check the stator resistance and DVA output as given below:

| WIRE                        | READ TO                  | OHM RESISTANCE           | DVA (Connected) |
|-----------------------------|--------------------------|--------------------------|-----------------|
| Black/Red (Chg Coil)        | White                    | 95-134                   | 110 V- or more  |
| Red/Wht                     | Black                    | 149-243                  | 2 V or more     |
| Brown (Kill Circuit)        | Black                    | --                       | 10 V or more    |
| Black/Yellow                | Black                    | 0.16-0.24                | 90 V or more    |
| High Tension Lead #1        | Coil Core                | 3.0 -4.4K (Without boot) | --              |
| Sparkplug Boot to sparkplug | Sparkplug Boot Wire Side | 3.5-5.2K                 |                 |

**ENGINE WILL NOT STOP RUNNING:**

Disconnect the Brown kill wire and short it to engine ground. If it stops running, replace the kill switch. If it continues to run, replace the ignition pack.

**HIGH SPEED MISS:**

1. Disconnect the Brown kill wire. If the miss is gone, replace the kill switch.
2. Verify the correct sparks plugs are installed. OEM recommends NGK DCPR6E, gapped at 0.035 in.
3. Check the stator resistance and DVA output as given below. If the voltage drops suddenly right before the miss becomes apparent, the charge coil may be breaking down.

| WIRE                        | READ TO                  | OHM RESISTANCE           | DVA (Connected) |
|-----------------------------|--------------------------|--------------------------|-----------------|
| Black/Red (Chg Coil)        | White                    | 95-134                   | 110 V- or more  |
| Red/Wht                     | Black                    | 149-243                  | 2 V or more     |
| Brown (Kill Circuit)        | Black                    | --                       | 110 V or more   |
| Black/Yellow                | Black                    | 0.16-0.24                | 90 V or more    |
| High Tension Lead #1        | Coil Core                | 3.0 -4.4K (Without boot) | --              |
| Sparkplug Boot to sparkplug | Sparkplug Boot Wire Side | 3.5-5.2K                 |                 |

**Mercury**  
**4 Stroke Ignitions**  
**1 Cylinder Engine 2006-UP with IGNITOR # 339-803559T07 (3AS060410M)**

**4/5/6 HP B Series By Tohatsu**

**NO SPARK:**

1. Disconnect the Brown kill wire. If fire returns, the kill circuit is shorted. Possibly the Stop switch or harness.
2. Verify the correct sparks plugs are installed. OEM recommends NGK DCPR6E, gapped at 0.035 in.
3. Check the stator resistance and DVA output as given below:

| WIRE                        | READ TO                  | OHM RESISTANCE          | DVA (Connected) |
|-----------------------------|--------------------------|-------------------------|-----------------|
| Black/Red (Chg Coil)        | White                    | 95-134                  | 110 V- or more  |
| Red/Wht                     | Black                    | 49-243                  | 2 V or more     |
| Brown (Kill Circuit)        | Black                    | --                      | 110 V or more   |
| Black/Yellow                | Black                    | 0.16-0.24               | 90 V or more    |
| High Tension Lead #1        | Coil Core                | .0 -4.4K (Without boot) | --              |
| Sparkplug Boot to sparkplug | Sparkplug Boot Wire Side | 3.5-5.2K                |                 |

**ENGINE WILL NOT STOP RUNNING:**

Disconnect the Brown kill wire and short it to engine ground. If it stops running, replace the kill switch. If it continues to run, replace the ignition pack.

**Four Stroke**



**Mercury****4 Stroke Ignitions****2 Cylinder Engines 1997-2002****0G760300-0R042474 with PACK # 825667 (6G9-85540-21-00) 117-6921****8/9.9 HP Bondersee by Yamaha****NO SPARK ON ONE CYLINDER:**

Replace the ignition coil.

**NO SPARK ON BOTH CYLINDERS:****WARNING: BOTH SPARKPLUG LEADS MUST BE CONNECTED TO A SPARK TESTER OR THE IGNITION COIL IS VERY LIKELY TO BE DAMAGED.**

1. Disconnect the kill wire (White on pack – Black/Yellow in harness). If fire returns, the kill circuit is shorted. Possibly the Stop switch or harness.
2. Verify the correct spark plugs are installed. OEM recommends NGK DPR6EA-9, gapped at 0.035 in.
3. Check the stator resistance and DVA output as given below:

| WIRE                         | READ TO      | OHMS      | DVA (Minimum Connected)           |
|------------------------------|--------------|-----------|-----------------------------------|
| Brown (Chg Coil)             | Blue         | 280-420   | 90 V + at Idle, 205 V at 1500 RPM |
| Green/Wht or White/Red (CPS) | Black        | 230-350   | 2.5 V + at idle, 7.5V @ 1500 RPM  |
| Orange                       | Black        | 0.16-0.24 | 85 V + at Idle, 195 V at 1500 RPM |
| High Tension Lead #1         |              |           |                                   |
| High Tension Lead #2         | 3.9-5.9K w/o | --        |                                   |

**ENGINE WILL NOT ACCELERATE ABOVE APPROXIMATELY 2000 RPM:**

1. Verify the engine is not overheating and causing the power pack to limit the RPM.
2. Disconnect the Pink wire from the power pack and retest (Note: Some engines may have the Pink wire from the pack connected to a Brown/White wire in the harness). If the engine now performs correctly, check the overheat sensor, oil level in the engine, oil pressure and the wiring harness.
3. Check the position of the Pink wire and make sure it is not next to a spark plug wire.
4. Check ignition timing, it should be between approximately 5 degrees at idle to 30 degrees BTDC at about 3000. If the timing does not advance with RPM, replace the ignition pack.

**ENGINE WILL NOT STOP RUNNING:**

Disconnect the Brown kill wire and short it to engine ground. If it stops running, replace the kill switch. If it continues to run, replace the ignition pack.

**NO WARNING LAMP:**

1. Short the Pink wire from the warning lamp to engine ground and crank the engine over. The lamp should light up.
2. If the warning lamp lights up, check the oil pressure switch. It should be shorted below 2.5 PSI and open above that.
3. If the lamp does not light up with the Pink wire shorted to ground, check the voltage on the Yellow/Red wire going to it. It should be over 3 volts. If the voltage is OK, replace the warning lamp.

**WARNING LAMP DOES NOT GO OFF:**

1. Check the engine oil level.
2. If the warning lamp does not go off, check the oil pressure switch. It should be shorted below 2.5 PSI and open above that

**Mercury****4 Stroke Ignitions****Two Cylinder Engines 2000-2005****8, 9.9, 13.5, 15 HP by Yamaha****835401T 1 (66M-85540-01-00)****NO SPARK ON ONE CYLINDER:**

Replace the ignition coil.

**NO SPARK ON BOTH CYLINDERS:**

1. Disconnect the kill wire (White on pack – Black/Yellow in harness). If fire returns, the kill circuit is shorted. Possibly the Stop switch or harness.
2. Verify the correct sparks plugs are installed. OEM recommends NGK DPR6EA-9, gapped at 0.035 in.
3. Check the stator resistance and DVA output as given below:

| WIRE                              | READ TO              | OEM RESISTANCE         | DVA (Connected) |
|-----------------------------------|----------------------|------------------------|-----------------|
| Brown (Chg Coil)                  | Blue                 | 270-410                | 150 V-325V      |
| Green/Wht (Crank Position Sensor) | Black                | 230-350                | 2.5 V or more   |
| Orange                            | Black                | 0.16-0.24              | 150 V or more   |
| High Tension Lead #1              | High Tension Lead #2 | 3.9-5.9K without boots |                 |

**ENGINE WILL NOT ACCELERATE ABOVE APPROXIMATELY 3000 RPM:**

1. Verify the engine is not overheating and causing the power pack to limit the RPM.
2. Disconnect the Pink wire from the power pack and retest (Note: Some engines may have the Pink wire from the pack connected to a Brown/White wire in the harness). If the engine now performs correctly, check the overheat sensor, oil level in the oil tank mounted on the engine and the wiring harness.
3. Check the position of the Pink wire and make sure it is not next to a spark plug wire.
4. Check ignition timing, it should be between approximately 5 degrees at idle to 30 degrees BTDC at about 3000. If the timing does not advance with RPM, replace the ignition pack.

**NO WARNING LAMP:**

1. Short the Pink wire from the warning lamp to engine ground and crank the engine over. The lamp should light up.
2. If the warning lamp lights up, check the oil pressure switch. It should be shorted below 2.5 PSI and open above that.
3. If the lamp does not light up with the Pink wire shorted to ground, check the voltage on the Yellow/Red wire going to it. It should be over 3 volts. If the voltage is OK, replace the warning lamp.

**WARNING LAMP DOES NOT GO OFF:**

If the warning lamp does not go off, check the oil pressure switch. It should be shorted below 2.5 PSI and open above that.

**Mercury  
4 Stroke Ignitions  
Two Cylinder Engines 2005-2012  
8-9.9 HP by Tohatsu  
835401T02 (3AA060600M)**

**NO SPARK ON ONE CYLINDER:**

Replace the ignition coil.

**NO SPARK ON BOTH CYLINDERS:**

1. Disconnect the kill wire (Brown on pack – may be Black/Yellow in harness). If fire returns, the kill circuit is shorted. Possibly the Stop switch or harness.
2. Verify the correct sparks plugs are installed. OEM recommends NGK DPR6EA-9, gapped at 0.035 in.

3. Check the stator resistance and DVA output as given below:

| WIRE                 | READ TO              | OEM RESISTANCE | DVA (Connected) |
|----------------------|----------------------|----------------|-----------------|
| Black/Red (Chg Coil) | Blue                 | 236-354        | 110 V or more   |
| Red/Wht (Trigger)    | Black                | 148-222        | 2 V or more     |
| Orange               | Black                | 0.248-0.372    | 90 V or more    |
| High Tension Lead #1 | High Tension Lead #2 | 6.8-10.2K      |                 |

**ENGINE WILL NOT ACCELERATE ABOVE APPROXIMATELY 3000 RPM:**

1. Verify the engine is not overheating and causing the power pack to limit the RPM.
2. Disconnect the Light Green Overheat wire from the power pack and retest. If the engine now performs correctly, check the overheat sensor

**Four Stroke**

- If the engine still has a problem, disconnect Brown/White wire. If the engine now performs correctly, check the oil pressure switch and the wiring harness. The oil switch should open contact over 3 PSI.
- Check ignition timing, it should be between approximately 5 degrees at idle to 30 degrees BTDC at about 3000. If the timing does not advance with RPM, replace the ignition pack.
- Check the stator resistance and DVA output as given below:

| WIRE                 | READ TO              | OEM RESISTANCE | DVA (Connected) |
|----------------------|----------------------|----------------|-----------------|
| Black/Red (Chg Coil) | Blue                 | 236-354        | 110 V or more   |
| Red/Wht (Trigger)    | Black                | 148-222        | 2 V or more     |
| Orange               | Black                | 0.248-0.372    | 90 V or more    |
| High Tension Lead #1 | High Tension Lead #2 | 6.8-10.2K      | --              |

#### ENGINE WILL NOT STOP RUNNING:

Disconnect the Brown kill wire and short it to engine ground. If it stops running, replace the kill switch. If it continues to run, replace the ignition pack.

### Mercury 4 Stroke Ignitions Two Cylinder Engines 1998-2006 F25 1998-2005/T25 2001-2006 878433A 1 (65W-85540-00-00)

**Service Notes: Please use the Factory recommended spark plug (currently NGK DPR6EA-9) gapped at 0.035".**

**NOTE: Oil Pressure Light Triggers When Oil Pressure Falls Below 2.13 PSI.**

#### NO SPARK OR WEAK SPARK:

- Disconnect the White stop wire from the Ignition Module. Retest. If the engine's ignition now has spark, the stop circuit has a fault.

- Check the Stator, Trigger and ignition coil as follows:

| Check From:        | Check To:          | Ohms Reading:                | DVA Reading Connected | Disconnected  |
|--------------------|--------------------|------------------------------|-----------------------|---------------|
| Red                | White              | 260 to 390                   | 6 V minimum           | 6 V minimum   |
| Green/White        | Green/White        | 660 to 710                   | 190 V minimum         | 190 V minimum |
| Yellow/Black       | Yellow/Black       | 6.5 to 7.3                   | 7 V minimum           | 10 V minimum  |
| Orange             | Black              |                              | 100 V minimum         |               |
| Spark Plug wire #1 | Spark Plug wire #2 | 3.28K (3280) to 4.92K (4920) |                       |               |

- Check the resistance of the ignition coil between the secondary (spark plug wire) and Black wires, you should read 3.28K (3280) to 4.92K (4920) ohms.

**NO SPARK ON ONE CYLINDER:** Replace the ignition coil.

#### ENGINE WILL NOT ACCELERATE ABOVE APPROXIMATELY 2000 RPM:

- Verify the engine is not overheating and causing the power pack to limit the RPM.
- Verify the oil pressure is over the minimum 2.13 PSI.
- Disconnect the Pink wire from the power pack and retest. If the engine now performs correctly, check the overheat sensor and oil pressure sensor mounted on the engine.
- Check the position of the Pink wire and make sure it is not next to a spark plug wire.
- Check ignition timing, it should be between approximately 4.5-10.5 degrees BTDC at idle to 27-33 degrees BTDC at about 3000. If the timing does not advance with RPM, replace the ignition pack.

#### HAS SPARK BUT WILL NOT RUN:

- Verify the sparkplug gap. The specifications may have changed. Gap should be 0.024-0.028.
- Make sure the throttle plates are closed (the engine will not start if the warm-up lever is raised).
- Make sure the engine is getting fuel to the combustion chamber (make sure there is no water or residue in the carburetor).
- Check flywheel shear key to make sure it has not sheared due to backfiring or impact on the propeller.
- Check flywheel magnet to make sure it has broken loose and moved, causing a timing shift.
- Check spark plug for presence of water, indicating a possible cracked block or blown head gasket.
- Check compression, carburetor, reeds and do a cylinder leak down test.
- Check the fuel in the carburetor. Check to see if a very high ethanol content is present. . If so, purge the fuel

system with fresh fuel and see if the engine will start.

- Check the fuel pressure AT THE CARBURETOR. You should see over 2 PSI. Check fuel lines for inner wall breakdown and wall collapse.
- Check the Triggers as follows as a defective trigger can cause timing variance:

| Check From: | Check To: | Ohms Reading: | DVA Reading Connected | Disconnected |
|-------------|-----------|---------------|-----------------------|--------------|
| Red         | White     | 260 to 390    | 6 V minimum           | 6 V minimum  |

**WILL NOT STOP (KILL):**

- Disconnect the White wire from the CD Module.
- Short the White wire from the CD Module to engine ground. If the engine stops, the problem is in the stop circuit. If the engine continues to run with the White wire shorted to engine ground, replace the defective CD Module.

**WILL NOT CHARGE BATTERY:**

- Check the resistance of the stator yellow wires as follows:

| Check From | Check To      | Ohms Reading | DVA Reading Connected | Disconnected |
|------------|---------------|--------------|-----------------------|--------------|
| Yellow     | Yellow        | 0.22 to 0.24 | 8 V minimum           | 8 V minimum  |
| Yellow     | Engine Ground | Open         | -                     | 1 V or less  |

- Check the charging system output by connecting an inline ammeter between the regulator/rectifier and the positive battery post on the starter solenoid. Connect a battery tester to the battery and start the engine. Increase the engine RPM to approximately 1500-2000 RPM and press the test button on the battery tester. The ammeter should show at least 3 amps of current flow. If not and the stator passes the test above, replace the regulator/rectifier. If the ammeter shows a charge, replace the battery. NOTE: If the problem only shows up at high RPM's, repeat the test while connected to a Dyno or on the water

**Mercury  
4 Stroke Ignitions  
Three Cylinder Engines 2000-2006  
F30/F40 2000-2006  
856178T 3-878433A 2 (67C-85540-01-00)**

**Service Notes: Please use the Factory recommended spark plug (currently NGK DPR6EA-9) gapped at 0.035".**  
**NOTE: Oil Pressure Light Triggers When Oil Pressure Falls Below 2.13 PSI.**

**NO SPARK OR WEAK SPARK:**

- Disconnect the White stop wire from the Ignition Module. Retest. If the engine's ignition now has spark, the stop circuit has a fault.
- Check the Stator, Trigger and ignition coil as follows:

| Check From:      | Check To:     | Ohms Reading:                            | DVA Reading Connected | Disconnected |
|------------------|---------------|--|-----------------------|--------------|
| Red/White        | Black         | 300 to 350                               | 6 V minimum           |              |
| Green/White      | Green/White   | 528 to 792                               | 193 V minimum         |              |
| Yellow/Black     | Yellow/Black  | 6.5 to 7.2                               | 7 V minimum           | 10 V minimum |
| Orange           | Black         | --                                       | 151 V minimum         |              |
| Spark Plug wires | Engine Ground | 2.7K (2700) to 3.7K (3700) (cap removed) |                       |              |

- Check the resistance of the ignition coil cap between the spark plug wire side and the spark plug side, you should read 4K-6K ohms.

**NO SPARK ON ONE CYLINDER:**

- Swap the ignition coil of the cylinder not firing with one that has fire. If the no fire problem follows the ignition coil, replace the ignition coil.
- If the ignition coil is good, replace the ECU.

**ENGINE WILL NOT ACCELERATE ABOVE APPROXIMATELY 2000 RPM:**

- Verify the engine is not overheating or has low oil pressure and causing the power pack to limit the RPM.
- Verify the oil pressure is over the minimum 2.13 PSI.
- Disconnect the Pink wire from the power pack and retest. If the engine now performs correctly, check the overheat sensor and oil pressure sensor mounted on the engine.
- Check ignition timing, it should be between approximately 5 degrees BTDC at idle to 28 degrees BTDC at about 3000. If the timing does not advance with RPM, replace the ignition pack.

**Four Stroke**

**HAS SPARK BUT WILL NOT RUN:**

1. Check spark plug for presence of water, indicating a possible cracked block or blown head gasket.
2. Check compression, carburetor, reed blocks and do a cylinder leak down test (remember, a valve not seating properly, stuck rings, improper tappet clearance, damaged piston or a blown head gasket can cause a low reading for a leak down test).
3. Replace the sparkplugs.
4. Check the Timing Belt and verify the cam timing is correct.
5. Make sure the throttle plates are fully closed (the engine will not start if the warm-up lever is raised).
6. Make sure the engine is getting fuel to the combustion chamber (no water or residue in the carburetor).
7. Check flywheel shear key to make sure it has not sheared due to backfiring or impact on the propeller.
8. Check the fuel in the carburetor. Check to see if there is a high ethanol content present. . If so, purge the fuel system with fresh fuel and see if the engine will start.
9. Check the fuel pressure AT THE CARBURETOR. You should see over 2 PSI. Check fuel lines for inner wall breakdown and wall collapse.
10. Check the Triggers as follows as a defective trigger can cause timing variance:

| Check From: | Check To: | Ohms Reading: | DVA Reading Connected | Disconnected |
|-------------|-----------|---------------|-----------------------|--------------|
| Red         | White     | 300 to 350    | 6 V minimum           | 6 V minimum  |

**WILL NOT STOP (KILL):**

1. Disconnect the White wire from the CD Module.
2. Short the White wire from the CD Module to engine ground. If the engine stops, the problem is in the stop circuit. If the engine continues to run with the White wire shorted to engine ground, replace the defective CD Module.

**WILL NOT CHARGE BATTERY:**

1. Check the resistance of the stator yellow wires as follows:

| Check From    | Check To      | Ohms Reading | DVA Reading Connected | Disconnected |
|---------------|---------------|--------------|-----------------------|--------------|
| Yellow        | Yellow        | 0.22 to 0.24 | 8 V minimum           | 8 V minimum  |
| Yellow (each) | Engine Ground | Open         | -                     | 1 V or less  |

2. Connect a inline ammeter between the regulator/rectifier's Red wire and the positive battery post on the starter solenoid. Connect a battery tester to the battery and start the engine. Increase the engine RPM to approximately 1500-2000 RPM and press the test button on the battery tester. The ammeter should show at least 3 amps of current flow. If not and the stator passes the test above, replace the regulator/rectifier. If the ammeter shows a charge, replace the battery. NOTE: If the problem only shows up at high RPM's, repeat the test while connected to a Dyno or on the water.

**Mercury**  
**4 Stroke Ignitions**  
**4 Cylinder Engines 1996-2005**  
**S/N: 0G2311123-UP**  
**40/50 HP by Yamaha**  
**40/45 HP 825098 1 (62Y-85540-02-00)**  
**50 HP 825098 3 (62Y-85540-02-00)**

**NO SPARK ON ONE CYLINDER:**

Replace the ignition coil.

**NO SPARK ON BOTH CYLINDERS:**

4. Disconnect the kill wire (White on pack – Black/Yellow in harness). If fire returns, the kill circuit is shorted. Possibly the Stop switch or harness.
5. Verify the correct sparks plugs are installed. OEM recommends NGK DPR6EA-9, gapped at 0.035 in.
6. Check the stator resistance and DVA output as given below:

| WIRE                              | READ TO              | OEM RESISTANCE         | DVA (Connected) |
|-----------------------------------|----------------------|------------------------|-----------------|
| Brown (Chg Coil)                  | Blue                 | 270-410                | 150 V-325V      |
| Green/Wht (Crank Position Sensor) | Black                | 230-350                | 2.5 V or more   |
| Orange                            | Black                | 0.16-0.24              | 150 V or more   |
| High Tension Lead #1              | High Tension Lead #2 | 3.9-5.9K without boots | --              |



**ENGINE WILL NOT ACCELERATE ABOVE APPROXIMATELY 3000 RPM:**

5. Verify the engine is not overheating and causing the power pack to limit the RPM.
6. Disconnect the Pink wire from the power pack and retest (Note: Some engines may have the Pink wire from the pack connected to a Brown/White wire in the harness). If the engine now performs correctly, check the overheat sensor, oil level in the oil tank mounted on the engine and the wiring harness.
7. Check the position of the Pink wire and make sure it is not next to a spark plug wire.
8. Check ignition timing, it should be between approximately 5 degrees at idle to 30 degrees BTDC at about 3000. If the timing does not advance with RPM, replace the ignition pack.

**NO WARNING LAMP:**

1. Short the Pink wire from the warning lamp to engine ground and crank the engine over. The lamp should light up.
2. If the warning lamp lights up, check the oil pressure switch. It should be shorted below 2.5 PSI and open above that.
3. If the lamp does not light up with the Pink wire shorted to ground, check the voltage on the Yellow/Red wire going to it. It should be over 3 volts. If the voltage is OK, replace the warning lamp.

**WARNING LAMP STAYS ON:**

If the warning lamp does not go off, check the oil pressure switch. It should be shorted below 2.5 PSI and open above that.

**Mercury  
4 Stroke Ignitions  
4 Cylinder Engines 1995-2005  
40/45//50 HP by Yamaha  
825098-1 50 HP 62Y-85540-02-00  
825098-3 40/45 HP**

**Service Notes: Please use the Factory recommended spark plug (currently NGK DPR6EA-9) gapped at 0.035".**

**NOTE: Oil Pressure Light Triggers When Oil Pressure Falls Below 4.3 PSI PSI.**

**NO SPARK OR WEAK SPARK:**

1. Disconnect the White stop wire from the Ignition Module. Retest. If the engine's ignition now has spark, the stop circuit has a fault.

2. Check the Stator, Trigger and ignition coil as follows:

| Check From:     | Check To:     | Ohms Reading:                              | DVA Reading   | Connected | Disconnected  |
|-----------------|---------------|--|---------------|-----------|---------------|
| Red/White       | White/Black   | 340 to 510                                 | 7 V minimum   |           | 6 V minimum   |
| Brown           | Blue          | 272 to 408                                 | 140 V minimum |           | 190 V minimum |
| Yellow/Black    | Yellow/Black  | 6.5 to 7.3                                 | 7 V minimum   |           | 10 V minimum  |
| Orange          | Black         |  | 105 V minimum |           |               |
| Spark Plug wire | Engine Ground | 3.28K (3280) to 4.92K (4920) (cap removed) |               |           |               |

3. Check the resistance of the ignition coil cap between the spark plug wire side and the spark plug side, you should read 3.8K (3800) to 5.7K (5700) ohms.

**NO SPARK ON TWO CYLINDERS:**

1. Swap the ignition coil of the cylinders not firing with one that has fire. If the no fire problem follows the ignition coil, replace the ignition coil.
2. If the ignition coil is good, replace the ECU.

**ENGINE KEEPS FOULING SPARK PLUGS:**

1. Check the stator DVA output as follows:

| Check From: | Check To: | Idle          | 1500 RPM      | 3500 RPM      |
|-------------|-----------|---------------|---------------|---------------|
| Brown       | Blue      | 140 V minimum | 150 V minimum | 135 V minimum |

2. Check the resistance of the ignition coils. You should read between 3.28K (3280) to 4.92K (4920) ohms for each coil.
3. Check the engine temperature. If the engine is not coming up to operating temperature, it will tend to foul the

**Four Stroke**

**ENGINE WILL NOT ACCELERATE ABOVE APPROXIMATELY 2000 RPM:**

1. Verify the engine is not overheating or low oil pressure, causing SAFE activation. Minimum 4.3 PSI oil.
2. Disconnect the Pink wire from the power pack and retest. If the engine now performs correctly, check the overheat sensor and oil pressure sensor mounted on the engine.
3. Check the ignition timing, it should be between approximately 5 degrees BTDC at idle to 35 degrees BTDC (30 degrees BTDC for 1995) at about 3000. If the timing does not advance with RPM, replace the ignition pack.

**HAS SPARK BUT WILL NOT RUN:**

1. Check spark plug for water, indicating a possible cracked block or blown head gasket.
2. Check compression, carburetor, reed blocks and do a cylinder leak down test (remember, a valve not seating properly, stuck rings, improper tappet clearance, damaged piston or a blown head gasket can cause a low reading for a leak down test).
3. Replace the sparkplugs.
4. Check the Timing Belt and verify the cam timing is correct.
5. Make sure the throttle plates are fully closed (the engine will not start if the warm-up lever is raised).
6. Verify the engine is getting fuel to the combustion chamber (make sure there is no water or residue in the carburetor). Check to see if there is a high ethanol content present. If so, purge the fuel system.
7. Check flywheel shear key to make sure it has not sheared due to backfiring or impact on the propeller.
8. Check the fuel pressure AT THE CARBURETOR. You should see over 2 PSI. Check fuel lines for inner wall breakdown and wall collapse.
9. Check the Triggers as follows as a defective trigger can cause timing variance:

| Check From: | Check To:   | Ohms Reading: | DVA Reading Connected | Disconnected |
|-------------|-------------|---------------|-----------------------|--------------|
| Red/White   | White/Black | 340 to 510    | 7 V minimum           | 6 V minimum  |

**WILL NOT STOP (KILL):**

1. Disconnect the White wire from the CD Module.
2. Short the White wire from the CD Module to engine ground. If the engine stops, the problem is in the stop circuit. If the engine continues to run with the White wire shorted to engine ground, replace the defective CD Module.

**WILL NOT CHARGE BATTERY:**

1. Check the resistance of the stator Green wires as follows:
 

| Check From   | Check To      | Ohms Reading | DVA Reading Connected | Disconnected |
|--------------|---------------|--------------|-----------------------|--------------|
| Green        | Green         | 1.2 to 1.8   | 8 V minimum           | 8 V minimum  |
| Green (each) | Engine Ground | Open         | -                     | 1 V or less  |
2. Connect a inline ammeter between the regulator/rectifier's Red wire and the battery post on the starter solenoid. Connect a battery tester to the battery and start the engine. Increase the engine RPM to approximately 1500-2000 RPM and press the test button on the battery tester. The ammeter should show at least 2 amps of current flow. If not and the stator passes the test above, replace the regulator/rectifier. If the ammeter shows a charge, replace the battery. NOTE: If the problem only shows up at high RPM's, repeat the test while connected to a Dyno or on the water.

**Tohatsu/Nissan**

**4 STROKE Engines**

**F4A, F4A2, F5A, F5A2, F6A and F6A2**

**NO SPARK:**

1. Disconnect the Black and Brown stop wires and retest. If you now have spark, the stop circuit has a fault.
2. Test the stator (exciter) and trigger (pulsar) stator coils while connected as follows:

| Red Lead  | Black Lead   | Resistance | DVA Connected |
|-----------|--------------|------------|---------------|
| Eng Gnd   | Black/Yellow |            | 90 V Minimum  |
| Black/Red | Eng Gnd      | 95-143     | 110 V Minimum |
| Red/White | Eng Gnd      | 49-223     | 2 V Minimum   |

If the above readings are OK and there is no spark, the ignition coil is likely defective.

**F8 and F9.8 HP**

**NO SPARK ON EITHER CYLINDER:**

1. Disconnect the Black and Brown stop wires and retest. If you now have spark, the stop circuit has a fault.
2. Test the stator (exciter) and trigger (pulsar) stator coils while connected as follows:

| Red Lead  | Black Lead | Resistance | DVA Connected |
|-----------|------------|------------|---------------|
| Eng Gnd   | Orange     |            | 90 V Minimum  |
| Blue      | Black/Red  | 238-352    | 110 V Minimum |
| Red/White | Eng Gnd    | 148-223    | 2 V Minimum   |

If the above readings are OK and there is no spark, the ignition coil is likely defective.

**NO SPARK ON ONE CYLINDER:**

If only one cylinder is firing, replace the ignition coil.

**F9.9A, F9.9B, F9.9B2, F9.9C, F15A, F15B, F15B2, F15C, F18B, F18B2 and F20C HP**

**NO SPARK ON EITHER CYLINDER:**

1. Disconnect the Black and Brown stop wires and retest. If you now have spark, the stop circuit has a fault.
2. Test the stator (exciter) and trigger (pulsar) stator coils while connected as follows:

| Red Lead  | Black Lead | Resistance | DVA Connected |
|-----------|------------|------------|---------------|
| Orange    | Eng Gnd    |            | 90 V Minimum  |
| Black/Red | Blue       | 12.6-18.6  | 110 V Minimum |
| Red/White | Eng Gnd    | 148-223    | 2 V Minimum   |

If the above readings are OK and there is no spark, the ignition coil is likely defective.

**NO SPARK ON ONE CYLINDER:**

If only one cylinder is firing, replace the ignition coil.

**ENGINE LOW ON POWER OR IDLING ROUGH:**

1. Check or replace the spark plugs.
2. Check the ignition coil for good spark on both sparkplug leads. REMEMBER: DO NOT FIRE THE COIL WITH THE SPARKPLUG LEADS DISCONNECTED. Both leads have to be connected to a spark tester when checking for spark.
3. Check the engine oil to see if it is overfull. If the oil smells of gasoline, the customer may be leaving the fuel line connected, allowing the fuel tank pressure to over-ride the float in the carburetor. Check carburetor float for flexing, allowing the engine to flood the cylinders with gas.
4. Check fuel lines for restrictions.

**ENGINE WILL NOT EXCEED 2000 RPMS:**

1. Check the oil pressure light. If the light is staying on, check the oil pressure.
2. If the oil pressure is OK, test the oil pressure sensor. It should open up at approximately 3.5-4 PSI.
3. If both the oil pressure and sensor test OK, the CD could be defective.

**Four Stroke**

## F25A and F30A

### NO SPARK ON ANY CYLINDER:

1. Disconnect the Black and Brown stop wires and retest. If you now have spark, the stop circuit has a fault.
2. Check the 12 Volt power to the ignition pack from the rectifier. It should not drop below 10 volts at cranking.
3. If you do not show the correct voltage at the CD, test or replace the battery with a fully charged battery. If you still do not show the correct voltage at the CD, use a jumper wire and connect the CD directly to the battery post of the starter solenoid for 12V DC. If you get spark back, replace the rectifier/regulator.

4. Test the trigger (pulsar) and ignition pack output while connected as follows:

| Red Lead    | Black Lead | Resistance | DVA Connected |
|-------------|------------|------------|---------------|
| White/Red   | Eng Gnd    | 168-252    | 2 V Minimum   |
| White/Black | Eng Gnd    | 168-252    | 2 V Minimum   |
| White/Blue  | Eng Gnd    | 168-252    | 2 V Minimum   |
| Black/White | Eng Gnd    |            | 110 V Minimum |
| Black/Red   | Eng Gnd    |            | 110 V Minimum |
| Black/Green | Eng Gnd    |            | 110 V Minimum |
| Plug Wire   | Eng Gnd    | 2.56-3.84K |               |

If the above readings are OK and there is no spark, the ignition coil is likely defective.

### NO SPARK ON ONE OR MORE CYLINDERS:

1. Swap the ignition coil from the cylinder not firing to one that does. If the no fire follows the coil, replace it.
2. Disconnect the Yellow and White wires from the Rectifier/Regulator. If the miss is gone, replace the regulator/rectifier.

3. Test the CDI output as follows:

| Red Lead    | Black Lead | DVA Connected |
|-------------|------------|---------------|
| Black/White | Eng Gnd    | 110 V Minimum |
| Black/Red   | Eng Gnd    | 110 V Minimum |
| Black/Green | Eng Gnd    | 110 V Minimum |

4. Test the trigger (pulsar) stator coils as follows:

| Red Lead    | Black Lead | Resistance | DVA Connected |
|-------------|------------|------------|---------------|
| White/Red   | Eng Gnd    | 168-252    | 2 V Minimum   |
| White/Black | Eng Gnd    | 168-252    | 2 V Minimum   |
| White/Blue  | Eng Gnd    | 168-252    | 2 V Minimum   |

### ENGINE HAS A MID-RANGE MISS OR WILL NOT GO OVER 2800 RPM :

1. Verify the warning light and horn is working properly by grounding the overheat sensor in the cylinder head or the oil pressure sensor.
2. Check for blown fuses. NOTE: Sometimes a fuse will open up but appear to be OK, meter across it.
2. Check the 12 Volt power to the ignition pack from the rectifier. If you do not show the correct voltage at the CD, test or replace the battery with a fully charged battery. If you still do not show the correct voltage at the CD, use a jumper wire and connect the CD directly to the battery post of the starter solenoid for 12V DC. If you get spark back, replace the rectifier/regulator.
3. Monitor the stator and trigger coils DVA voltage. It should not drop significantly right before the miss becomes apparent.

| Red Lead    | Black Lead | Resistance | DVA Connected |
|-------------|------------|------------|---------------|
| White/Red   | Eng Gnd    | 168-252    | 2 V Minimum   |
| White/Black | Eng Gnd    | 168-252    | 2 V Minimum   |
| White/Blue  | Eng Gnd    | 168-252    | 2 V Minimum   |
| Black/White | Eng Gnd    |            | 110 V Minimum |
| Black/Red   | Eng Gnd    |            | 110 V Minimum |
| Black/Green | Eng Gnd    |            | 110 V Minimum |

4. Disconnect the Light Blue warning wire going into the CDI unit. If the engine performs normally, re-connect the Light Blue wire to the CDI unit.
  - A) Disconnect Light Blue wire to the oil sensor. Retest engine. If the engine performs normally, replace the oil sensor. If the miss is still present, re-connect the Light Blue wire to the oil sensor.
  - B) Disconnect Light Blue wire to the water pressure sensor. Retest engine. If the engine performs normally, replace the water pressure sensor.
  - C) Disconnect Light Blue wire to the overheat temperature sensor. Retest engine. If the engine performs normally, replace the overheat temperature sensor.

**ENGINE WILL NOT EXCEED 2000 RPMS:**

Check the oil pressure light. If the light is staying on, check the oil pressure. If the oil pressure is OK, replace the oil sending unit.

**F25B and F30B HP EFI**

**NO SPARK ON ANY CYLINDER:**

1. Disconnect the Black and Brown stop wires and retest. If you now have spark, the stop circuit has a fault.
2. Test the trigger (pulsar) and stator coils DVA (while connected) and resistance (disconnected) as follows:

| Red Lead     | Black Lead  | Resistance | DVA Connected |
|--------------|-------------|------------|---------------|
| White/Red    | White/Black | 12-19      | 110 V Minimum |
| White/Blue   | White/Black |            | 10 V Minimum  |
| Red/Yellow   | Eng Gnd     | 168-252    | 2 V Minimum   |
| Red/White    | Eng Gnd     | 168-252    | 2 V Minimum   |
| Black/White  | Eng Gnd     |            | 10 V Minimum  |
| Black/Yellow | Eng Gnd     |            | 110 V Minimum |
| Black/Green  | Eng Gnd     |            | 110 V Minimum |
| Plug Wire    | Eng Gnd     | 3.28-4.92K |               |

**TIMING FLUCTUATES:**

Service Notes: It is normal for timing to fluctuate 1 to 2° @ idle.

1. Clean and inspect all ground connections.
2. Check the Crank Position Sensor resistance as given below:

| Red Lead   | Black Lead | Resistance | DVA Connected |
|------------|------------|------------|---------------|
| Red/Yellow | Eng Gnd    | 168-252    | 2 V Minimum   |
| Red/White  | Eng Gnd    | 168-252    | 2 V Minimum   |

3. Check the Throttle Position Sensor and the Engine Temperature Sensor.
4. Check the ECU.

**TIMING WILL NOT ADVANCE:**

1. Check the Throttle Position Sensors.
2. Check the ECU. Swap with a known good ECU if available.

**ENGINE MISSES AT HIGH RPM:**

1. Check for correct spark plugs and sparkplug gag (See data sticker on engine).
2. Check the Crank Position Sensor.
3. Clean all engine ground connections and power connections.
4. Check the battery voltage at the engine. If high, check at the battery. If it is high at the engine but OK at the battery, perform a voltage drop test.
5. Check the ECU.

**ENGINE HARD TO START WHEN COLD:**

1. Check the Engine Temperature Sensor
2. If the engine is electric start, check the battery voltage while cranking (battery voltage should remain over 10 volts). Try another battery and see if the problem goes away. If so, replace the battery.
3. Check the Harness for loose connections between ECU and Starter Solenoid.

**ENGINE MISSES @ LOW RPM, BUT RUNS SMOOTH @ HIGH RPM:**

Check the Harness for loose connections between ECU and Ignition Modules.

**ENGINE STARTS HARD WHEN HOT:**

1. Check the Engine Temperature Sensor and the Crank Position Sensor.
2. Check the VST and fuel pump housing to see if they are too hot. If so, check the fuel cooler for a blockage.

**ENGINE WILL NOT RUN OVER 2800 RPM AND IS NOT OVERHEATING:**

1. Check the Engine Temperature Sensor and the MAP Sensor.
2. Check the ECU, Throttle Position Sensor and Neutral Switch for loose connections.
3. Check the Oil pressure sensor and pressure.



**ENGINE WILL NOT ACCELERATE OR BOGS ON ACCELERATION:**

1. Check the throttle plate operation and synchronization.
2. Check the Throttle Position Sensor and MAP sensor.



**KEEPING YOUR BOAT ON THE WATER**

## **Over 900 Products**

The broadest coverage of marine ignition products on the market

### **Diagnostic Toolbox**

#### **INCLUDES**

Multimeter  
Spark Tester  
Trigger Tester  
Neon Test Light  
Piercing Probe Set  
DVA Adapter  
Pack Load Resistor

Multimeter Test Card  
Amphenol Pin Tool Set  
Terminal Kit  
Troubleshooting Guide  
Laminated DVA Charts  
Aluminum Storage Case



### **High Performance Spark Plug Wire Set**

#### **FEATURES**

8mm Wire  
Kevlar Core  
More Spark Energy  
Better EMI Suppression  
Higher Dielectric Strength



*Proven performance when tested against 7 other popular brands!*

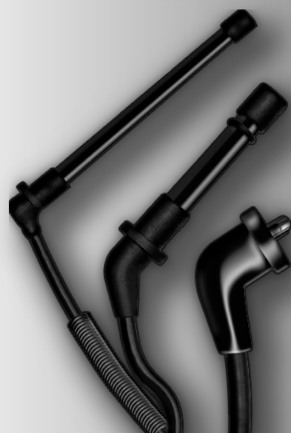

1.800.467.3371 • [www.cdielelectronics.com](http://www.cdielelectronics.com)

**Yamaha  
4 Stroke Engines**

**F4 (4 HP) 1999-2005**

**Service Notes: Please use the Factory recommended spark plug (currently NGK B6HS) gapped at 0.024" .**

**NO SPARK OR WEAK SPARK :**

1. Disconnect the White stop wire from the Transistorized Control Ignition Module (TCI). Retest. If the engine's ignition now has spark, the stop circuit has a fault.
2. Inspect and clean all engine and ignition ground connections.
3. Check Transistorized Control Ignition Module (TCI) DVA output to coil, 126V minimum.
4. Remove the spark plug cap from the ignition coil and measure the resistance through it. It should read from 4K (4000) to 6K (6000) ohms.
5. Check the resistance of the ignition coil between the Black/White and Black primary wires, you should read 0.56 to 0.84 ohms.
6. Check the resistance of the ignition coil between the secondary (spark plug wire) and Black wires, you should read 11.6K (11600) to 17.40K (17400) ohms.

**F6, F8, T8**

**F6 HP 2001-2008**

**F8-T8 HP 2001-2011**

**68R-85540-00-00/68T-85540-00-00**

**Service Notes: Please use the Factory recommended spark plug (currently NGK BR6HS-10) gapped at 0.039" .**

**NO SPARK OR WEAK SPARK :**

1. Disconnect the White stop wire from the Ignition Module. Retest. If the engine's ignition now has spark, the stop circuit has a fault.
2. Inspect and clean all engine and ignition ground connections.
3. Check the Stator, Trigger and ignition coil as follows:

| Check From:         | Check To:         | Ohms Reading:                                  | DVA Reading Connected |
|---------------------|-------------------|--|-----------------------|
| White/Red           | Black             | 240 to 360                                     | 3.5 V Minimum         |
| Brown (Charge Coil) | Blue              | 232 to 348                                     | 154 V Minimum         |
| Orange              | Black             | 0.48-0.72 Disconnected                         | 140 V Minimum         |
| Spark Plug lead #1  | Spark Plug Lead # | 27K (7000) to 10.5K (10,500) with caps removed |                       |

4. Remove the spark plug cap from the ignition coil and measure the resistance through it. It should read from 3.44K (3440) to 5.16K (5160) ohms.
5. Check the resistance of the ignition coil between the Orange and Black primary wires, you should read 0.48-0.72 ohms.

**F9.9, FT9.9, T9.9 HP 1985-2005**

**2 Cylinder 4 Stroke**

**6G9-85540-21-00 (117-6921)/6G8-85540-29-00**

**NO SPARK ON BOTH CYLINDERS:**

1. Disconnect the White kill wire. If fire returns, the kill circuit is shorted. Possibly the Stop switch or harness.
1. Inspect and clean all engine and ignition ground connections.
1. Verify the correct sparks plugs are installed. OEM recommends NGK CR6HS, gapped at 0.024 in.
2. Check the stator resistance and DVA output as given below:

| WIRE                 | READ TO              | OEM RESISTANCE         | DVA (Connected) |
|----------------------|----------------------|------------------------|-----------------|
| Brown (Chg Coil)     | Blue                 | 569-695 (1984-1990)    | 100 V Minimum   |
| Brown (Chg Coil)     | Blue                 | 280-480 (1991-2004)    | 90 V Minimum    |
| White/Red            | Black                | 172-212 (1984-1990)    | 2.5 V Minimum   |
| White/Red            | Black                | 168-252 (1991-2004)    | 2.5 V Minimum   |
| Orange               | Black                | 0.16-0.24              | 85 V Minimum    |
| High Tension Lead #1 | High Tension Lead #2 | 2.89-3.81K (1984-1990) | --              |
| High Tension Lead #1 | High Tension Lead #2 | 3.48-4.7K (1991-2004)  | --              |

**NO SPARK ON ONE CYLINDER:**

Replace the ignition coil.

**Four Stroke**

**ENGINE WILL NOT ACCELERATE ABOVE APPROXIMATELY 2000 RPM:**

1. Verify the engine is not overheating and causing the power pack to limit the RPM.
2. Disconnect the Pink wire from the power pack and retest. If the engine now performs correctly, check the overheat sensor, oil level sensor in the oil tank mounted on the engine and the wiring harness.
3. Check the position of the Pink wire and make sure it is not next to a spark plug wire.
4. Check the ignition timing; it should be between approximately 2-8 degrees BTDC at idle to 32-38 degrees BTDC at about 3000. If the timing does not advance with RPM, replace the ignition pack.

**HAS SPARK BUT WILL NOT RUN:**

1. Make sure the engine is getting fuel to the combustion chamber (make sure there is no water or residue in the carburetor).
2. Check flywheel shear key to make sure it has not sheared due to backfiring or impact on the propeller.
3. Check flywheel magnet to make sure it has broken loose and moved, causing a timing shift.
4. Check spark plug for presence of water, indicating a possible cracked block or blown head gasket.
5. Check compression, carburetor, reeds and do a cylinder leak down test.
6. Check the fuel in the carburetor. Check to see if a very high ethanol content is present. . If so, purge the fuel system with fresh fuel and see if the engine will start.
7. Check the fuel pressure AT THE CARBURETOR. You should see over 2 PSI. Check fuel lines for inner wall breakdown and wall collapse.

8. Check the Triggers as follows as a defective trigger can cause timing variance:

| Check From: | Check To: | Ohms Reading:       | DVA Reading: |
|-------------|-----------|---------------------|--------------|
| White/Red   | Black     | 172-212 (1984-1990) | 2.5V Minimum |
| White/Red   | Black     | 168-252 (1991-2004) | 2.5V Minimum |

**WILL NOT STOP (KILL):**

1. Disconnect the White wire from the CD Module.
2. Short the White wire from the CD Module to engine ground. If the engines stops, the problem is in the stop circuit. If the engine continues to run with the White wire shorted to engine ground, replace the defective CD Module.

**F9.9, T9.9 HP 2005-2006  
2 Cylinder 4 Stroke 66R/66N Series  
66M-85540-01-00**

**NO SPARK ON BOTH CYLINDERS:**

1. Disconnect the White kill wire. If fire returns, the kill circuit is shorted. Possibly the Stop switch or harness.
1. Inspect and clean all engine and ignition ground connections.
2. Verify the correct sparks plugs are installed. OEM recommends NGK DPR6EA-9, gapped at 0.040 in.
3. Check the stator resistance and DVA output as given below:

| WIRE                 | READ TO              | OEM RESISTANCE | DVA (Connected) |
|----------------------|----------------------|----------------|-----------------|
| Brown (Chg Coil)     | Blue                 | 272-408        | 135 V Minimum   |
| White/Green          | Black                | 234-348        | 3.5 V Minimum   |
| Orange               | Black                | 0.16-0.24      | 115 V Minimum   |
| High Tension Lead #1 | High Tension Lead #2 | 3.93-5.89K     | --              |

**NO SPARK ON ONE CYLINDER:** Replace the ignition coil.

**ENGINE WILL NOT ACCELERATE ABOVE APPROXIMATELY 2000 RPM:**

1. Verify the engine is not overheating and causing the power pack to limit the RPM.
2. Disconnect the Pink wire from the power pack and retest. If the engine now performs correctly, check the overheat sensor, oil level sensor in the oil tank mounted on the engine and the wiring harness.
3. Check the ignition timing, it should be between approximately 2-8 degrees BTDC at idle to 27-33 degrees BTDC at WOT. If the timing does not advance with RPM, replace the ignition pack.

**HAS SPARK BUT WILL NOT RUN:**

1. Make sure the engine is getting fuel to the combustion chamber (make sure there is no water or residue in the carburetor).
2. Check flywheel shear key to make sure it has not sheared due to backfiring or impact on the propeller.
3. Check flywheel magnet to make sure it has broken loose and moved, causing a timing shift.

4. Check spark plug for presence of water, indicating a possible cracked block or blown head gasket.
5. Check compression, carburetor, reed block and do a cylinder leak down test.
6. Check the fuel in the carburetor. Check to see if a high ethanol content is present. . If so, purge the fuel system with fresh fuel and see if the engine will start.
7. Check the fuel pressure AT THE CARBURETOR. You should see over 2 PSI. Check fuel lines for inner wall breakdown and wall collapse.
8. Check the Trigger as follows as a defective trigger can cause timing variance:
 

| Check From: | Check To: | Ohms Reading: | DVA Reading:  |
|-------------|-----------|---------------|---------------|
| White/Green | Black     | 234-348       | 3.5 V Minimum |

**WILL NOT STOP (KILL):**

1. Disconnect the White wire from the CD Module.
2. Short the White wire from the CD Module to engine ground. If the engine stops, the problem is in the stop circuit. If the engine continues to run with the White wire shorted to engine ground, replace the defective CD Module.

**F8 T8 F9.9 T9.9 HP 2007-2013 - 2 Cylinder 4 Stroke  
68T-85540-00-00**

**NO SPARK ON BOTH CYLINDERS:**

1. Disconnect the White kill wire. If fire returns, the kill circuit is shorted. Possibly the Stop switch or harness.
1. Inspect and clean all engine and ignition ground connections.
2. Verify the correct sparks plugs are installed. OEM recommends NGK BPR6HS-10S, gapped at 0.039 in.
3. Check the stator resistance and DVA output as given below:

| WIRE                 | READ TO              | OEM RESISTANCE            | DVA (Connected) |
|----------------------|----------------------|---------------------------|-----------------|
| Brown (Chg Coil)     | Blue                 | 232-348                   | 160 V Minimum   |
| White/Red            | Black                | 240-360                   | 3.5 V Minimum   |
| Orange               | Black                | 0.26-0.35                 | 140 V Minimum   |
| High Tension Lead #1 | High Tension Lead #2 | 3.93-5.89K (caps removed) | --              |
| Spark Plug Cap       | -                    | 4K-6K through the cap     |                 |

**NO SPARK ON ONE CYLINDER:**

1. Check the ignition coil as follows:

| WIRE                 | READ TO              | OEM RESISTANCE            |
|----------------------|----------------------|---------------------------|
| High Tension Lead #1 | High Tension Lead #2 | 3.93-5.89K (caps removed) |
| Spark Plug Cap       | -                    | 4K-6K through the cap     |

2. Replace the ignition coil.

**ENGINE WILL NOT ACCELERATE ABOVE APPROXIMATELY 2000 RPM:**

1. Verify the engine is not overheating and causing the power pack to limit the RPM.
2. Disconnect the Pink wire from the power pack and retest. If the engine now performs correctly, check the overheat sensor and oil pressure sensor mounted on the engine.
3. Check the position of the Pink wire and make sure it is not next to a spark plug wire.
4. Check the ignition timing; it should be between approximately 2-8 degrees BTDC at idle to 27-33 degrees BTDC at about 3000. If the timing does not advance with RPM, replace the ignition pack.

**HAS SPARK BUT WILL NOT RUN:**

1. Verify the sparkplug gap. The specifications may have changed. Gap should be 0.037-0.039.
2. Make sure the throttle plates are closed (the engine will not start if the warm-up lever is raised).
3. Make sure the engine is getting fuel to the combustion chamber (make sure there is no water or residue in the carburetor).
4. Check flywheel shear key to make sure it has not sheared due to backfiring or impact on the propeller.
5. Check flywheel magnet to make sure it has broken loose and moved, causing a timing shift.
6. Check spark plug for presence of water, indicating a possible cracked block or blown head gasket.
7. Check compression, carburetor, reeds and do a cylinder leak down test.
8. Check the fuel in the carburetor. Check to see if a very high ethanol content is present. . If so, purge the fuel system with fresh fuel and see if the engine will start.
9. Check the fuel pressure AT THE CARBURETOR. You should see over 2 PSI. Check fuel lines for inner wall breakdown and wall collapse.

**Four Stroke**

10. Check the Trigger as follows as a defective trigger can cause timing variance:

| Check From: | Check To: | Ohms Reading: | DVA Reading:  |
|-------------|-----------|---------------|---------------|
| White/Red   | Black     | 240-360       | 3.5 V Minimum |

**WILL NOT STOP (KILL):**

1. Disconnect the White wire from the CD Module.
2. Short the White wire from the CD Module to engine ground. If the engine stops, the problem is in the stop circuit. If the engine continues to run with the White wire shorted to engine ground, replace the defective CD Module.

**F15 1998-2006  
66M-85540-01-00**

**Service Notes: Please use the Factory recommended spark plug (currently NGK DPR6EA-9) gapped at 0.040”.**

NOTE: Oil Pressure Light Triggers When Oil Pressure Falls Below 7 PSI.

**NO SPARK OR WEAK SPARK :**

1. Disconnect the White stop wire from the Ignition Module. Retest. If the engine's ignition now has spark, the stop circuit has a fault.
2. Inspect and clean all engine and ignition ground connections.
3. Check the Stator, Trigger and ignition coil as follows:

| Check From:          | Check To:            | Ohms Reading:             | DVA Reading     |
|----------------------|----------------------|---------------------------|-----------------|
| White/Red            | Black                | 234 to 348                | 3.5 V Connected |
| Brown                | Black                | 272 to 408                | 135 V Connected |
| Orange               | Black                | 0.16-0.24                 | 15 V @ Cranking |
| High Tension Lead #1 | High Tension Lead #2 | 3.93-5.89K (caps removed) |                 |

**NO SPARK ON ONE CYLINDER:**

Replace the ignition coil.

**ENGINE WILL NOT ACCELERATE ABOVE APPROXIMATELY 2000 RPM:**

1. Verify the engine is not overheating and causing the power pack to limit the RPM.
2. Disconnect the Pink wire from the power pack and retest. If the engine now performs correctly, check the overheat sensor and oil pressure sensor mounted on the engine.
3. Check the position of the Pink wire and make sure it is not next to a spark plug wire.
4. Check the ignition timing; it should be between approximately 2-8 degrees BTDC at idle to 272-33 degrees BTDC at about 3000. If the timing does not advance with RPM, replace the ignition pack.

**HAS SPARK BUT WILL NOT RUN:**

1. Verify the sparkplug gap. The specifications may have changed. Gap should be 0.024-0.028.
2. Make sure the throttle plates are closed (the engine will not start if the warm-up lever is raised).
3. Make sure the engine is getting fuel to the combustion chamber (make sure there is no water or residue in the carburetor).
4. Check flywheel shear key to make sure it has not sheared due to backfiring or impact on the propeller.
5. Check flywheel magnet to make sure it has broken loose and moved, causing a timing shift.
6. Check spark plug for presence of water, indicating a possible cracked block or blown head gasket.
7. Check compression, carburetor, reeds and do a cylinder leak down test.
8. Check the fuel in the carburetor. Check to see if a very high ethanol content is present. . If so, purge the fuel system with fresh fuel and see if the engine will start.
9. Check the fuel pressure AT THE CARBURETOR. You should see over 2 PSI. Check fuel lines for inner wall breakdown and wall collapse.

10. Check the Triggers as follows as a defective trigger can cause timing variance:

| Check From: | Check To: | Ohms Reading: | DVA Reading Connected | Disconnected |
|-------------|-----------|---------------|-----------------------|--------------|
| White/Red   | Black     | 234 to 348    | 3.5 V minimum         | 4 V          |

**WILL NOT STOP (KILL):**

1. Disconnect the White wire from the CD Module.
2. Short the White wire from the CD Module to engine ground. If the engine stops, the problem is in the stop circuit. If the engine continues to run with the White wire shorted to engine ground, replace the defective CD Module.



**F15C/20 2006-2013  
6AH-85540-00-00**

**Service Notes: Please use the Factory recommended spark plug (currently NGK DPR6EA-9) gapped at 0.040".  
NOTE: Oil Pressure Light Triggers When Oil Pressure Falls Below 7 PSI.**

**NO SPARK OR WEAK SPARK:**

1. Disconnect the White stop wire from the Ignition Module. Retest. If the engine's ignition now has spark, the stop circuit has a fault.
2. Inspect and clean all engine and ignition ground connections.
3. Check the Stator, Trigger and ignition coil as follows:

| Check From:        | Check To:          | Ohms Reading:                                | DVA Reading Connected | Disconnected |
|--------------------|--------------------|--|-----------------------|--------------|
| White/Red          | Black              | 152 to 228                                   | 2.6 V minimum         | 4 V minimum  |
| Black/Red          | Green/Red          | 26 to 36                                     | 140 V minimum         | 60 V minimum |
| Orange             | Black              | 0.26-0.34                                    | 140 V minimum         |              |
| Spark Plug wire #1 | Spark Plug Wire #2 | 6.8K (6800) to 10.0K (10,000) (caps removed) |                       |              |
| Spark Plug Cap     |                    | 3.75-6.25K                                   |                       |              |

4. Remove the spark plug cap from the ignition coil and measure the resistance through it. It should read from 3.75K (3750) to 6.25K (6250) ohms.
5. Check the resistance of the ignition coil between the Black/White and Black primary wires, you should read 0.26 to 0.34 ohms.
6. Check the resistance of the ignition coil between the secondary (spark plug) wires, you should read 6.8K (6800) to 10K (10,000) ohms.

**NO SPARK ON ONE CYLINDER:**

Replace the ignition coil.

**ENGINE WILL NOT ACCELERATE ABOVE APPROXIMATELY 2000 RPM:**

1. Verify the engine is not overheating and causing the power pack to limit the RPM.
2. Disconnect the Pink wire from the power pack and retest. If the engine now performs correctly, check the overheat sensor and oil pressure sensor mounted on the engine.
3. Check the position of the Pink wire and make sure it is not next to a spark plug wire.
4. Check the ignition timing; it should be between approximately 27-33 degrees BTDC at about 3000. If the timing does not advance with RPM, replace the ignition pack.

**HAS SPARK BUT WILL NOT RUN:**

1. Verify the sparkplug gap. The specifications may have changed. Gap should be 0.040.
2. Make sure the throttle plates are closed (the engine will not start if the warm-up lever is raised).
3. Make sure the engine is getting fuel to the combustion chamber (make sure there is no water or residue in the carburetor).
4. Check flywheel shear key to make sure it has not sheared due to backfiring or impact on the propeller.
5. Check flywheel magnet to make sure it has broken loose and moved, causing a timing shift.
6. Check spark plug for presence of water, indicating a possible cracked block or blown head gasket.
7. Check compression, carburetor, reeds and do a cylinder leak down test.
8. Check the fuel in the carburetor. Check to see if a very high ethanol content is present. . If so, purge the fuel system with fresh fuel and see if the engine will start.
9. Check the fuel pressure AT THE CARBURETOR. You should see over 2 PSI. Check fuel lines for inner wall breakdown and wall collapse.
10. Check the Triggers as follows as a defective trigger can cause timing variance:

| Check From: | Check To: | Ohms Reading: | DVA Reading Connected | Disconnected |
|-------------|-----------|---------------|-----------------------|--------------|
| White/Red   | Black     | 152 to 228    | 2.6 V minimum         | 4 V minimum  |

**WILL NOT STOP (KILL):**

1. Disconnect the White wire from the CD Module.
2. Short the White wire from the CD Module to engine ground. If the engine stops, the problem is in the stop circuit. If the engine continues to run with the White wire shorted to engine ground, replace the defective CD Module.

**Four Stroke**

**F25 1998-2005/T25 2001-2006  
65W-85540-00-00**

**Service Notes: Please use the Factory recommended spark plug (currently NGK DPR6EA-9) gapped at 0.035".**  
**NOTE: Oil Pressure Light Triggers When Oil Pressure Falls Below 2.13 PSI.**

**NO SPARK OR WEAK SPARK:**

4. Disconnect the White stop wire from the Ignition Module. Retest. If the engine's ignition now has spark, the stop circuit has a fault.
5. Inspect and clean all engine and ignition ground connections.
6. Check the Stator, Trigger and ignition coil as follows:

| Check From:        | Check To:          | Ohms Reading: | DVA Reading Connected        | Disconnected  |
|--------------------|--------------------|---------------|------------------------------|---------------|
| Red                | White              | 260 to 390    | 6 V minimum                  | 6 V minimum   |
| Green/White        | Green/White        | 660 to 710    | 190 V minimum                | 190 V minimum |
| Yellow/Black       | Yellow/Black       | 6.5 to 7.3    | 7 V minimum                  | 10 V minimum  |
| Orange             | Black              |               | 100 V minimum                |               |
| Spark Plug wire #1 | Spark Plug wire #2 |               | 3.28K (3280) to 4.92K (4920) |               |

7. Check the resistance of the ignition coil between the secondary (spark plug wire) and Black wires, you should read 3.28K (3280) to 4.92K (4920) ohms.

**NO SPARK ON ONE CYLINDER:** Replace the ignition coil.

**ENGINE WILL NOT ACCELERATE ABOVE APPROXIMATELY 2000 RPM:**

6. Verify the engine is not overheating and the oil pressure is over the minimum 2.13 PSI causing the power pack to limit the RPM.
7. Disconnect the Pink wire from the power pack and retest. If the engine now performs correctly, check the overheat sensor and oil pressure sensor mounted on the engine.
8. Check the ignition timing; it should be between approximately 4.5-10.5 degrees BTDC at idle to 27-33 degrees BTDC at about 3000. If the timing does not advance with RPM, replace the ignition pack.

**HAS SPARK BUT WILL NOT RUN:**

11. Verify the sparkplug gap. The specifications may have changed. Gap should be 0.024-0.028.
12. Make sure the throttle plates are closed (the engine will not start if the warm-up lever is raised).
13. Make sure the engine is getting fuel to the combustion chamber (make sure there is no water or residue in the carburetor).
14. Check flywheel shear key to make sure it has not sheared due to backfiring or impact on the propeller.
15. Check flywheel magnet to make sure it has broken loose and moved, causing a timing shift.
16. Check spark plug for presence of water, indicating a possible cracked block or blown head gasket.
17. Check compression, carburetor, reeds and do a cylinder leak down test.
18. Check the fuel in the carburetor. Check to see if a very high ethanol content is present. . If so, purge the fuel system with fresh fuel and see if the engine will start.
19. Check the fuel pressure AT THE CARBURETOR. You should see over 2 PSI. Check fuel lines for inner wall breakdown and wall collapse.
20. Check the Triggers as follows as a defective trigger can cause timing variance:

| Check From: | Check To: | Ohms Reading: | DVA Reading Connected | Disconnected |
|-------------|-----------|---------------|-----------------------|--------------|
| Red         | White     | 260 to 390    | 6 V minimum           | 6 V minimum  |

**WILL NOT STOP (KILL):**

3. Disconnect the White wire from the CD Module.
4. Short the White wire from the CD Module to engine ground. If the engine stops, the problem is in the stop circuit. If the engine continues to run with the White wire shorted to engine ground, replace the defective CD Module.

**WILL NOT CHARGE BATTERY:**

1. Check the resistance of the stator yellow wires as follows:

| Check From | Check To      | Ohms Reading | DVA Reading Connected | Disconnected |
|------------|---------------|--------------|-----------------------|--------------|
| Yellow     | Yellow        | 0.22 to 0.24 | 8 V minimum           | 8 V minimum  |
| Yellow     | Engine Ground | Open         | -                     | 1 V or less  |

2. Connect an inline ammeter between the regulator/rectifier and the positive battery post on the starter solenoid.

Connect a battery tester to the battery and start the engine. Increase the engine RPM to approximately 1500-2000 RPM and press the test button on the battery tester. The ammeter should show at least 3 amps of current flow. If not and the stator passes the test above, replace the regulator/rectifier. If the ammeter shows a charge, replace the battery. NOTE: If the problem only shows up at high RPM's, repeat the test while connected to a Dyno or on the water.]

**F30 (3 Cyl) 2001-2006**

**F40 (3 Cyl) 2000-2006**

**67C-85540-01-00**

**Service Notes: Please use the Factory recommended spark plug (currently NGK DPR6EA-9) gapped at 0.035".**  
**NOTE: Oil Pressure Light Triggers When Oil Pressure Falls Below 2.13 PSI.**

**NO SPARK OR WEAK SPARK:**

1. Disconnect the White stop wire from the Ignition Module. Retest. If the engine's ignition now has spark, the stop circuit has a fault. Inspect and clean all engine and ignition ground connections.
2. Inspect and clean all engine and ignition ground connections.
3. Check the Stator, Trigger and ignition coil as follows:

| Check From:      | Check To:     | Ohms Reading:                            | DVA Reading Connected | Disconnected |
|------------------|---------------|--|-----------------------|--------------|
| Red/White        | Black         | 300 to 350                               | 6 V minimum           |              |
| Green/White      | Green/White   | 528 to 792                               | 193 V minimum         |              |
| Yellow/Black     | Yellow/Black  | 6.5 to 7.2                               | 7 V minimum           | 10 V minimum |
| Orange           | Black         |  | 151 V minimum         |              |
| Spark Plug wires | Engine Ground | 2.7K (2700) to 3.7K (3700) (cap removed) |                       |              |

4. Check the resistance of the ignition coil cap between the spark plug wire side and the spark plug side, you should read 4K-6K ohms.

**NO SPARK ON ONE CYLINDER:**

1. Swap the ignition coil of the cylinder not firing with one that has fire. If the no fire problem follows the ignition coil, replace the ignition coil.
2. If the ignition coil is good, replace the ECU.

**ENGINE WILL NOT ACCELERATE ABOVE APPROXIMATELY 2000 RPM:**

1. Verify the engine is not overheating or has low oil pressure and causing the power pack to limit the RPM.
2. Verify the oil pressure is over the minimum 2.13 PSI.
3. Disconnect the Pink wire from the power pack and retest. If the engine now performs correctly, check the overheat sensor and oil pressure sensor mounted on the engine.
4. Check the ignition timing; it should be between approximately 5 degrees BTDC at idle to 28 degrees BTDC at about 3000. If the timing does not advance with RPM, replace the ignition pack.

**HAS SPARK BUT WILL NOT RUN:**

1. Check spark plug for presence of water, indicating a possible cracked block or blown head gasket.
2. Check compression, carburetor, reed blocks and do a cylinder leak down test (remember, a valve not seating properly, stuck rings, improper tappet clearance, damaged piston or a blown head gasket can cause a low reading for a leak down test).
3. Replace the sparkplugs.
4. Check the Timing Belt and verify the cam timing is correct.
5. Make sure the throttle plates are fully closed (the engine will not start if the warm-up lever is raised).
6. Make sure the engine is getting fuel to the combustion chamber (no water or residue in the carburetor).
7. Check flywheel shear key to make sure it has not sheared due to backfiring or impact on the propeller.
8. Check the fuel in the carburetor. Check to see if there is a high ethanol content present. . If so, purge the fuel system with fresh fuel and see if the engine will start.
9. Check the fuel pressure AT THE CARBURETOR. You should see over 2 PSI. Check fuel lines for inner wall breakdown and wall collapse.
10. Check the Triggers as follows as a defective trigger can cause timing variance:

| Check From: | Check To: | Ohms Reading: | DVA Reading Connected | Disconnected |
|-------------|-----------|---------------|-----------------------|--------------|
| Red         | White     | 300 to 350    | 6 V minimum           | 6 V minimum  |

**WILL NOT STOP (KILL):**

3. Disconnect the White wire from the CD Module.
4. Short the White wire from the CD Module to engine ground. If the engine stops, the problem is in the stop circuit. If the engine continues to run with the White wire shorted to engine ground, replace the defective CD Module.

**WILL NOT CHARGE BATTERY:**

1. Check the resistance of the stator yellow wires as follows:

| Check From    | Check To      | Ohms Reading | DVA Reading Connected | Disconnected |
|---------------|---------------|--------------|-----------------------|--------------|
| Yellow        | Yellow        | 0.22 to 0.24 | 8 V minimum           | 8 V minimum  |
| Yellow (each) | Engine Ground | Open         | -                     | 1 V or less  |

2. Connect a inline ammeter between the regulator/rectifier's Red wire and the positive battery post on the starter solenoid. Connect a battery tester to the battery and start the engine. Increase the engine RPM to approximately 1500-2000 RPM and press the test button on the battery tester. The ammeter should show at least 3 amps of current flow. If not and the stator passes the test above, replace the regulator/rectifier. If the ammeter shows a charge, replace the battery. NOTE: If the problem only shows up at high RPM's, repeat the test while connected to a Dyno or on the water.

**F40 (4 Cyl) 1999**  
**F50 (4 Cyl) 1995-2000**  
**T50 (4 Cyl) 1996-2000**  
**62Y-85540-02-00**

**Service Notes: Please use the Factory recommended spark plug (currently NGK DPR6EA-9) gapped at 0.035".**

**NOTE: Oil Pressure Light Triggers When Oil Pressure Falls Below 4.3 PSI PSI.**

**NO SPARK OR WEAK SPARK:**

1. Disconnect the White stop wire from the Ignition Module. Retest. If the engine's ignition now has spark, the stop circuit has a fault.
2. Check the Stator, Trigger and ignition coil as follows:

| Check From:     | Check To:     | Ohms Reading:                              | DVA Reading Connected | Disconnected  |
|-----------------|---------------|--|-----------------------|---------------|
| Red/White       | White/Black   | 340 to 510                                 | 7 V minimum           | 6 V minimum   |
| Brown           | Blue          | 272 to 408                                 | 140 V minimum         | 190 V minimum |
| Yellow/Black    | Yellow/Black  | 6.5 to 7.3                                 | 7 V minimum           | 10 V minimum  |
| Orange          | Black         |  | 105 V minimum         |               |
| Spark Plug wire | Engine Ground | 3.28K (3280) to 4.92K (4920) (cap removed) |                       |               |

3. Check the resistance of the ignition coil cap between the spark plug wire side and the spark plug side, you should read 3.8K (3800) to 5.7K (5700) ohms.

**NO SPARK ON TWO CYLINDERS:**

1. Swap the ignition coil of the cylinders not firing with one that has fire. If the no fire problem follows the ignition coil, replace the ignition coil.
2. If the ignition coil is good, replace the ECU.

**ENGINE KEEPS FOULING SPARK PLUGS:**

Check the stator DVA output as follows:

| Check From: | Check To: | Idle          | 1500 RPM      | 3500 RPM      |
|-------------|-----------|---------------|---------------|---------------|
| Brown       | Blue      | 140 V minimum | 150 V minimum | 135 V minimum |

1. Check the resistance of the ignition coils. You should read between 3.28K (3280) to 4.92K (4920) ohms for each coil.
2. Check the engine temperature. If the engine is not coming up to operating temperature, it will tend to foul the spark plugs.

**ENGINE WILL NOT ACCELERATE ABOVE APPROXIMATELY 2000 RPM:**

1. Verify the engine is not overheating or if it has low oil pressure and causing the power pack to limit the RPM.
2. Verify the oil pressure is over the minimum 4.3 PSI.
3. Disconnect the Pink wire from the power pack and retest. If the engine now performs correctly, check the overheat sensor and oil pressure sensor mounted on the engine.
4. Check the ignition timing, it should be between approximately 5 degrees BTDC at idle to 35 degrees BTDC (30

degrees BTDC for 1995) at about 3000. If the timing does not advance with RPM, replace the ignition pack.

**HAS SPARK BUT WILL NOT RUN:**

1. Check spark plug for presence of water, indicating a possible cracked block or blown head gasket.
2. Check compression, carburetor, reed blocks and do a cylinder leak down test (remember, a valve not seating properly, stuck rings, improper tappet clearance, damaged piston or a blown head gasket can cause a low reading for a leak down test).
3. Replace the sparkplugs.
4. Check the Timing Belt and verify the cam timing is correct.
5. Make sure the throttle plates are fully closed (the engine will not start if the warm-up lever is raised).
6. Verify the engine is getting fuel to the combustion chamber (make sure there is no water or residue in the carburetor).
7. Check flywheel shear key to make sure it has not sheared due to backfiring or impact on the propeller.
8. Check the fuel in the carburetor. Check to see if there is a high ethanol content present. . If so, purge the fuel system with fresh fuel and see if the engine will start.
9. Check the fuel pressure AT THE CARBURETOR. You should see over 2 PSI. Check fuel lines for inner wall breakdown and wall collapse.
10. Check the Triggers as follows as a defective trigger can cause timing variance:
 

| Check From: | Check To:   | Ohms Reading: | DVA Reading | Connected | Disconnected |
|-------------|-------------|---------------|-------------|-----------|--------------|
| Red/White   | White/Black | 340 to 510    | 7 V minimum |           | 6 V minimum  |

**WILL NOT STOP (KILL):**

3. Disconnect the White wire from the CD Module.
4. Short the White wire from the CD Module to engine ground. If the engine stops, the problem is in the stop circuit. If the engine continues to run with the White wire shorted to engine ground, replace the defective CD Module.

**WILL NOT CHARGE BATTERY:**

1. Check the resistance of the stator Green wires as follows:
 

| Check From   | Check To      | Ohms Reading | DVA Reading | Connected | Disconnected |
|--------------|---------------|--------------|-------------|-----------|--------------|
| Green        | Green         | 1.2 to 1.8   | 8 V minimum |           | 8 V minimum  |
| Green (each) | Engine Ground | Open         | -           |           | 1 V or less  |
2. Connect a inline ammeter between the regulator/rectifier's Red wire and the positive battery post on the starter solenoid. Connect a battery tester to the battery and start the engine. Increase the engine RPM to approximately 1500-2000 RPM and press the test button on the battery tester. The ammeter should show at least 2 amps of current flow. If not and the stator passes the test above, replace the regulator/rectifier. If the ammeter shows a charge, replace the battery. NOTE: If the problem only shows up at high RPM's, repeat the test while connected to a Dyno or on the water.

**F40B (3 Cyl) 2007-2008  
67C-85540-01-00**

Service Notes: Please use the Factory recommended spark plug (currently NGK DPR6EA-9) gapped at 0.035".  
NOTE: Oil Pressure Light Triggers When Oil Pressure Falls Below 2.25 PSI.

**NO SPARK OR WEAK SPARK:**

1. Disconnect the White stop wire from the Ignition Module. Retest. If the engine's ignition now has spark, the stop circuit has a fault.
2. Check the Stator, Trigger and ignition coil as follows:
 

| Check From:      | Check To:     | Ohms Reading:                              | DVA Reading   | Connected | Disconnected |
|------------------|---------------|--|---------------|-----------|--------------|
| Red              | Black         | 340 to 510                                 | 6.9 V minimum |           |              |
| Green/White      | Green/White   | 660 to 710                                 | 190 V minimum |           |              |
| Yellow/Black     | Yellow/Black  | 6.5 to 7.2                                 | 7 V minimum   |           | 10 V minimum |
| Orange           | Black         | 1.8 to 2.4                                 | 120 V minimum |           |              |
| Spark Plug wires | Engine Ground | 2.72K (2720) to 3.68K (3680) (cap removed) |               |           |              |
3. Check the resistance of the ignition coil cap between the spark plug wire side and the spark plug side, you should read 4K-6K ohms.

**Four Stroke**



**NO SPARK ON ONE CYLINDER:**

1. Swap the ignition coil of the cylinder not firing with one that has fire. If the no fire problem follows the ignition coil, replace the ignition coil.
2. If the ignition coil is good, replace the ECU.

**ENGINE KEEPS FOULING SPARK PLUGS:**

1. Check the stator DVA output as follows:
 

| Check From: | Check To:   | Idle          | 1500 RPM      | 3500 RPM |
|-------------|-------------|---------------|---------------|----------|
| Green/White | Green/White | 190 V minimum | 200 V minimum | 200 V    |
2. Check the resistance of the ignition coils. You should read between 2.72K (2720) to 3.68K (3680) ohms (cap removed) for each coil. The spark plug cap should read between 4K and 6 K ohms, through it.
3. Check the engine temperature. If the engine is not coming up to operating temperature, it will tend to foul the spark plugs.
4. Check the engine temperature sensor on a pan of water, as you warm it up. You should get the approximate readings below:
 

| Water Temp: @ 68 degrees | @122 degrees | @158 degrees |
|--------------------------|--------------|--------------|
| 12.49K ohms              | 3.60 K ohms  | 1.75K ohms   |

**ENGINE WILL NOT ACCELERATE ABOVE APPROXIMATELY 2000 RPM:**

1. Verify the engine is not overheating or has low oil pressure and causing the power pack to limit the RPM.
2. Verify the oil pressure is over the minimum 2.25 PSI.
3. Disconnect the Pink wire from the power pack and retest. If the engine now performs correctly, check the overheat sensor and oil pressure sensor mounted on the engine.
4. Check ignition timing, it should be between approximately 3-7 degrees BTDC at idle to 19-21 degrees BTDC at about 3000. If he timing does not advance with RPM, replace the ignition pack.

**HAS SPARK BUT WILL NOT RUN:**

1. Check spark plug for presence of water, indicating a possible cracked block or blown head gasket.
2. Check compression, carburetor, reed blocks and do a cylinder leak down test (remember, a valve not seating properly, stuck rings, improper tappet clearance, damaged piston or a blown head gasket can cause a low reading for a leak down test).
3. Replace the sparkplugs.
4. Check the Timing Belt and verify the cam timing is correct.
5. Make sure the throttle plates are fully closed (the engine will not start if the warm-up lever is raised).
6. Make sure the engine is getting fuel to the combustion chamber (no water or residue in the carburetor).
7. Check flywheel shear key to make sure it has not sheared due to backfiring or impact on the propeller.
8. Check the fuel in the carburetor. Check to see if there is a high ethanol content present. . If so, purge the fuel system with fresh fuel and see if the engine will start.
9. Check the fuel pressure AT THE CARBURETOR. You should see over 2 PSI. Check fuel lines for inner wall breakdown and wall collapse.
10. Check the Trigger as follows as a defective trigger can cause timing variance:
 

| Check From: | Check To: | Ohms Reading: | DVA Reading Connected |
|-------------|-----------|---------------|-----------------------|
| Red         | Black     | 300 to 350    | 6.9 V minimum         |

**WILL NOT STOP (KILL):**

1. Disconnect the White wire from the CD Module.
2. Short the White wire from the CD Module to engine ground. If the engine stops, the problem is in the stop circuit. If the engine continues to run with the White wire shorted to engine ground, replace the defective CD Module.

**WILL NOT CHARGE BATTERY:**

1. Check the resistance of the stator's yellow wires as follows:
 

| Check From    | Check To      | Ohms Reading          | DVA Reading Connected | Disconnected |
|---------------|---------------|-----------------------|-----------------------|--------------|
| Yellow        | Yellow        | 0.9 to 1.1 (9 amp)    | 8 V minimum           |              |
| Yellow        | Yellow        | 0.26 to 0.28 (15 amp) | 8 V minimum           |              |
| Yellow (each) | Engine Ground | Open                  | -                     | 1 V or less  |
2. Connect a inline ammeter between the regulator/rectifier's Red wire and the positive battery post on the starter solenoid. Connect a battery tester to the battery and start the engine. Increase the engine RPM to approximately 1500-2000 RPM and press the test button on the battery tester. The ammeter should show at least 3 amps of

current flow. If not, and the stator passes the test above, replace the regulator/rectifier. If the ammeter shows a charge, replace the battery. NOTE: If the problem only shows up at high RPM's, repeat the test while connected to a Dyno or on the water.

**F50-T50 (4 Cyl) 2001-2004**

**64J-85540-01-00**

**F60 (4 Cyl) 2002-2004**

**T60 (4 Cyl) 2003-2004**

**64W-85540-00-00**

**Service Notes: Please use the Factory recommended spark plug (currently NGK DPR6EA-9) gapped at 0.035".**

**NOTE: Oil Pressure Light Triggers When Oil Pressure Falls Below 7.11 PSI.**

**NO SPARK OR WEAK SPARK:**

1. Disconnect the White stop wire from the Ignition Module. Retest. If the engine's ignition now has spark, the stop circuit has a fault.
2. Check the Stator, Trigger and ignition coil as follows:

| Check From:        | Check To:           | Ohms Reading:              | DVA Reading Connected | Disconnected  |
|--------------------|---------------------|----------------------------|-----------------------|---------------|
| White/Red          | White/Black         | 396 to 594                 | 3.5 V minimum         | 6.3 V minimum |
| Brown              | Blue                | 272 to 408                 | 137 V minimum         | 144 V minimum |
| Black/Orange       | Black               | 0.078-0.106                | 150 V minimum         | 126 V minimum |
| Black/White        | Black               | 0.078-0.106                | 150 V minimum         | 126 V minimum |
| Spark Plug wire #1 | Spark Plug wire # 4 | 3.5K (3500) to 4.7K (4700) |                       |               |
| Spark Plug wire #2 | Spark Plug wire # 3 | 3.5K (3500) to 4.7K (4700) |                       |               |

**NO SPARK ON TWO CYLINDERS:**

1. Swap the input wire ignition coil of the cylinders not firing with one that has fire. If the no fire problem stays on the same cylinders, replace the ignition coil.
2. If the problem moves to the other cylinders, replace the ECU.

**ENGINE KEEPS FOULING SPARK PLUGS:**

1. Check the stator's DVA output as follows:

| Check From: | Check To: | Idle       | 1500 RPM      | 3500 RPM      |
|-------------|-----------|------------|---------------|---------------|
| Brown       | Blue      | 272 to 408 | 137 V minimum | 144 V minimum |

2. Check the resistance of the ignition coils. You should read between 3.5K (3500) to 4.7K (4700) ohms through each coil's high tension leads.
3. Check the engine temperature. If the engine is not coming up to operating temperature, it will tend to foul the spark plugs.
4. Check the engine temperature sensor in a pan of water, as you warm it up. You should get the approximate readings below:

| Water Temp: @ 68 degrees | @122 degrees | @158 degrees |
|--------------------------|--------------|--------------|
| 12.49K ohms              | 3.60 K ohms  | 1.75K ohms   |

**ENGINE WILL NOT ACCELERATE ABOVE APPROXIMATELY 2000 RPM:**

1. Verify the engine is not overheating or has low oil pressure and causing the power pack to limit the RPM.
2. Verify the oil pressure is over the minimum 7.11 PSI.
3. Disconnect the Pink wire from the power pack and retest. If the engine now performs correctly, check the overheat sensor and oil pressure sensor mounted on the engine.
4. Check ignition timing, it should be

| Engine | Idle             | WOT (Wide Open Throttle) |
|--------|------------------|--------------------------|
| F50    | 3-7 degrees BTDC | 30 degrees BTDC          |
| T50    | BTDC             | 35 degrees BTDC          |

NOTE: If the timing does not advance with RPM, replace the ignition pack.

**HAS SPARK BUT WILL NOT RUN:**

1. Check spark plug for presence of water, indicating a possible cracked block or blown head gasket.
2. Check compression, carburetor, reed blocks and do a cylinder leak down test (remember, a valve not seating properly, stuck rings, improper tappet clearance, damaged piston or a blown head gasket can cause a low reading for a leak down test).

**Four Stroke**

3. Replace the sparkplugs.
4. Check the Timing Belt and verify the cam timing is correct.
5. Make sure the throttle plates are fully closed (the engine will not start if the warm-up lever is raised).
6. Verify the engine is getting fuel to the combustion chamber (make sure there is no water or residue in the carburetor).
7. Check flywheel shear key to make sure it has not sheared due to backfiring or impact on the propeller.
8. Check the fuel in the carburetor. Check to see if there is a high ethanol content present. . If so, purge the fuel system with fresh fuel and see if the engine will start.
9. Check the fuel pressure AT THE CARBURETOR. You should see over 2 PSI. Check fuel lines for inner wall breakdown and wall collapse.
10. Check the Triggers as follows as a defective trigger can cause timing variance:

| Check From: | Check To:   | Ohms Reading: | DVA Reading Connected | Disconnected  |
|-------------|-------------|---------------|-----------------------|---------------|
| White/Red   | White/Black | 396 to 594    | 3.5 V minimum         | 6.3 V minimum |

#### WILL NOT STOP (KILL):

1. Disconnect the White wire from the CD Module.
2. Short the White wire from the CD Module to engine ground. If the engine stops, the problem is in the stop circuit. If the engine continues to run with the White wire shorted to engine ground, replace the defective CD Module.

#### WILL NOT CHARGE BATTERY:

1. Check the resistance of the stator yellow wires as follows:

| Check From   | Check To      | Ohms Reading | DVA Reading Connected | Disconnected |
|--------------|---------------|--------------|-----------------------|--------------|
| Green        | Green         | 1.2 to 1.8   | 8 V minimum           | 8 V minimum  |
| Green (each) | Engine Ground | Open         | -                     | 1 V or less  |

2. Connect a inline ammeter between the reg/rect's Red wire and the battery post on the starter solenoid. Start the engine and increase the RPM to about 2000. Connect a 25 Amp load to the battery. The ammeter should show over 2 amps of current flow. If not and the stator passes the test above, replace the regulator/rectifier. If the ammeter shows a charge, replace the battery. NOTE: If the problem only shows up at high RPM's, repeat the test while connected to a Dyno or on the water.

### F50-T50 (4 Cyl Fuel Injected) 2005-2012

6C1-8591A-32-00

### F60-T60 (4 Cyl Fuel Injected) 2005-2012

6C5-8591A-33-00

**Service Notes: Please use the Factory recommended spark plug (currently NGK DPR6EB-9) gapped at 0.035".**

#### NO SPARK OR WEAK SPARK:

1. Disconnect the White stop wire from the Ignition Module. Retest. If the engine's ignition now has spark, the stop circuit has a fault.
2. Check the Stator, Trigger and ignition coil as follows:

| Check From:        | Check To:            | Ohms Reading:                                   | DVA Reading Connected | Disconnected  |
|--------------------|----------------------|---|-----------------------|---------------|
| White/Red          | White/Black          | 396 to 594                                      | 7.2 V minimum         | 7.9 V minimum |
| Black/Red          | Black                | 1.53-2.07                                       | 240 V minimum         | 126 V minimum |
| Black/White        | Black                | 1.53-2.07                                       | 240 V minimum         | 126 V minimum |
| Spark Plug lead #1 | Spark Plug lead #4   | 12.5K (12,500) to 16.91K (16,910) (cap removed) |                       |               |
| Spark Plug lead #2 | Spark Plug lead #3   | 12.5K (12,500) to 16.91K (16,910) (cap removed) |                       |               |
| Spark plug cap     | Spark plug lead side | 1.9K-5K   |                       |               |

#### NO SPARK ON TWO CYLINDERS:

1. Swap the input wire ignition coil of the cylinders not firing with one that has fire. If the no fire problem stays on the same cylinders, replace the ignition coil.
2. Check the resistance of the spark plug cap (removed from the coil) from the high tension side to the spark plug side. You should read between 1.9K to 5 K ohms.
3. If the problem moves to the other cylinders, replace the ECU.

#### ENGINE KEEPS FOULING SPARK PLUGS:

1. Check the resistance of the ignition coils. You should read between 12.5K (12,500) to 16.91K (16,910) ohms for each coil and

2. Check the engine temperature. A cold engine will tend to foul the spark plugs.
3. Check the engine temperature sensor in a pan of water, as you warm it up. You should get the approximate readings below:

| Water Temp: @ 68 degrees | @140 degrees | @212 degrees |
|--------------------------|--------------|--------------|
| 2.439K ohms              | 0.589 K ohms | 0.193K ohms  |

4. Check the resistance of the fuel injectors. You should read between 11-13 ohms.

**ENGINE WILL NOT ACCELERATE ABOVE APPROXIMATELY 2000 RPM:**

1. Verify the engine is not overheating or has low oil pressure and causing the power pack to limit the RPM.
2. Verify the oil pressure is over the minimum PSI (varies with engine RPM).
3. Disconnect the Pink wire from the power pack and retest. If the engine now performs correctly, check the overheat sensor and oil pressure sensor mounted on the engine.
4. Check the Throttle Position Sensor (TPS) resistance from idle to WOT. You should have a smooth change in resistance from the idle setting through WOT. Idle DC voltage should be between 0.8-1.2 V.
5. Check ignition timing, it should be close to the following:

| Engine | Idle            | WOT (Wide Open Throttle) |
|--------|-----------------|--------------------------|
| F50    | 10 degrees ATDC | 25 degrees BTDC          |

NOTE: If the timing does not advance with RPM, replace the ECU.

| 6. Check From: | Check To:   | Idle          | 1500 RPM       | 3500 RPM     |
|----------------|-------------|---------------|----------------|--------------|
| White/Red      | White/Black | 7.2 V minimum | 20.7 V minimum | 32 V minimum |

**HAS SPARK BUT WILL NOT RUN:**

1. Check spark plug for presence of water, indicating a possible cracked block or blown head gasket.
2. Check compression, carburetor, reed blocks and do a cylinder leak down test (remember, a valve not seating properly, stuck rings, improper tappet clearance, damaged piston or a blown head gasket can cause a low reading for a leak down test).
3. Replace the sparkplugs.
4. Check the Timing Belt and verify the cam timing is correct.
5. Check fuel and make sure it is still good. Also check for a high level of ethanol in the gas.
6. Verify the engine is has the correct fuel pressure into and out of the fuel pump.
7. Make sure the fuel injectors are not stuck open or closed.
8. Make sure the fuel injectors are opening and closing.
9. Check flywheel shear key to make sure it has not sheared due to backfiring or impact on the propeller.
10. Check fuel lines for inner wall breakdown and wall collapse.
11. Check the Pulsar coil resistance and air gap. You should read from White/Red to White/Black, 396 to 594 ohms with a 0.020-0.040 inch air gap.
12. Check timing at cranking, you should have approximately 10 degrees ATDC (After Top Dead Center).
13. Check the Triggers as follows (a defective trigger can cause timing variance):

| Check From: | Check To:   | Ohms Reading: | DVA Reading Connected | Disconnected  |
|-------------|-------------|---------------|-----------------------|---------------|
| Red/White   | White/Black | 340 to 510    | 7.2 V minimum         | 7.9 V minimum |

**WILL NOT STOP (KILL):**

1. Disconnect the White wire from the CD Module.
2. Short the White wire from the CD Module to engine ground. If the engine stops, the problem is in the stop circuit. If the engine continues to run with the White wire shorted to engine ground, replace the defective CD Module.

**WILL NOT CHARGE BATTERY:**

1. Check the resistance of the stator yellow wires as follows:

| Check From   | Check To      | Ohms Reading | DVA Reading Connected | Disconnected   |
|--------------|---------------|--------------|-----------------------|----------------|
| Green        | Green         | 0.52 to 0.63 | 8 V minimum           | 13.2 V minimum |
| Green (each) | Engine Ground | Open         | -                     | 1 V or less    |

2. Connect a inline ammeter between the regulator/rectifier's Red wire and the positive battery post on the starter solenoid. Connect a battery tester to the battery and start the engine. Increase the engine RPM to approximately 1500-2000 RPM and press the test button on the battery tester. The ammeter should show at least 2 amps of current flow. If not and the stator passes the test above, replace the regulator/rectifier. If the ammeter shows a

**Four Stroke**

## **Appendix**

### **(DVA) PEAK READING VOLTAGE AND RESISTANCE CHARTS**

NOTICE: These charts were compiled using the CDI 511-9773NL Peak Adapter with a shielded Digital Multimeter.

(NOTE) The resistance readings are given for a room temperature of 68°F. Higher temperatures will cause a slightly higher resistance reading.

DVA readings should always be taken with everything connected with the exception of the stop circuit.

The CDI peak reading voltage adapter is specifically designed to work with shielded Digital Multimeters. This adapter will simplify the testing of electronic ignition systems, stators, sensors and charging systems. The DVA readings will be approximately the same as any other DVA meter and the specifications listed in the service manuals can be followed without problems (Hopefully a little easier to you).

The CDI piercing probe set (511-9770) and the pack load resistor (511-9775) are highly recommended for use with this adapter.

#### **INSTRUCTIONS**

1. Plug the adapter into the shielded Digital Multimeter with the (+) rib side pin in the (V, Ohms) jack and the other pin in the (COM) jack.
2. Set the digital voltmeter to DC Volts (the purpose of the adapter is to convert and store the voltage so that it can be read by a meter).
3. Connect the probes to the component to be measured.

(NOTE) The adapter will automatically compensate for polarity and all readings will be peak voltage.

See the following pages for readings of Chrysler, Force, Mercury, OMC (Johnson/Evinrude), OMC Sea Drive and Yamaha engines. Other ignitions can be tested using test results given by the manufacturer of the equipment or by comparing a known good system to a suspect one. Please forward any additional readings you would like to have included in future printings.

“Design, Quality, Reliability, Service” · Tech Support 866-423-4832 · Fax 256-772-5701 · [www.cdielelectronics.com](http://www.cdielelectronics.com)



**Appendix**

**Chrysler/Force  
DVA (Peak Reading) Voltage and Resistance Chart**

| HP  | Year          | Model or Serial#      | Ignition Part Number                       | Stator Ohms                   |                   |                             |                 | DVA          |              | Trigger                                       |          |       | Ignition Coil Ohms |                            |
|-----|---------------|-----------------------|--|-------------------------------|-------------------|-----------------------------|-----------------|--------------|--------------|---|----------|-------|--------------------|----------------------------|
|     |               |                       |  | Read                          |                   | Low Spd                     | High Spd        | Low Spd      | High Spd     | Read  | Ohms     | DVA   | Pri                | Sec                        |
|     |               |                       |  | Low Spd                       | High Spd          |                             |                 |              |              |   |          |       |                    |                            |
| 7.5 | 1972          | B0C/B1D/<br>H0C/H1D   | 525475<br>116-5475*                        | Blue to Blue                  |                   | 680-900<br>250-350*         |                 | 180-400V     |              | Org to Grn<br>Red to Wht/Grn                  | 45-55    | 0.5V+ | N/A                | 125-140<br>225-325*        |
| 7.5 | 1977          | B0C/B1C/<br>H0C/H1C   | 525475<br>116-5475*                        | Blue to Blue                  |                   | 680-900<br>250-350*         |                 | 180-400V     |              | Org to Grn<br>Red to Wht/Grn                  | 45-55    | 0.5V+ | N/A                | 125-140<br>225-325*        |
| 7.5 | 1979-<br>1984 | All Models            | 525475<br>116-5475*                        | Blue to Blue                  |                   | 680-900<br>250-350*         |                 | 180-400V     |              | Org to Grn<br>Red to Wht/Grn                  | 45-55    | 0.5V+ | N/A                | 125-140<br>225-325*        |
| 8   | 1982          | 82H8J-<br>87H8A       | 525475<br>116-5475*                        | Blue to Blue                  |                   | 680-900<br>250-350*         |                 | 180-400V     |              | Org to Grn<br>Red to Wht/Grn                  | 45-55    | 0.5V+ | N/A                | 125-140<br>225-325*        |
| 9.9 | 1979-<br>1984 | A, B                  | 510301<br>116-0301*                        | Blue to Yellow                |                   | 680-900<br>250-350*         |                 | 180-400V     |              | Org to Grn<br>Red to Wht/Grn                  | 45-55    | 0.5V+ | 0.2-<br>1.0        | 800-1100                   |
| 10  | 1976-<br>1978 | W/CD &<br>Alternator  | 510301<br>116-0301*                        | Blue to Yellow                |                   | 680-900<br>250-350*         |                 | 180-400V     |              | Org to Grn<br>Red to Wht/Grn                  | 45-55    | 0.5V+ | 0.2-<br>1.0        | 800-1100                   |
| 12  | 1979          | W/CD &<br>Alternator  | 510301<br>116-0301*                        | Blue to Yellow                |                   | 680-900<br>250-350*         |                 | 180-400V     |              | Org to Grn<br>Red to Wht/Grn                  | 45-55    | 0.5V+ | 0.2-<br>1.0        | 800-1100                   |
| 15  | 1976-<br>1984 | W/CD &<br>Alternator  | 510301<br>116-0301*                        | Blue to Yellow                |                   | 680-900<br>250-350*         |                 | 180-400V     |              | Org to Grn<br>Red to Wht/Grn                  | 45-55    | 0.5V+ | 0.2-<br>1.0        | 800-1100                   |
| 20  | 1979-<br>1981 | W/CD &<br>Alternator  | 529301<br>116-9301*                        | Yellow to<br>Gnd              | Blue to<br>Gnd    | 1950-<br>2400               | 50-70           | 45-55        | 25-<br>100 V | Org to Grn<br>Red to Wht/Grn                  | 45-55    | 0.5V+ | 0.2-<br>1.0        | 800-1100                   |
| 25  | 1983-<br>1984 | W/CD &<br>Alternator  | 529301<br>116-9301*                        | Yellow to<br>Gnd              | Blue to<br>Gnd    | 1950-<br>2400               | 50-70           | 45-55        | 25-<br>100 V | Org to Grn<br>Red to Wht/Grn                  | 45-55    | 0.5V+ | 0.2-<br>1.0        | 800-1100                   |
| 30  | 1979-<br>1982 | W/CD &<br>Alternator  | 529301<br>116-9301*                        | Yellow to<br>Gnd              | Blue to<br>Gnd    | 1950-<br>2400               | 50-70           | 45-55        | 25-<br>100 V | Org to Grn<br>Red to Wht/Grn                  | 45-55    | 0.5V+ | 0.2-<br>1.0        | 800-1100                   |
| 35  | 1978-<br>1984 | W/CD &<br>Alternator  | 529301<br>116-9301*                        | Yellow to<br>Gnd              | Blue to<br>Gnd    | 1950-<br>2400               | 50-70           | 45-55        | 25-<br>100 V | Org to Grn<br>Red to Wht/Grn                  | 45-55    | 0.5V+ | 0.2-<br>1.0        | 800-1100                   |
| 35  | 1987-<br>1991 | All Models            | 529301<br>116-9301*                        | Yellow to<br>Gnd              | Blue to<br>Gnd    | 1950-<br>2400               | 50-70           | 45-55        | 25-<br>100 V | Org to Grn<br>Red to Wht/Grn (a)              | 45-55    | 0.5V+ | N/A                | 125-140<br>225-325*        |
| 40  | 1992-<br>1995 | OE000001-<br>OE138599 | 18495<br>114-4952*                         | Blue to<br>Blue/Wht           | Red to<br>Red/Wht | 3250-3650<br>2200-<br>2400* | 75-90<br>28-32* | 180-<br>400V | 25-<br>100V  | Wht/Blk to Brown,<br>White & Purple           | 800-1400 | 4V+   | 0.2-<br>1.0        | 800-1100                   |
| 40  | 1996-<br>1999 | OE138600-<br>OE369299 | 827509<br>114-7509*                        | Green/White to<br>White/Green |                   | 500-700<br>400-600*         |                 | 180-400V     |              | Eng Gnd to Wht/<br>Blk at CDM                 | Open     | 1V+   | N/A                | 800-1100                   |
| 50  | 1988          | A, B, C               | 658475<br>116-8475*                        | Blue to Blue                  |                   | 680-900<br>250-350*         |                 | 180-400V     |              | Org to Grn<br>Red to Wht/Grn (a)              | 45-55    | 0.5V+ | N/A                | 125-140<br>225-325*        |
| 50  | 1988          | D                     | 658301<br>116-8301*                        | Blue to Yellow (b)            |                   | 680-900<br>250-350*         |                 | 180-400V     |              | Org to Grn<br>Red to Wht/Grn (a)              | 45-55    | 0.5V+ | N/A                | 125-140<br>225-325*        |
| 50  | 1989-<br>1992 | All Models            | 658301<br>116-8301*                        | Blue to Yellow (b)            |                   | 680-900<br>250-350*         |                 | 180-400V     |              | Org to Grn<br>Red to Wht/Grn (a)              | 45-55    | 0.5V+ | N/A                | 125-140<br>225-325*        |
| 50  | 1992-<br>1995 | OE000001-<br>OE138599 | 18495<br>114-4952*                         | Blue to<br>Blue/Wht           | Red to<br>Red/Wht | 3250-3650<br>2200-<br>2400* | 75-90<br>28-32* | 180-<br>400V | 25-<br>100V  | Wht/Blk to Brown,<br>White & Purple           | 800-1400 | 4V+   | 0.2-<br>1.0        | 800-1100                   |
| 50  | 1996-<br>1999 | OE138600-<br>OE369299 | 827509<br>114-7509*                        | Green/White to<br>White/Green |                   | 500-700<br>400-600*         |                 | 180-400V     |              | Eng Gnd to Wht/<br>Blk at CDM                 | Open     | 1V+   | N/A                | 800-1100                   |
| 55  | 1977-<br>1980 | W/Magna-<br>power II  | 474301-1                                   | T1 & T4 to Eng Gnd            |                   | Not Applicable              |                 | 180-400V     |              | Between Terminals                             | Open     | 0.5V+ | 0.2-<br>1.0        | 200-2000                   |
| 55  | 1981-<br>1983 | All Models            | 475301<br>116-5301*                        | Blue to Yellow                |                   | 680-900<br>250-350*         |                 | 180-400V     |              | Org to Grn<br>Red to Wht/Grn                  | 45-55    | 0.5V+ | 0.2-<br>1.0        | 800-1100                   |
| 60  | 1984          | All Models            | 475301<br>116-5301*                        | Blue to Yellow                |                   | 680-900<br>250-350*         |                 | 180-400V     |              | Org to Grn<br>Red to Wht/Grn                  | 45-55    | 0.5V+ | 0.2-<br>1.0        | 800-1100                   |
| 60  | 1985          | All Models            | 475301<br>116-5301*                        | Blue to Yellow (b)            |                   | 680-900<br>250-350*         |                 | 180-400V     |              | Org to Grn<br>Red to Wht/Grn (a)              | 45-55    | 0.5V+ | 0.2-<br>1.0        | 800-1100                   |
| 65  | 1977-<br>1978 | W/Magna-<br>power II  | 474301-1                                   | T1 & T4 to Eng Gnd            |                   | Not Applicable              |                 | 170-270 V    |              | Between Terminals                             | Open     | 0.5V+ | 0.2-<br>1.0        | 200-2000                   |
| 70  | 1991-<br>1992 | OE000001-<br>OE009499 | 332-7778<br>114-7778*                      | Blue to<br>Eng Gnd            | Red to<br>Eng Gnd | 3250-3650<br>2000-<br>2400* | 75-90<br>28-32* | 180-<br>400V | 25-<br>100V  | Wht/Blk to Brown,<br>White & Purple           | 800-1400 | 4V+   | 0.2-<br>1.0        | 800-1100                   |
| 70  | 1993-<br>1995 | OE009500-<br>OE138599 | 18495<br>114-4953*                         | Blue to<br>Eng Gnd            | Red to<br>Eng Gnd | 3250-3650<br>2000-<br>2400* | 75-90<br>28-32* | 180-<br>400V | 25-<br>100V  | Wht/Blk to Brown,<br>White & Purple           | 800-1400 | 4V+   | 0.2-<br>1.0        | 800-1100                   |
| 75  | 1996-<br>1999 | OE138600-<br>OE369299 | 827509<br>114-7509*                        | Green/White to<br>White/Green |                   | 500-700<br>400-600*         |                 | 180-400V     |              | Eng Gnd to Wht/<br>Blk, Wht/Yel, Blue/<br>Wht | Open     | 1V+   | N/A                | 900-1100<br>2100-<br>2400* |
| 80  | 1983-<br>1984 | W/CD &<br>Alternator  | 475301<br>116-5301*                        | Blue to Yellow                |                   | 680-900<br>250-350*         |                 | 180-400V     |              | Org to Grn<br>Red to Wht/Grn                  | 45-55    | 0.5V+ | 0.2-<br>1.0        | 800-1100                   |
| 85  | 1983          | 856XL                 | 475301<br>116-5301*                        | Blue to Yellow (b)            |                   | 680-900<br>250-350*         |                 | 180-400V     |              | Org to Grn<br>Red to Wht/Grn (a)              | 45-55    | 0.5V+ | 0.2-<br>1.0        | 800-1100                   |
| 85  | 1984-<br>1989 | All Models            | 475301<br>658301<br>116-5301*<br>116-8301* | Blue to Yellow (b)            |                   | 680-900<br>250-350*         |                 | 180-400V     |              | Org to Grn<br>Red to Wht/Grn (a)              | 45-55    | 0.5V+ | 0.2-<br>1.0        | 200-2000                   |

**Blk = Black    Grn = Green    Pur = Purple    Yel = Yellow    Eng Gnd = Engine Ground    N/A = Not Applicable    Pri = Primary**  
**Brn = Brown    Org = Orange    Wht = White    Gnd = Engine Ground    COMM = Commercial    Sec = Secondary**

\* Indicates a part manufactured by CDI Electronics  
 a) Some units use a White/Orange trigger lead instead of a Green wire.  
 b) Some Stator leads are Brown/Blue stripe instead of Blue and Brown/Yellow stripe instead of Yellow.

Appendix

# Appendix

## Chrysler/Force DVA (Peak Reading) Voltage and Resistance Chart

| HP                | Year      | Model or Serial#      | Ignition Part Number                        | Stator                                |                     |                                |                 |           |          | Trigger  |          |        | Ignition Coil |                        |
|-------------------|-----------|-----------------------|---|---------------------------------------|---------------------|--------------------------------|-----------------|-----------|----------|--|----------|--------|---------------|------------------------|
|                   |           |                       |   | Read                                  |                     | Ohms                           |                 | DVA       |          | Read   | Ohms     | DVA    | Ohms          |                        |
|                   |           |                       |   | Low Spd                               | High Spd            | Low Spd                        | High Spd        | Low Spd   | High Spd |  |          |        | Pri           | Sec                    |
| 90                | 1983-1984 |                       | 475301<br>116-5301*                         | Blue to Yellow (b)                    |                     | 680-900<br>250-350*            |                 | 180-400 V |          | Org to Green<br>Red to Wht/<br>Grn (a)                 | 45-55    | 0.5 V+ | 0.2-1.0       | 200-2000               |
| 90                | 1990      | All Models            | 658301<br>116-8301*                         | Blue to Yellow (b)                    |                     | 680-900<br>250-350*            |                 | 180-400 V |          | Org to Green<br>Red to Wht/<br>Grn (a)                 | 45-55    | 0.5 V+ | 0.2-1.0       | 200-2000               |
| 90                | 1991      | B & D                 | 332-7778<br>114-7778                        | Blue to Eng Gnd                       | Red to Eng Gnd      | 3250-3650<br>400-520           | 75-90<br>28-32* | 180-400 V | 25-100 V | Wht/Blk to Brown,<br>White & Purple                    | 800-1400 | 4 V+   | 0.2-1.0       | 200-2000               |
| 90                | 1991      | A, C & E              | 658301<br>116-8301*                         | Blue to Yellow (b)                    |                     | 680-900<br>250-350*            |                 | 180-400 V |          | Org to Green<br>Red to Wht/Grn (a)                     | 45-55    | 0.5 V+ | 0.2-1.0       | 200-2000               |
| 90                | 1991-1995 | OE000001-<br>OE138599 | 332-7778<br>18495<br>114-7778*<br>114-4953* | Blue to Eng Gnd                       | Red to Eng Gnd      | 3250-3650<br>2000-2400*        | 75-90<br>28-32* | 180-400V  | 25-100V  | Wht/Blk to Brown,<br>White & Purple                    | 800-1400 | 4V+    | 0.2-1.0       | 800-1100               |
| 90                | 1996-1999 | OE138600-<br>OE369299 | 827509<br>114-7509*                         | Green/White to<br>White/Green         |                     | 500-700<br>400-600*            |                 | 180-400V  |          | Eng Gnd to Wht/<br>Blk, Wht/Yel, Blue/<br>Wht          | Open     | 1V+    | N/A           | 900-1100<br>2100-2400* |
| 105               | 1976      | BD/BE/HA/<br>HD/HE    | 474301-1                                    | T1 & T4 to Eng Gnd                    |                     | Not Applicable                 |                 | 170-270 V |          | Between Terminals                                      | Open     | 0.5V+  | 0.2-1.0       | 200-2000               |
| 115               | 1983-1984 | W/CD &<br>Alternator  | 475301<br>116-5301*                         | Blue to Yellow                        |                     | 680-900<br>250-350*            |                 | 180-400V  |          | Org to Grn<br>Red to Wht/Grn                           | 45-55    | 0.5V+  | 0.2-1.0       | 800-1100               |
| 120               | 1976      | BD/BE/<br>HD/HE       | 474301-1                                    | T1 & T4 to Eng Gnd                    |                     | Not Applicable                 |                 | 180-400V  |          | Between Terminals                                      | Open     | 0.5V+  | 0.2-1.0       | 200-2000               |
| 120               | 1990-1994 | 90A, 91C              | 658301<br>116-8301*                         | Blue to Yellow (b)                    |                     | 680-900<br>250-350*            |                 | 180-400V  |          | Org to Grn<br>Red to Wht/Grn (a)                       | 45-55    | 0.5V+  | 0.2-1.0       | 200-2000               |
| 120               | 1996-1999 | OE138600-<br>OE369299 | 827509<br>114-7509*                         | Green/White to<br>White/Green         |                     | 500-700<br>400-600*            |                 | 180-400V  |          | Eng Gnd to Wht/<br>Blk, Wht/Yel, Blue/<br>Wht, Brn/Wht | Open     | 1V+    | N/A           | 900-1100<br>2100-2400* |
| 120<br>L<br>Drive | 1990      | A, B, C               | 658301<br>116-8301*                         | Blue to Yellow (b)                    |                     | 680-900<br>250-350*            |                 | 180-400V  |          | Org to Grn<br>Red to Wht/Grn (a)                       | 45-55    | 0.5V+  | 0.2-1.0       | 200-2000               |
| 120               | 1991-1995 | OE006551-<br>OE138599 | 332-5772<br>114-5772*                       | Blue to Blue/Wht (LS)                 | Red to Red/Wht (HS) | 3250-3650<br>2000-2400*        | 75-90<br>28-32* | 180-400V  | 25-100V  | Brown to Wht/Blk<br>Purple to<br>White                 | 800-1400 | 4V+    | 0.2-1.0       | 800-1100               |
| 125               | 1981-1982 | W/CD &<br>Alternator  | 475301<br>116-5301*                         | Blue to Yellow                        |                     | 680-900<br>250-350*            |                 | 180-400V  |          | Org to Grn<br>Red to Wht/Grn                           | 45-55    | 0.5V+  | 0.2-1.0       | 800-1100               |
| 125               | 1983-1989 | All Models            | 475301<br>658301<br>116-5301*<br>116-8301*  | Blue to Yellow (b)                    |                     | 680-900<br>300-400*            |                 | 180-400V  |          | Org to Grn<br>Red to Wht/Grn (a)                       | 45-55    | 0.5V+  | 0.2-1.0       | 800-1100               |
| 135               | 1976      | BD/BE/<br>HD/HE       | 474301-1                                    | T1 & T4 to Eng Gnd                    |                     | Not Applicable                 |                 | 170-270 V |          | Between Terminals                                      | Open     | 0.5V+  | 0.2-1.0       | 200-2000               |
| 150               | 1989-1991 | 89A, 90C,<br>90D, 91A | 658301<br>116-8301*                         | Blue to Yellow (b)                    |                     | 680-900<br>250-350*            |                 | 180-400V  |          | Org to Grn<br>Red to Wht/Grn (a)                       | 45-55    | 0.5V+  | 0.2-1.0       | 800-1100               |
| 150               | 1991-1993 | OE000001-<br>OE093699 | 332-<br>817323<br>116-7323*                 | Blue to Eng Gnd                       |                     | Not Applicable<br>12V Inverter |                 | 225-300V  |          | Wht/Blk to Brn,<br>Blk, Wht, Pur<br>& Yel              | 800-1400 | 4 V+   | 0.2-1.0       | 800-1100               |
| 150               | 1991-1993 | OE000001-<br>OE093699 | 332-<br>817323<br>116-7323*                 | Blue to Eng Gnd<br>174-4796K 1 Stator |                     | 70-90                          |                 | 160-400 V |          | Wht/Blk to Brn,<br>Blk, Wht, Pur<br>& Yel              | 800-1400 | 4 V+   | 0.2-1.0       | 800-1100               |

Blk = Black    Grn = Green    Pur = Purple    Yel = Yellow    Eng Gnd = Engine Ground    N/A = Not Applicable    Pri = Primary  
 Brn = Brown    Org = Orange    Wht = White    Gnd = Engine Ground    COMM = Commercial    Sec = Secondary

- \* Indicates a part manufactured by CDI Electronics
- a) Some units use a White/Orange trigger lead instead of a Green wire.
- b) Some Stator leads are Brown/Blue stripe instead of Blue and Brown/Yellow stripe instead of Yellow.

### Color Code Cross Reference

| FUNCTION | OLD                | NEW                 | FUNCTION            | OLD    | NEW          |
|----------|--------------------|---------------------|---------------------|--------|--------------|
| Trigger  | Orange             | White/Orange Stripe | Pack Output to Coil | Orange | Orange/Blue  |
| Trigger  | Green              | White/Yellow Stripe | Pack Output to Coil | Red    | Blue/Red     |
| Trigger  | Red                | White/Red Stripe    | Ignition Coil       | White  | Orange/Blue  |
| Trigger  | White/Green Stripe | White/Green Stripe  | Stop Circuit        | White  | Black/Yellow |
| Stator   | Blue               | Brown/Blue Stripe   |                     |        |              |
| Stator   | Yellow             | Brown/Yellow Stripe |                     |        |              |

# Appendix

## Johnson/Evinrude DVA (Peak Reading) Voltage and Resistance Chart

| HP                         | Year      | Model                                    | Ignition Part Number   | Stator   |  |   | Power Coil                |                   |                | Trigger  |                      |                               |
|----------------------------|-----------|--|--|--|--|---|---------------------------|-------------------|----------------|--|----------------------|-------------------------------|
|                            |           |  |  | Charge Coil Read   | Charge Coil Ohms                           | Charge Coil DVA                             | Power Coil Read           | Power Coil Ohms   | Power Coil DVA | Trigger Read   | Trigger Ohms         | Trigger DVA                   |
| 4-60                       | 1978-1984 | CD2                                      | 582453<br>582474<br>113-2453*<br>113-2474*   | Brown to Brown/<br>Yellow                                  | 500-650                                    | 150-400V                                    | N/A                       | N/A               | N/A            | White/Black to<br>Black/White  | 15-50                | 0.6V+                         |
| 4-60                       | 1985-1988 | CD2                                      | 582285<br>583241<br>113-2285*<br>113-3241*   | Brown to Brown/<br>Yellow                                  | 550-650<br>500-650*                        | 150-400V                                    | N/A                       | N/A               | N/A            | White/Black to<br>Black/White  | 15-50                | 0.6V+                         |
| 4-55                       | 1989-1993 | CD2 - USL                                | 584488<br>584489<br>113-4488<br>113-4489   | Brown to Brown/<br>Yellow                                  | 535-685<br>500-650*                        | 150-400V                                    | N/A                       | N/A               | N/A            | N/A  | N/A                  | N/A                           |
| 4-55                       | 1989-1993 | CDI USL<br>Replacement                   | 584488<br>584489<br>113-4488*<br>113-4489*   | Brown to Brown/<br>Yellow                                  | 500-650                                    | 150-400V                                    | N/A                       | N/A               | N/A            | White/Black to<br>Black/White  | 15-50                | 0.6V+                         |
| 5-50                       | 1992-2006 | CD2<br>W/SLOW                            | 584767<br>584783<br>113-4767*<br>113-4783*   | Brown to Brown/<br>Yellow                                  | 500-650                                    | 150-400V                                    | N/A                       | N/A               | N/A            | White/Black to<br>Black/White  | 15-50                | 0.6V+                         |
| 25-50                      | 1992-2005 | CD2<br>W/SLOW                            | 585316<br>113-5316*  | Brown to Brown/<br>Yellow                                  | 650-850                                    | 150-400V                                    | Orange to<br>Orange/Black | 450-550<br>45-55* | 11-22V         | White to Blue and<br>Green   | 15-50                | 100-<br>400V                  |
| 50-55                      | 1971-1977 | Power Pack 2                             | 581397<br>113-1397*  | Brown to Engine<br>Ground                                  | 650-850                                    | 150-400V                                    | N/A                       | N/A               | N/A            | White/Black to<br>Black/White  | 10-20                | 0.6V+                         |
| 25-35<br>Electric<br>Start | 1995-1997 | CD3 OPTICAL                              | 584823<br>586472<br>586504   | Brown to Brown/<br>Yellow                                  | 720-880<br>650-850*                        | 150-400V                                    | Orange to<br>Orange/Black | 52-62             | 11-22V         | N/A  | N/A                  | N/A                           |
| 25-35<br>Manual<br>Start   | 1995-1997 | CD3 OPTICAL                              | 584823<br>586472<br>586504   | Brown to Brown/<br>Yellow                                  | 1010-<br>1230<br>650-850*                  | 150-400V                                    | Orange to<br>Orange/Black | 76-92             | 11-22V         | N/A  | N/A                  | N/A                           |
| 40-70                      | 1993-2001 | CD3<br>Looper W/<br>SLOW &<br>Quickstart | 585129<br>113-4808*  | Brown to Brown/<br>Yellow                                  | 450-550<br>650-850*                        | 150-400V                                    | Orange to<br>Orange/Black | 450-550<br>45-55* | 11-22V         | White to Blue/<br>Purple/Green<br><br>White to Black/<br>White   | Open<br><br>400-500  | 100-<br>400V<br>6-12V         |
| 60-75                      | 1972-1973 | Power Pack 3                             | 581726<br>113-1726*  | Brown to Brown/<br>Yellow                                  | 870-930<br>650-850*                        | 150-400V                                    | N/A                       | N/A               | N/A            | Black/White to<br>White/Blacks   | 10-20<br>35-55*      | 0.6V+                         |
| 60-75                      | 1974-1978 | Power Pack 3                             | 581726<br>113-1726*  | Brown to Brown/<br>Yellow                                  | 555-705<br>650-850*                        | 150-400V                                    | N/A                       | N/A               | N/A            | Black/White to<br>White/Blacks   | 10-20<br>35-55*      | 0.6V+                         |
| 60-75                      | 1979-1984 | CD3                                      | 582115<br>582138<br>113-2115*<br>113-2138*   | Brown to Brown/<br>Yellow                                  | 360-440<br>(9 Amp)<br>750-950<br>(12 Amp)  | 150-400V                                    | N/A                       | N/A               | N/A            | White to Blue/<br>Purple/Green   | 9-21<br>38-42*       | 0.6V+                         |
| 60-75                      | 1985-1988 | CD3                                      | 582115<br>113-2115*  | Brown to Brown/<br>Yellow                                  | 535-585<br>530-630*                        | 150-400V                                    | N/A                       | N/A               | N/A            | White to Blue/<br>Purple/Green   | 9-21<br>38-42*       | 0.6V+                         |
| 60-70                      | 1989-1992 | CD3<br>W/SLOW                            | 583748<br>113-3748*  | Brown to Brown/<br>Yellow                                  | 455-505<br>650-850*                        | 150-400V                                    | Orange to<br>Orange/Black | 450-550<br>45-55* | 11-22V         | White to Blue/<br>Purple/Green   | 38-42                | 100-<br>400V                  |
| 65<br>Comm                 | 1984-1988 | CD3                                      | 582556<br>583122<br>113-2556*<br>113-3122*   | Brown to Brown/<br>Yellow                                  | 450-550<br>500-650*                        | 150-400V                                    | N/A                       | N/A               | N/A            | White to Blue/<br>Purple/Green   | 38-42                | 0.6V+                         |
| 65                         | 1996-2001 | CD3<br>W/SLOW                            | 585274<br>113-5274*  | Brown to Brown/<br>Yellow                                  | 450-550                                    | 150-400V                                    | Orange to<br>Orange/Black | 450-550<br>45-55* | 11-22V         | White to Blue/<br>Purple/Green   | 38-42                | 100-<br>400V                  |
| 65-115                     | 1989-1998 | CD4                                      | 584028<br>584030<br>113-4028*<br>113-4030*   | Brown to Brown/<br>Yellow                                  | 450-550                                    | 150-400V                                    | N/A                       | N/A               | N/A            | White to Blue/<br>Purple/Green/Pink  | 11-45                | 100-<br>400V                  |
| 85-140                     | 1973-1977 | Power Pack 4                             | 581731<br>113-1731*  | Brown to Brown/<br>Yellow                                  | 400-600                                    | 150-400V                                    | N/A                       | N/A               | N/A            | #1 to #3 and<br>#2 to #4   | 10-20<br>30-40*      | 0.6V+                         |
| 85-140                     | 1978-1987 | CD2/4<br>Dual Packs                      | 582125<br>582684<br>582704<br>582811<br>583110<br>583116<br>113-2125*<br>113-2684*<br>113-2704*<br>113-2811*<br>113-3110*<br>113-3116* | Brown to Brown/<br>Yellow<br><br>Brown to Brown/<br>Yellow | 9 AMP<br>450-550<br><br>35 AMP<br>950-1100 | 9 AMP<br>150-400V<br><br>35 AMP<br>150-400V | N/A<br><br>N/A            | N/A<br><br>N/A    | N/A<br><br>N/A | White to Blue and<br>Green<br><br>White/Black to<br>Blue/White and<br>Green/White                                    | 11-45                | 0.6V+                         |
| 88-140                     | 1985-1988 | CD4                                      | 583072<br>583101<br>113-3072*<br>113-3101*   | Brown to Brown/<br>Yellow                                  | 450-550                                    | 150-400V                                    | N/A                       | N/A               | N/A            | White to Blue/<br>Purple/Green/Pink  | 11-45                | 0.6V+                         |
| 90-115                     | 1995-2006 | CD4<br>OPTICAL                           | 586292<br>113-6292*  | Brown to Brown/<br>Yellow (or<br>Brown/White)              | 900-1200                                   | 150-400V                                    | Orange to<br>Orange/Black | 50-60             | 11-22V         | Orange/Red to<br>Eng Gnd<br><br>Black/Orange to<br>Eng Gnd   | N/A                  | 10.5-12<br>VDC<br>8-10<br>VDC |
| 120-140                    | 1988-2001 | CD4<br>w/Quick-Start                     | 584041<br>113-4041*  | Brown to Brown/<br>Yellow                                  | 9 AMP<br>450-550<br>35 AMP<br>950-1100     | 9 AMP<br>150-400V<br>35 AMP<br>150-400V     | Orange to<br>Orange/Black | 93-100<br>45-55*  | 11-22V         | White to Blue/<br>Purple/Green/Pink<br>White to Blue/<br>White, Purple/<br>White, Green/<br>White and Pink/<br>White | 35-55<br><br>120-130 | 0.6V+<br><br>1.5V+            |

Blk = Black Grn = Green Pur = Purple Yel = Yellow Eng Gnd = Engine Ground N/A = Not Applicable Pri = Primary  
 Brn = Brown Org = Orange Wht = White Gnd = Engine Ground COMM = Commercial Sec = Secondary

\* Indicates a part manufactured by CDI Electronics | NOTE: Ignition Coils will read 0.2 to 1.0 ohms on the Primary and 200-400 ohms on the Secondary windings

Appendix

# Appendix

## Johnson/Evinrude DVA (Peak Reading) Voltage and Resistance Chart

| HP                | Year      | Model            | Ignition Part Number  | Stator  |  |   |                            |        |        | Trigger  |                     |                          |     |
|-------------------|-----------|------------------|---|---|--|---|----------------------------|--------|--------|--|---------------------|--------------------------|-----|
|                   |           |                  |   | Charge Coil   |  | Power Coil                                  |                            | Read   | Ohms   | DVA  | Read                | Ohms                     | DVA |
|                   |           |                  |   | Read  | Ohms                                       | Read  | Ohms                       |        |        |  |                     |                          |     |
| 125 COMM Mn Start | 1996-1998 | CD4              | 584032<br>113-4032*   | Brown to Brown/<br>Yellow                                       | 450-550                                    | 150-400V                                    | N/A                        | N/A    | N/A    | White to Blue/Purple/<br>Green/Pink  | 11-45               | 100-400V                 |     |
| 150-235           | 1976-1978 | Power Pack 3/6   | 581726<br>113-1726*   | Brown to Brown/<br>Yellow                                       | 400-600                                    | 150-400V                                    | N/A                        | N/A    | N/A    | White to Blue/Purple/<br>Green   | 10-20<br>30-40*     | 0.6V+                    |     |
| 150-235           | 1979-1988 | CD3/6 Dual Packs | 582138<br>582651<br>582817<br>583112<br>583114<br>583401<br>583605<br>113-2138*<br>113-2651*<br>113-2817*<br>113-3112*<br>113-3114*<br>113-3401*<br>113-3605* | Brown to Brown/<br>Yellow<br><br>Brown to Brown/<br>Yellow      | 9 AMP<br>450-550<br><br>35 AMP<br>950-1100 | 9 AMP<br>150-400V<br><br>35 AMP<br>150-400V | N/A                        | N/A    | N/A    | White to Blue/Purple/<br>Green   | 15-50               | 0.6V+                    |     |
| 150               | 1989-1991 | CD6              | 583816<br>584044<br>R584044*  | Brown to Brown/<br>Yellow<br><br>Brown/White to Brown/<br>Black | 450-550                                    | 150-400V                                    | N/A                        | N/A    | N/A    | Black to Blue/Purple/<br>Green<br><br>Black to Blue/White,<br>Purple/White and Green/White | 15-50<br><br>15-50  | 100-400V<br><br>100-400V |     |
| 150-175           | 1989-1992 | CD6 Cross-Flow   | 583865<br>113-3865*   | Brown to Brown/<br>Yellow<br><br>Brown/White to Brown/<br>Black | 900-1100                                   | 150-400V                                    | Orange to Orange/<br>Black | 93-103 | 11-22V | White to Blue/Purple/<br>Green<br><br>White to Black/White                                 | Open<br><br>215-225 | 100-400V<br><br>6-12V    |     |
| 150-175           | 1991-2006 | CD6              | 584985<br>584986<br>113-4985*<br>113-4986*  | Brown to Brown/<br>Yellow<br><br>Brown/White to Brown/<br>Black | 450-600                                    | 150-400V                                    | Orange to Orange/<br>Black | 50-60  | 11-22V | Orange/Red to Eng Gnd<br><br>Black/Orange to Eng Gnd                                       | N/A                 | 10.5-12 VDC<br>8-10 VDC  |     |
| 185-250           | 1988-2000 | CD6              | 584037<br>586212<br>113-4037*<br>113-6212*  | Brown to Brown/<br>Yellow                                       | 900-1100                                   | 150-400V                                    | Orange to Orange/<br>Black | 93-103 | 11-22V | White to Blue/Purple/<br>Green<br><br>White to Black/White                                 | Open<br><br>215-225 | 100-400V<br><br>6-12V    |     |
| 250-300           | 1988-1998 | CD8              | 584035<br>584642<br>113-4035*<br>113-4642*  | Brown to Brown/<br>Yellow                                       | 900-1100                                   | 150-400V                                    | Orange to Orange/<br>Black | 93-103 | 11-22V | White to Blue/Purple/<br>Green/Pink<br><br>White to Black/White                            | Open<br><br>215-225 | 100-400V<br><br>6-12V    |     |
| 275-300           | 1985-1987 | CD8 Quad Packs   | 568076<br>113-8076*   | Brown to Brown/<br>Yellow                                       | 950-1100                                   | 150-400V                                    | N/A                        | N/A    | N/A    | White to Blue and Green  | 35-55               | 0.6V+                    |     |
| 275-300           | 1985-1987 | CD4/8 Dual Packs | 583072<br>583101<br>113-3072*<br>113-3101*  | Brown to Brown/<br>Yellow                                       | 950-1100                                   | 150-400V                                    | N/A                        | N/A    | N/A    | White to Blue/Purple/<br>Green/Pink  | 35-55               | 0.6V+                    |     |

Blk = Black    Grn = Green    Pur = Purple    Yel = Yellow    Eng Gnd = Engine Ground    N/A = Not Applicable    Pri = Primary  
 Brn = Brown    Org = Orange    Wht = White    Eng Gnd = Engine Ground    COMM = Commercial    Sec = Secondary

\* Indicates a part manufactured by CDI Electronics

NOTE: Ignition Coils will read 0.2 to 1.0 ohms on the Primary and 200-400 ohms on the Secondary windings

# Appendix

## OMC Sea Drive DVA (Peak Reading) Voltage and Resistance Chart

| Engine       | Year | Model           | Ignition Part Number | Stator                |          |          |                     |        |        | Trigger                         |       |       | Ignition Coil Ohms |         |
|--------------|------|-----------------|----------------------|-----------------------|----------|----------|---------------------|--------|--------|---------------------------------|-------|-------|--------------------|---------|
|              |      |                 |                      | Charge Coil           |          |          | Power Coil          |        |        | Read                            | Ohms  | DVA   | Pri                | Sec     |
|              |      |                 |                      | Read                  | Ohms     | DVA      | Read                | Ohms   | DVA    |                                 |       |       |                    |         |
| 2.5/2.6L     | 1982 | "S"             | 582138<br>113-2138*  | Brown to Brown/Yellow | 450-600  | 150-400V | N/A                 | N/A    | N/A    | White to Blue/Purple/Green      | 35-45 | 0.6V+ | 0.2-1.0            | 200-400 |
| 1.6L         | 1983 | "S"             | 582125<br>113-2125*  | Brown to Brown/Yellow | 450-600  | 150-400V | N/A                 | N/A    | N/A    | White to Blue & Green           | 35-45 | 0.6V+ | 0.2-1.0            | 200-400 |
| 2.6L 10 AMP  | 1983 | 1AA/<br>2BA/2BB | 582556<br>113-2556*  | Brown to Brown/Yellow | 450-600  | 150-400V | N/A                 | N/A    | N/A    | White to Blue/Purple/Green      | 35-45 | 0.6V+ | 0.2-1.0            | 200-400 |
| 2.5L 35 AMP  | 1983 | 1AA/<br>2BA/2BB | 582138<br>113-2138*  | Brown to Brown/Yellow | 950-1100 | 150-400V | N/A                 | N/A    | N/A    | White to Blue/Purple/Green      | 35-45 | 0.6V+ | 0.2-1.0            | 200-400 |
| 1.6L V4      | 1984 | "S"             | 582125<br>113-2125*  | Brown to Brown/Yellow | 450-600  | 150-400V | N/A                 | N/A    | N/A    | White to Blue & Green           | 35-45 | 0.6V+ | 0.2-1.0            | 200-400 |
| 2.5L/2.6L V6 | 1984 |                 | 582556<br>113-2556*  | Brown to Brown/Yellow | 950-1100 | 150-400V | N/A                 | N/A    | N/A    | White to Blue/Purple/Green      | 35-45 | 0.6V+ | 0.2-1.0            | 200-400 |
| 1.6L V4      | 1985 | "S"             | 582811<br>113-2811*  | Brown to Brown/Yellow | 450-600  | 150-400V | N/A                 | N/A    | N/A    | White to Blue & Green           | 35-45 | 0.6V+ | 0.2-1.0            | 200-400 |
| 2.5L/2.6L V6 | 1985 |                 | 582651<br>113-2651*  | Brown to Brown/Yellow | 950-1100 | 150-400V | N/A                 | N/A    | N/A    | White to Blue/Purple/Green      | 35-45 | 0.6V+ | 0.2-1.0            | 200-400 |
| 1.6L V4      | 1986 | "S"             | 583110<br>113-3110*  | Brown to Brown/Yellow | 450-600  | 150-400V | N/A                 | N/A    | N/A    | White to Blue & Green           | 35-45 | 0.6V+ | 0.2-1.0            | 200-400 |
| 2.6L V6      | 1986 |                 | 583114<br>113-3114*  | Brown to Brown/Yellow | 950-1100 | 150-400V | N/A                 | N/A    | N/A    | White to Blue/Purple/Green      | 35-45 | 0.6V+ | 0.2-1.0            | 200-400 |
| 1.6L V4      | 1987 | "S"             | 583110<br>113-3110*  | Brown to Brown/Yellow | 450-600  | 150-400V | N/A                 | N/A    | N/A    | White to Blue & Green           | 35-45 | 0.6V+ | 0.2-1.0            | 200-400 |
| 1.8L V4      | 1987 | "S"             | 583101<br>113-3101*  | Brown to Brown/Yellow | 950-1100 | 150-400V | N/A                 | N/A    | N/A    | White to Blue/Purple/Green/Pink | 35-45 | 0.6V+ | 0.2-1.0            | 200-400 |
| 2.7L V6      | 1987 |                 | 583605<br>113-3605*  | Brown to Brown/Yellow | 950-1100 | 150-400V | N/A                 | N/A    | N/A    | White to Blue/Purple/Green      | 35-45 | 0.6V+ | 0.2-1.0            | 200-400 |
| 3.6L V8      | 1987 |                 | 583101<br>113-3101*  | Brown to Brown/Yellow | 950-1100 | 150-400V | N/A                 | N/A    | N/A    | White to Blue/Purple/Green/Pink | 35-45 | 0.6V+ | 0.2-1.0            | 200-400 |
| 1.6L V4      | 1988 | "S"             | 583110<br>113-3110*  | Brown to Brown/Yellow | 450-600  | 150-400V | N/A                 | N/A    | N/A    | White to Blue/Purple/Green/Pink | 35-45 | 0.6V+ | 0.2-1.0            | 200-400 |
| 2.0L V4      | 1988 | "S"             | 584041<br>113-4041*  | Brown to Brown/Yellow | 950-1100 | 150-400V | Orange to Org/Black | 93-103 | 11-22V | White to Blue/Purple/Green/Pink | 35-45 | 0.6V+ | 0.2-1.0            | 200-400 |
| 3.0L V6      | 1988 | "S"             | 584037<br>113-4037*  | Brown to Brown/Yellow | 950-1100 | 150-400V | Orange to Org/Black | 93-103 | 11-22V | White to Blue/Purple/Green      | Open  | 0.6V+ | 0.2-1.0            | 200-400 |
| 1.6L V4      | 1989 | "S"             | 583030<br>113-3030*  | Brown to Brown/Yellow | 450-600  | 150-400V | N/A                 | N/A    | N/A    | White to Blue/Purple/Green/Pink | 35-45 | 0.6V+ | 0.2-1.0            | 200-400 |
| 2.0L V4      | 1989 | "S"             | 584041<br>113-4041*  | Brown to Brown/Yellow | 950-1100 | 150-400V | Orange to Org/Black | 93-103 | 11-22V | White to Blue/Purple/Green/Pink | 35-45 | 0.6V+ | 0.2-1.0            | 200-400 |
| 3.0L V6      | 1989 | "S"             | 584037<br>113-4037*  | Brown to Brown/Yellow | 950-1100 | 150-400V | Orange to Org/Black | 93-103 | 11-22V | White to Blue/Purple/Green      | Open  | 0.6V+ | 0.2-1.0            | 200-400 |
| 4.0L V8      | 1989 | "S"             | 584035<br>113-4035*  | Brown to Brown/Yellow | 950-1100 | 150-400V | Orange to Org/Black | 93-103 | 11-22V | White to Blue/Purple/Green/Pink | Open  | 0.6V+ | 0.2-1.0            | 200-400 |
| 1.6L V4      | 1990 | "S"             | 583030<br>113-3030*  | Brown to Brown/Yellow | 450-600  | 150-400V | N/A                 | N/A    | N/A    | White to Blue/Purple/Green/Pink | 35-45 | 0.6V+ | 0.2-1.0            | 200-400 |
| 2.0L V4      | 1990 | "S"             | 584041<br>113-4041*  | Brown to Brown/Yellow | 950-1100 | 150-400V | Orange to Org/Black | 93-103 | 11-22V | White to Blue/Purple/Green/Pink | 35-45 | 0.6V+ | 0.2-1.0            | 200-400 |
| 3.0L V6      | 1990 | "S"             | 584037<br>113-4037*  | Brown to Brown/Yellow | 950-1100 | 150-400V | Orange to Org/Black | 93-103 | 11-22V | White to Blue/Purple/Green      | Open  | 0.6V+ | 0.2-1.0            | 200-400 |
| 4.0L V8      | 1990 | "S"             | 584035<br>113-4035*  | Brown to Brown/Yellow | 950-1100 | 150-400V | Orange to Org/Black | 93-103 | 11-22V | White to Blue/Purple/Green/Pink | Open  | 0.6V+ | 0.2-1.0            | 200-400 |

Blk = Black    Grn = Green    Pur = Purple    Yel = Yellow    Eng Gnd = Engine Ground    N/A = Not Applicable    Pri = Primary  
 Brn = Brown    Org = Orange    Wht = White    Gnd = Engine Ground    COMM = Commercial    Sec = Secondary

\* Indicates a part manufactured by CDI Electronics



# Appendix

## Yamaha DVA (Peak Reading) Voltage and Resistance Chart

| HP     | YEAR      | # Cyl | STK | Model            | Stator               |          |         |          |         |          | Trigger                           |                        |         | CDI Ohm Min | Ignition Coil |             | SPK CAP     |            |
|--------|-----------|-------|-----|------------------|----------------------|----------|---------|----------|---------|----------|-----------------------------------|------------------------|---------|-------------|---------------|-------------|-------------|------------|
|        |           |       |     |                  | Read                 |          | Ohms    |          | DVA Min |          | Read                              | Ohms                   | DVA Min |             | OHMS +/- 10%  |             |             |            |
|        |           |       |     |                  | Low Spd              | High Spd | Low Spd | High Spd | Low Spd | High Spd |                                   |                        |         |             | Primary       | Sec         |             |            |
| 2      | 1984-2002 | 1     | 2   |                  | Brown to Gnd         |          | 281-422 |          | 150     |          | N/A                               | N/A                    | N/A     | 130         | 0.21          | 2.56K-3.84K | N/A         |            |
| 2.5    | 2003-2005 | 1     | 4   | F                | TCI to Gnd           |          |         |          | 126     |          |                                   |                        |         | 126         | .56-.84       | 11.6K-17.4K | 4-6 K       |            |
| 3      | 1988-1999 | 1     | 2   |                  | Blk to Brown         |          | 250-300 |          | 150     |          | Blk to Wht/Red<br>Blk to Wht/Grn  | 30-36 LS<br>280-340 HS | 2       | 150         | 0.1           | 2.08K-3.12K | N/A         |            |
| 4      | 1984-1999 | 1     | 2   |                  | Blk to Brown         |          | 250-300 |          | 150     |          | Blk to Wht/Red<br>Blk to Wht/Grn  | 30-36 LS<br>280-340 HS | 2       | 150         | 0.1           | 2.48K-3.72K |             |            |
| 4      | 1999-2005 | 1     | 2   | F                | TCI to Gnd           |          |         |          | 126     |          |                                   |                        |         | 126         | .56-.84       | 11.6K-17.4K | 4.9-5.1K    |            |
| 5      | 1984-2002 | 1     | 2   |                  | Blk to Brown         |          | 250-300 |          | 150     |          | Blk to Wht/Red<br>Blk to Wht/Grn  | 30-36 LS<br>280-340 HS | 2       | 150         | 0.3           | 2.48K-3.72K | None        |            |
| 6      | 1986-2009 | 2     | 2   |                  | Blk to Brown         |          | 81-99   |          | 110     |          | Blk to Wht/Red                    |                        | 82-122  | 2.5         | 110           | 0.3         | 2.8K-4.2K   | None       |
| 6/8    | 2001-2004 | 2     | 4   | F                | Brown to Blue        |          | 232-348 |          | 154     |          | Blk to Wht/Red                    |                        | 240-360 | 3.5         | 140           | 0.3         | 7.8 K       | None       |
| 8      | 1986-2009 | 2     | 2   |                  | Blk to Brown         |          | 81-99   |          | 110     |          | Blk to Wht/Red                    |                        | 92-112  | 2           | 110           | 0.3         | 2.8K-4.2K   | None       |
| 9.9    | 1984-1992 | 2     | 2   |                  | Blk to Brown         |          | 81-99   |          | 110     |          | Blk to Wht/Red                    |                        | 92-112  | 2           | 110           | 0.3         | 2.8K-4.2K   | None       |
| 9.9    | 1993-1995 | 2     | 2   |                  | Blk to Brown         |          | 81-99   |          | 110     |          | Blk to Wht/Red                    |                        | 92-112  | 2           | 110           | 0.3         | 4.32K-6.48K | None       |
| 9.9/15 | 1996-2009 | 2     | 2   |                  | Blk to Brown         |          | 238-372 |          | 200     |          | Blk to Wht/Red                    |                        | 352-528 | 2.5         | 170           | 0.3         | 1.68K-2.42K | None       |
| 9.9    | 1984-1990 | 2     | 4   | F/FT/T (6G8/6G9) | Brown to Blue        |          | 569-695 |          | 100     |          | Blk to Wht/Red                    |                        | 172-212 | 2.5         | 85            | 0.16-0.24   | 2.72K-4.08K | None       |
| 9.9    | 1991-2004 | 2     | 4   | F/FT/T (6G8/6G9) | Brown to Blue        |          | 280-480 |          | 90      |          | Blk to Wht/Red                    |                        | 168-252 | 2.5         | 85            | 0.16-0.24   | 3.28K-4.92K | None       |
| 9.9    | 2005-2006 | 2     | 4   | F/T (66N/66R)    | Brown to Blue        |          | 272-408 |          | 135     |          | Blk to Wht/Grn                    |                        | 234-348 | 2.5         | 115           | 0.16-0.24   | 3.93K-5.89K | 4-6K       |
| 9.9    | 2007-2013 | 2     | 4   | F/T (68T)        | Brown to Blue        |          | 232-348 |          | 160     |          | Blk to White/<br>Red              |                        | 240-360 | 3.5         | 140           | 0.26-0.35   | 3.93K-5.89K | 4-6K       |
| 15     | 1984-1992 | 2     | 2   |                  | Blk to Brown         |          | 81-99   |          | 110     |          | Blk to Wht/Red                    |                        | 92-112  | 2           | 110           | 0.3         | 4.32K-6.48K | None       |
| 15     | 1996-2009 | 2     | 2   |                  | Blk to Brown         |          | 238-372 |          | 200     |          | Blk to Wht/Red                    |                        | 352-528 | 2.5         | 170           | 0.3         | 1.68K-2.42K | None       |
| 15     | 1998-2006 | 2     | 4   | F (66M)          | Brown to Black       |          | 272-408 |          | 135     |          | Blk to Wht/Red                    |                        | 234-348 | 3.5         | 115           | 0.3         | 3.93K-5.89K | 4-6K       |
| 15     | 2005-2013 | 2     | 4   | F15/20C (6AH)    | Blk/Red to Green/Red |          | 26-36   |          | 140     |          | Blk to Wht/Red                    |                        | 152-228 | 2.6         | 140           | 0.26-1.34   | 6.8K-10K    | 3.75-6.25K |
| 20     | 1996-1997 | 2     | 2   | 6L2-23           | Brown to Blue        |          | 304-456 |          | 125     |          | Blk to Wht/Red<br>Blk to Wht/Blk  | 277-415                | 5.5     | 105         | 0.18-0.24     | 2.56K-3.84K |             |            |
| 25     | 1984-1987 | 2     | 2   | 689              | Brown to Blk         |          | 120-160 |          | 190     |          | Blk to Wht/Red                    |                        | 12-16   | 5           | 210           | 0.18-0.24   | 2.8K-4.2K   | None       |
| 25     | 1988-1993 | 2     | 2   | 6L2-10           | Brown to Blue        |          | 160-240 |          | 100     |          | Blk to Wht/Red<br>Blk to Wht/Blk  | 260-390                | 5.5     | 100         | 0.18-0.24     | 2.02K-2.18K |             |            |
| 25     | 1994-2009 | 2     | 2   | 6L2-23           | Brown to Blue        |          | 304-456 |          | 125     |          | Blk to Wht/Red<br>Blk to Wht/Blk  | 277-415                | 5.5     | 105         | 0.18-0.24     | 2.56K-3.84K |             |            |
| 25     | 1996-2002 | 3     | 2   | 6J8              | Brown to Blue        |          | 164-246 |          | 175     |          | Blk to Wht/<br>Wht/Grn<br>Wht/Blk | 277-415                | 4       | 135         | 0.3           | 5.04K-7.56K | None        |            |
| 25     | 1990-1992 | 2     | 2   | C                | Blk to Brown         |          | 188-282 |          | 190     |          | Blk to Wht/Red                    |                        | 90-112  | 5           | 210           | 0.3         | 2.72K-3.68K | None       |
| 25     | 1993-1995 | 2     | 2   | C                | Blk to Brown         |          | 188-282 |          | 190     |          | Blk to Wht/Red                    |                        | 90-112  | 5           | 210           | 0.3         | 4.52K-6.28K | None       |
| 25     | 1996-1997 | 2     | 2   | C                | Blk to Brown         |          | 188-282 |          | 190     |          | Blk to Wht/Red                    |                        | 90-112  | 5           | 210           | 0.3         | 6.8K-10.2K  | None       |
| 25     | 1998-2006 | 2     | 4   | F/T (65W)        | Grn/Wht to Wht/Grn   |          | 660-710 |          | 190     |          | Red to White                      |                        | 260-390 | 6           | 190           | 0.08-0.11   | 3.28K-4.92K | None       |
| 25     | 1998-2006 | 2     | 4   | F/T (65W)        | Yel/Blk to Yel/Blk   |          | 6.5-7.3 |          | 7       |          | Power Coil                        |                        |         |             |               |             |             |            |
| 30     | 1984-1986 | 2     | 2   | 689              | Brown to Blk         |          | 120-160 |          | 190     |          | Blk to Wht/Red                    |                        | 12-16   | 5           | 210           | 0.18-0.24   | 2.8K-4.2K   | None       |
| 30     | 1987-2002 | 3     | 2   | 6J8              | Brown to Blue        |          | 164-246 |          | 175     |          | Blk to Wht/<br>Wht/Grn<br>Wht/Blk | 277-415                | 4       | 135         | 0.18-0.24     | 5.04K-7.56K | None        |            |
| 30     | 1989-1992 | 2     | 2   | C-689            | Blk to Brown         |          | 120-160 |          | 190     |          | Blk to Wht/Red                    |                        | 12-16   | 5           | 210           | 0.18-0.24   | 2.8K-4.2K   | None       |

Blk = Black    Grn = Green    Pur = Purple    Yel = Yellow    Eng Gnd = Engine Ground    N/A = Not Applicable    Pri = Primary  
 Brn = Brown    Org = Orange    Wht = White    Gnd = Engine Ground    COMM = Commercial    Sec = Secondary

**Appendix**

**Yamaha**  
**DVA (Peak Reading) Voltage and Resistance Chart**

| HP    | YEAR      | # Cyl | STK | Model     | Stator                  |          |            |          |         |          | Trigger                          |           |     | Ignition Coil |              |              |        | SPK PLG CAP |
|-------|-----------|-------|-----|-----------|-------------------------|----------|------------|----------|---------|----------|----------------------------------|-----------|-----|---------------|--------------|--------------|--------|-------------|
|       |           |       |     |           | Read                    |          | Ohms       |          | DVA     |          | Read                             | Ohms      | DVA | CDI Out       | OHMS +/- 10% |              |        |             |
|       |           |       |     |           | Low Spd                 | High Spd | Low Spd    | High Spd | Low Spd | High Spd |                                  |           |     |               | Primary      | Sec          |        |             |
| 30    | 1993-1996 | 2     | 2   | C         | Brown to Blue           |          | 356-580    |          | 125     |          | Blk to Wht/Red, Wht/Blk          | 304-430   | 4   | 100           | 0.18-0.24    | 2.56K-3.84K  | None   |             |
| 30    | 1997      | 2     | 2   | C         | Brown to Blue           |          | 304-475    |          | 125     |          | Blk to Wht/Red, Wht/Blk          | 304-430   | 4   | 100           | 0.18-0.24    | 2.56K-3.84K  | None   |             |
| 30    | 2001-2004 | 3     | 4   | F         | Grn/Wht to Wht/Grn      |          | 528-792    |          | 193     |          | Blk to Wht/Red                   | 300-350   | 6   | 151           | 0.3          | 3.28K-4.92   | None   |             |
| 40/50 | 1984-1988 | 3     | 2   |           | Brown to Blue           |          | 164-246    |          | 150     |          | Blk to Wht/Red, Wht/Grn, Wht/Blk | 277-415   | 3   | 135           | 0.3          | 5.04K-7.56K  | None   |             |
| 40/50 | 1989-1994 | 3     | 2   |           | Brown to Blue           |          | 238-356    |          | 200     |          | Blk to Wht/Red, Wht/Grn, Wht/Blk | 157-235   | 3   | 175           | 0.3          | 2.56K-3.84K  | None   |             |
| 40/50 | 1995-2009 | 3     | 2   |           | Brown to Blue           |          | 368-552    |          | 145     |          | Blk to Wht/Red, Wht/Grn, Wht/Blk | 168-252   | 3   | 125           | 0.3          | 2.56K-3.84K  | None   |             |
| 40    | 1989-1997 | 2     | 2   | C         | Brown to Black          |          | 120-148    |          | 190     |          | Blk to Wht/Red                   | 12.5-15.5 | 5   | 210           | 0.18-0.24    | 2.8K-4.2K    | None   |             |
| 40    | 1998-2003 | 3     | 2   | C, CV     | Brown to Blue           |          | 368-552    |          | 145     |          | Blk to Wht/Red, Wht/Grn, Wht/Blk | 168-252   | 4   | 125           | 0.3          | 2.8K-4.2K    | None   |             |
| 40    | 1999      | 4     | 4   | F         | Brown to Blue           |          | 272-408    |          | 140     |          | Red/Wht to White/Blk             | 340-510   | 7   | 150           | 0.3          | 3.28K-4.92K  | 4-6 K  |             |
| 40    | 2000-2004 | 3     | 4   | F         | Grn/Wht to Wht/Grn      |          | 528-792    |          | 193     |          | Blk to Wht/Red                   | 240-360   | 6   | 151           | 0.3          | 2.7K-3.7K    | 4-6 K  |             |
| 40    | 2000-2004 | 3     | 4   | F         | Yel/Blk to Yel/Blk      |          | 6.5-7.2    |          | 7       |          | Blk to Wht/Red                   | 240-360   | 6   | 151           | 0.3          | 2.7K-3.7K    | 4-6 K  |             |
| 40    | 2007-2008 | 3     | 4   | F40B      | Grn/Wht to Wht/Grn      |          | 660-710    |          | 190     |          | Blk to Red                       | 300-350   | 6.9 | 120           | 1.8-2.4      | 2.72-3.68K   | None   |             |
| 48    | 1995-2000 | 2     | 2   | E         | Blk to Brown            |          | 81-99      |          | 110     |          | Blk to Wht/Red                   | 82-122    | 4   | 170           | 0.3          | 4.62K-6.28K  | None   |             |
| 50    | 1998-2001 | 3     | 2   | C         | Brown to Blue           |          | 368-552    |          | 145     |          | Blk to Wht/Red, Wht/Grn, Wht/Blk | 168-252   | 3   | 125           | 0.3          | 2.8K-4.2K    | None   |             |
| 50    | 1995-2000 | 4     | 4   | F/T       | Brown to Blue           |          | 272-408    |          | 140     |          | Red/Wht to White/Blk             | 340-510   | 7   | 140           | 0.3          | 3.28K-4.92K  | 4-6 K  |             |
| 50    | 2001-2004 | 4     | 4   | F/T       | Brown to Blue           |          | 272-408    |          | 144     |          | Red/Wht to White/Blk             | 396-594   | 6.3 | 126           | 0.078-0.106  | 3.5K-4.7K    | 4-6 K  |             |
| 50    | 2005-2012 | 4     | 4   | F/T (EFI) | Blk/Red, Blk/Wht to Blk |          | CDI OUTPUT |          | 240     |          | Wht/Red to Wht/Blk               | 396-594   | 7.2 | 240           | 1.53-2.07    | 12.5K-16.91K | 1.9-5K |             |
| 55    | 1989-1994 | 2     | 2   | C         | Brown to Blue           |          | 188-282    |          | 135     |          | Blk to Wht/Red, Wht/Blk Blk      | 63-93     | 2   | 150           | 0.3          | 2.48K-3.72K  | None   |             |
| 55    | 1989-1994 | 2     | 2   | C         | Yellow to Black         |          | 22-30      |          | 10      |          | Blk to Wht/Red, Wht/Blk Blk      | 63-93     | 2   | 150           | 0.3          | 2.48K-3.72K  | None   |             |
| 55    | 1995      | 2     | 2   | C         | Brown to Blue           |          | 188-282    |          | 135     |          | Blk to Wht/Red, Blk to Wht/Blk   | 260-390   | 2   | 150           | 0.3          | 2.48K-3.72K  | None   |             |
| 60    | 1991      | 3     | 2   | P         | Brown to Blk            |          | 145-198    |          | 140     |          | Blk to Wht/Red, Wht/Grn, Wht/Blk | 104-156   | 2.5 | 100           | 0.3          | 3.84K-5.76K  | None   |             |
| 60    | 1995-2000 | 3     | 2   | E         | Brown to Black          |          | 145-198    |          | 140     |          | Blk to Wht/Red, Wht/Grn, Wht/Blk | 104-156   | 2.5 | 100           | 0.3          | 3.84K-5.76K  | None   |             |
| 60    | 1992-1999 | 3     | 2   | P         | Brown to Blue           |          | 136-204    |          | 150     |          | White/Red to White/Blk           | 260-360   | 2.5 | 105           | 0.3          | 3.28K-4.92K  | None   |             |
| 60    | 1992-1999 | 3     | 2   | P         | Crank Position Sensor   |          |            |          |         |          | Blue/Red to Blue/White           | 136-204   | 5   | @ CRANKING    |              |              |        |             |
| 60    | 1996-2001 | 3     | 2   | C         | Brown to Blue           |          | 136-204    |          | 150     |          | White/Red to White/Blk           | 260-360   | 2.5 | 105           | 0.3          | 3.28K-4.92K  | None   |             |
| 60    | 1996-2001 | 3     | 2   | C         | Crank Position Sensor   |          |            |          |         |          | Blue/Red to Blue/White           | 136-204   | 5   | @ CRANKING    |              |              |        |             |
| 60    | 2001-2005 | 3     | 2   |           | Brown to Blue           |          | 136-204    |          | 150     |          | White/Red to White/Blk           | 260-360   | 2.5 | (a)           | 0.3          | 3.28K-4.92K  |        |             |
| 60    | 2001-2005 | 3     | 2   |           | Crank Position Sensor   |          |            |          |         |          | Blue/Red to Blue/White           | 136-204   | 5   | @ CRANKING    |              |              |        |             |
| 60    | 2002-2004 | 4     | 4   | F/T       | Brown to Blue           |          | 272-408    |          | 137     |          | Red/Wht to White/Blk             | 396-594   | 3.5 | 150           | 0.078-0.106  | 3.5K-4.7K    | 4-6 K  |             |
| 60    | 2005-2012 | 4     | 4   | F/T (EFI) | Blk/Red, Blk/Wht to Blk |          | CDI OUTPUT |          | 240     |          | Wht/Red to Wht/Blk               | 396-594   | 7.2 | 240           | 1.53-2.07    | 12.5K-16.91K | 1.9-5K |             |

Blk = Black    Grn = Green    Pur = Purple    Yel = Yellow    Eng Gnd = Engine Ground    N/A = Not Applicable    Pri = Primary  
 Brn = Brown    Org = Orange    Wht = White    Gnd = Engine Ground    COMM = Commercial    Sec = Secondary

(a) 105 V on #1/3 idling (0 on #2), 145 V on all at 1500 RPM

Appendix

# Appendix

## Yamaha DVA (Peak Reading) Voltage and Resistance Chart

| HP     | YEAR      | # Cyl | STK | Model | Stator                         |                 |                      |                   |         |        | Trigger                                    |         |         | CDI Out | Ignition Coil |             | SPK PLG CAP |     |
|--------|-----------|-------|-----|-------|--------------------------------|-----------------|----------------------|-------------------|---------|--------|--|---------|---------|---------|---------------|-------------|-------------|-----|
|        |           |       |     |       | Read                           |                 | Ohms                 |                   | DVA     |        | Read                                       | Ohms    | DVA     |         | OHMS +/- 10%  |             |             |     |
|        |           |       |     |       | Low Spd                        | High Spd        | Low Spd              | High Spd          | Low Spd | Hi Spd |  |         |         |         | Primary       | Sec         |             |     |
| 70     | 1984-1991 | 3     | 2   |       | Brown to Blue                  |                 | 128-197              |                   | 140     |        | Blk to Wht/Red, Wht/Blk                    | 104-156 | 2.5     | 100     | 0.3           | 2.56K-3.84K |             |     |
| 70     | 1992-2009 | 3     | 2   |       | Brown to Blue                  |                 | 136-204              |                   | 150     |        | White/Red to White/Blk                     | 260-360 | 2.5     | (a)     | 0.3           | 3.28K-4.92K | None        |     |
| 70     | 1994-2001 | 3     | 2   | C     | Brown to Blk                   |                 | 145-198              |                   | 140     |        | Blk to Wht/Red, Wht/Blk                    | 104-156 | 2.5     | 105     | 0.3           | 3.28K-4.92K | 70          |     |
| 70     | 1994-2001 | 3     | 2   | C     | Crank Position Sensor          |                 |                      |                   |         |        | Blue/Red to Blue/White                     |         | 158-236 | 5       | @ CRANKING    |             |             |     |
| 75     | 1994-1996 | 3     | 2   | C     | Brn to Red                     | Blue to Red     | 840-1260<br>600-800  | 96-144<br>10-20   | 85      | 25     | Wht/Red to Wht/Yel<br>Wht/Grn to Wht/Blk   | 270-390 | 2.5     | 95      | 0.3           | 3.65K-4K    | None        |     |
| 75     | 1998-1999 | 3     | 2   | C     | Brn to Red                     | Red to Blue     | 191-288              | 64-96             | 60      | 100    | White/Red to White/Blk                     | 241-362 | 5       | (b)     | 0.3           | 3.28K-4.92K | None        |     |
| 75     | 1998-1999 | 3     | 2   | C     | Crank Position Sensor          |                 |                      |                   |         |        | Blue/Red to Blue/White                     |         | 158-236 | 5.5     | @ CRANKING    |             |             |     |
| 75     | 1995-1996 | 3     | 2   | E     | Brn to Blue                    | Red to Blue     | 840-1260<br>600-800  | 96-144<br>10-20   | 85      | 25     | Wht/Red to Wht/Yel<br>Wht/Grn to Wht/Blk   | 270-390 | 2.5     | 95      | 0.3           | 3.65K-4K    | None        |     |
| 75     | 1997-2000 | 3     | 2   | E     | Brn to Red                     | Red to Blue     | 428-642<br>600-800   | 48-72<br>10-20    | 105     | 45     | Wht/Red to White/Grn<br>Wht/Blk to Wht/Grn | 256-384 | 2.5     | 105     | 0.3           | 3.28K-4.92K |             |     |
| 75     | 1996-1999 | 3     | 2   | P     | Brn to Red                     | Red to Blue     | 191-288              | 64-96             | 60      | 100    | White/Red to White/Blk                     | 241-362 | 5       | (b)     | 0.3           | 3.28K-4.92K | None        |     |
| 75     | 1996-1999 | 3     | 2   | P     | Crank Position Sensor          |                 |                      |                   |         |        | Blue/Red to Blue/White                     |         | 158-236 | 5.5     | @ CRANKING    |             |             |     |
| 75/90  | 2003-2004 | 4     | 4   | F     | Blk/Wht to Blk, Blk/Org to Blk |                 | CDI OUTPUT           |                   |         | 107    | Blk to Wht/Red, Wht/Blk                    |         | 396-594 | 2.7     | 107           | 0.3         | 3.28K-4.92K | (c) |
| 80     | 1997      | 3     | 2   | P     | Brn to Red                     | Red to Blue     | 191-288              | 64-96             | 60      | 100    | White/Red to White/Blk                     | 241-362 | 5       | (b)     | 0.3           | 3.28K-4.92K | None        |     |
| 80     | 1997      | 3     | 2   | P     | Crank Position Sensor          |                 |                      |                   |         |        | Blue/Red to Blue/White                     |         | 158-236 | 5.5     | @ CRANKING    |             |             |     |
| 80/100 | 1999-2002 | 4     | 4   | F     | Blk/Wht to Blk, Blk/Org to Blk |                 | CDI OUTPUT           |                   |         | 107    | Blk to Wht/Red, Wht/Blk                    |         | 396-594 | 2.7     | 107           | 0.3         | 3.28K-4.92K | (c) |
| 85     | 1984-1989 | 3     | 2   | C     | Brn to Red                     | Red to Blue     | 765-935              | 105-135           | 85      | 45     | Wht/Red to White/Yel<br>Wht/Grn to Wht/Blk | 290-370 | 2.5     | 95      | 0.3           | 3.84K-5.76K | None        |     |
| 85     | 1990-1996 | 3     | 2   | C     | Brn to Red                     | Red to Blue     | 840-1260             | 105-140           | 85      | 45     | Wht/Red to White/Yel<br>Wht/Grn to Wht/Blk | 290-370 | 2.5     | 95      | 0.3           | 3.84K-5.76K | None        |     |
| 85     | 1989-1996 | 3     | 2   | CV    | Brn to Red                     | Red to Blue     | 840-1260<br>600-800  | 96-144<br>10-20   | 85      | 25     | Wht/Red to Wht/Yel<br>Wht/Grn to Wht/Blk   | 270-390 | 2.5     | 95      | 0.3           | 3.65K-4K    | None        |     |
| 90     | 1984-1989 | 4     | 2   |       | Brn to Red                     | Red to Blue     | 765-935              | 105-135           | 85      | 45     | Wht/Red to White/Yel<br>Wht/Grn to Wht/Blk | 290-370 | 2.5     | 95      | 0.3           | 2K-3K       | None        |     |
| 90     | 1990-1991 | 4     | 2   |       | Brn to Blue                    | Red to Blue     | 840-1260             | 105-140           | 85      | 45     | Wht/Red to White/Yel<br>Wht/Grn to Wht/Blk | 290-370 | 2.5     | 95      | 0.3           | 3.84K-5.76K | None        |     |
| 90     | 1992-2009 | 3     | 2   |       | Brn to Red                     | Red to Blue     | 191-288              | 64-96             | 60      | 100    | White/Red to White/Blk                     | 241-362 | 5       | (b)     | 0.3           | 3.28K-4.92K | None        |     |
| 90     | 1992-2009 | 3     | 2   |       | Crank Position Sensor          |                 |                      |                   |         |        | Blue/Red to Blue/White                     |         | 158-236 | 5.5     | @ CRANKING    |             |             |     |
| 90     | 1997-2001 | 3     | 2   | C     | Brn to Red                     | Red to Blue     | 191-288              | 64-96             | 60      | 100    | White/Red to White/Blk                     | 241-362 | 5       | (b)     | 0.3           | 3.28K-4.92K | None        |     |
| 90     | 1997-2001 | 3     | 2   | C     | Crank Position Sensor          |                 |                      |                   |         |        | Blue/Red to Blue/White                     |         | 158-236 | 5.5     | @ CRANKING    |             |             |     |
| 115    | 1984-1989 | 4     | 2   | B/P/S | Brn to Red                     | Blue to Blk/Red | 840-1260<br>600-800* | 102-152<br>10-20* | 150     | 45     | Wht/Red to White/Yel<br>Wht/Grn to Wht/Blk | 288-432 | 2.5     | 125     | 0.3           | 2K-3K       | None        |     |

Blk = Black    Grn = Green    Pur = Purple    Yel = Yellow    Eng Gnd = Engine Ground    N/A = Not Applicable    Pri = Primary  
 Brn = Brown    Org = Orange    Wht = White    Gnd = Engine Ground    COMM = Commercial    Sec = Secondary

\* Indicates a part manufactured by CDI Electronics  
 (a) 105 V on #1/3 idling (0 on #2), 145 V on all at 1500 RPM  
 (b) 130 V on #1/3 idling (0 on #2), 155 V on all at 1500 RPM  
 (c) #1 - 7.6K    #2 - 5.6 K    #3 - 6.3 K    #4 - 7.2 K

**Appendix**

**Yamaha  
DVA (Peak Reading) Voltage and Resistance Chart**

| HP      | YEAR      | # Cyl | STK | Mdl          | Stator                        |                 |                      |                   |        |  | Trigger  |         |            | CDI Out | Ignition Coil |             | SPK PLG CAP |
|---------|-----------|-------|-----|--------------|-------------------------------|-----------------|----------------------|-------------------|--------|--|--|---------|------------|---------|---------------|-------------|-------------|
|         |           |       |     |              | Read                          |                 | Ohms                 |                   | DVA    |  | Read   | Ohm     | DVA        |         | Primary       | Sec         |             |
|         |           |       |     |              | Low Spd                       | High Spd        | Low Spd              | High Spd          | Lo Spd | Hi Spd   |  |         |            |         |               |             |             |
| 115     | 1990-2010 | 4     | 2   | B/P/S        | Brn to Red                    | Blue to Blk/Red | 592-888<br>625-820*  | 55-83<br>10-20*   | 160    | 45   | Wht/Red to White/Yel<br>Wht/Grn to Wht/Blk                     | 256-384 | 2.5        | 125     | 0.25          | 3.04K-4.56K | 4-6K        |
| 115     | 1990-2000 | 4     | 2   | C            | Brn to Red                    | Blue to Blk/Red | 840-1260<br>625-820* | 55-83<br>10-20*   | 160    | 45   | Wht/Red to White/Yel<br>Wht/Grn to Wht/Blk                     | 288-432 | 2.5        | 125     | 0.25          | 2K-3K       | None        |
| 115     | 1997-1999 | 4     | 2   | C            | Brn to Red                    | Blue to Blk/Red | 840-1260<br>600-800* | 102-152<br>10-20* | 150    | 45   | Wht/Red to White/Yel<br>Wht/Grn to Wht/Blk                     | 288-432 | 2.5        | 125     | 0.25          | 2K-3K       | None        |
| 115     | 2000-2013 | 4     | 4   | F            | White to White to White       |                 | 0.24-0.36            |                   | 7.4    |  | Wht/Red, Wht/Blk to Black                                      | 459-561 | 3          | 122     | 1.87-2.53     | (d) (e)     |             |
| 130     | 1988-1989 | 4     | 2   |              | Brn to Red                    | Blue to Blk/Red | 840-1260<br>600-800* | 102-152<br>10-20* | 150    | 45   | Wht/Red to White/Yel<br>Wht/Grn to Wht/Blk                     | 288-432 | 2.5        | 125     | 0.25          | 2K-3K       | None        |
| 130     | 1990-2004 | 4     | 2   |              | Brn to Red                    | Blue to Blk/Red | 592-888              | 55-83             | 160    | 45   | Wht/Red to White/Yel<br>Wht/Grn to Wht/Blk                     | 256-384 | 2.5        | 125     | 0.25          | 3.04K-4.56K | 4-6K        |
| 130     | 1994-2002 | 4     | 2   | C/S          | Brn to Red                    | Blue to Blk/Red | 592-888              | 55-83             | 160    | 45   | Wht/Red to White/Yel<br>Wht/Grn to Wht/Blk                     | 288-432 | 2.5        | 125     | 0.25          | 3.04K-4.56K | 4-6K        |
| 150/175 | 1984-1989 | 6     | 2   |              | Brn to Red                    | Blue to Blk/Red | 840-1260<br>625-820* | 19-28<br>10-20*   | 75     | 14   | Wht/Red to Wht/Grn<br>Wht/Blk to Wht/Blk<br>Wht/Yel to Wht/Yel | 288-432 | 1.6        | 105     | 0.25          | 2K-3K       | None        |
| 150     | 1990-1995 | 6     | 2   |              | Brn to Red                    | Blue to Blk/Red | 592-888              | 55-83             | 145    | 40   | Wht/Red to Wht/Grn<br>Wht/Blk to Wht/Blk<br>Wht/Yel to Wht/Yel | 256-384 | 3          | 130     | 0.15-0.21     | 3.04K-4.56K | None        |
| 150     | 1996-2009 | 6     | 2   | D/L/P/S      | Brn to Red                    | Blue to Blk/Red | 592-888              | 55-88             | 145    | 40   | Wht/Red to Wht/Grn<br>Wht/Yel to Wht/Yel                       | 256-384 | 2          | 130     | 0.25          | 3.28K-4.92K | 4-6K        |
| 150     | 1996-2004 | 6     | 2   | D/L/P/S      | Crank Position Sensor         |                 |                      |                   |        | Green/White to Green/Blue  | 158-255  | 2       | @ CRANKING |         |               |             |             |
| 150     | 1996-1999 | 6     | 2   | C            | Brn to Red                    | Blue to Blk/Red | 428-642              | 64-96             | 90     | 30   | Wht/Red to Wht/Grn<br>Wht/Blk to Wht/Blk<br>Wht/Yel to Wht/Yel | 256-384 | 2          | 65      | 0.25          | 3.28K-4.92K | 4-6K        |
| 150     | 1999-2004 | 6     | 2   | DX SX VX EFI | Brn to Red<br>Blue to Blk/Red | 224-336         |                      | 115               |        | Blk to Wht/<br>Red, Wht/<br>Grn<br>Wht/Blk,<br>Wht/Blue,<br>Wht/Yel, Wht/<br>Brn | 294-398  | 3       | 100        | 0.25    | 2.72K- 3.68K  | 4-6K        |             |
| 150     | 1999-2004 | 6     | 2   | DX SX VX EFI | Crank Position Sensor         |                 |                      |                   |        | Green/Wht to Green/Blue  | 158-255  | 0.5     | @ CRANKING |         |               |             |             |
| 150     | 1999-2002 | 6     | 2   | LX/PX        | Brn to Red<br>Blue to Blk/Red | 224-336         |                      | 115               |        | Blk to Wht/<br>Red, Wht/<br>Grn<br>Wht/Blk,<br>Wht/Blue,<br>Wht/Yel, Wht/<br>Brn | 294-398  | 3       | 100        | 0.25    | 2.72K- 3.68K  | 4-6K        |             |
| 150     | 1999-2002 | 6     | 2   | LX/PX        | Crank Position Sensor         |                 |                      |                   |        | Green/Wht to Green/Blue  | 158-255  | 0.5     | @ CRANKING |         |               |             |             |
| 150     | 1994-1995 | 6     | 2   | P            | Brn to Red                    | Blue to Blk/Red | 55-83<br>10-20       | 145               | 40     | Wht/Red to Wht/Grn<br>Wht/Blk to Wht/Blue<br>Wht/Yel to Wht/Brn                  | 256-384  | 2       | 105        | 0.25    | 3.04K-4.56K   |             |             |

Blk = Black    Grn = Green    Pur = Purple    Yel = Yellow    Eng Gnd = Engine Ground    N/A = Not Applicable    Pri = Primary  
 Brn = Brown    Org = Orange    Wht = White    Gnd = Engine Ground    COMM = Commercial    Sec = Secondary

\* Indicates a part manufactured by CDI Electronics  
 (d) Check from spark plug lead #1 to #4. You should read from 18.97-35.23 K ohms.  
 (e) Check from spark plug lead #2 to #3. You should read from 18.55-34.45 K ohms.

Appendix

# Appendix

## Yamaha DVA (Peak Reading) Voltage and Resistance Chart

| HP  | YEAR      | # Cyl | STK | Model      | Stator  |                     |                      |                 |         | Trigger   |   |         | CDI Out    | Ignition Coil |              | SPK PLG CAP  |       |
|-----|-----------|-------|-----|------------|---|---------------------|----------------------|-----------------|---------|---|---|---------|------------|---------------|--------------|--------------|-------|
|     |           |       |     |            | Read  |                     | Ohms                 |                 | DVA     |   | Read  | Ohms    |            | DVA           | OHMS +/- 10% |              |       |
|     |           |       |     |            | Low Spd   | High Spd            | Low Spd              | High Spd        | Low Spd | High Spd  |   |         |            |               | Primary      |              | Sec   |
| 150 | 2000-2004 | 6     | 2   | Z/LZ VZ    | Red/Yellow to Black/Orange, Black/Yellow, Black/Blue, Black/Green and Black/White<br>CDI OUTPUT                               |                     |                      |                 |         | 140   | Whl/Red to Whl/Grn<br>Whl/Blk to Whl/Blue<br>Whl/Yel to Whl/Brn                   | ?       | 5          | 140           |              | 4-6 k        |       |
| 150 | 2004      | 6     | 4   | F/LF       | Blk to Blk/<br>Org<br>Blk to Blk/<br>Whl  |                     | ECM OUTPUT           |                 | 260     | Blk to Whl/<br>Red<br>Blk to Whl/Blk  |   | 459-561 | 3.5        | 260           | 1.53-2.07    | 12.5K-16.91K | None  |
| 175 | 1990-1995 | 6     | 2   |            | Brn to Red  | Blue to Blk/<br>Red | 592-888              | 55-83           | 145     | 40  | Whl/Red to Whl/Grn<br>Whl/Blk to Whl/Blue<br>Whl/Yel to Whl/Brn                   | 256-384 | 3          | 130           | 0.15-0.21    | 3.04K-4.56K  | None  |
| 175 | 1996-2000 | 6     | 2   | P/S        | Brn to Red  | Blue to Blk/<br>Red | 592-888              | 55-88           | 145     | 40  | Whl/Red to Whl/Grn<br>Whl/Yel to Whl/Brn  | 256-384 | 2          | 130           | 0.5          | 3.28K-4.92K  | 4-6K  |
| 175 | 1996-2000 | 6     | 2   | P/S        | Crank Position Sensor   |                     |                      |                 |         | Green/Whl to Green/Blue   | 158-236   | 2       | @ Cranking |               |              |              |       |
| 175 | 2001-2004 | 6     | 2   | Z/VZ       | Blk/Org to Red/Yel<br>Blk/Yel to Red/Yel<br>Blk/Blue to Red/Yel<br>Blk/Grn to Red/Whl<br>Yel Blk/Whl to Red/Yel<br>CDI OUTPUT |                     |                      |                 |         | 140   | Blk to Whl/<br>Red, Whl/<br>Grn,<br>Whl/Blk,<br>Whl/Blue,<br>Whl/Yel, Whl/<br>Brn | ?       | 5          | 140           | 1.97-2.53    | 8.93K-12.08K | 4-6K  |
| 175 | 2001-2004 | 6     | 2   | Z/VZ       | Crank Position Sensor   |                     |                      |                 |         | Green/Whl to Green/Blue   | 178.5-241.5   | 4       | @ CRANKING |               |              |              |       |
| 175 | 2001-2004 | 6     | 2   | Z/VZ       | Throttle Position Sensor  |                     |                      |                 |         | Org to Pink   |   |         | 0.58-0.62  | IDLING        |              |              |       |
| 175 | 2001-2004 | 6     | 2   | Z/VZ       | O2 Sensor   |                     |                      |                 |         | Red/Whl to Black  | 2-100   |         | STATIC     |               |              |              |       |
| 200 | 1984-1989 | 6     | 2   |            | Brn to Red  | Blue to Blk/<br>Red | 840-1260<br>625-820* | 19-28<br>10-20* | 75      | 14  | Whl/Red to Whl/Grn<br>Whl/Blk to Whl/Blue<br>Whl/Yel to Whl/Brn                   | 288-432 | 1.6        | 105           | 0.15-0.21    | 2K-3K        | None  |
| 200 | 1990-1995 | 6     | 2   |            | Brn to Red  | Blue to Blk/<br>Red | 592-888              | 55-83           | 145     | 40  | Whl/Red to Whl/Grn<br>Whl/Blk to Whl/Blue<br>Whl/Yel to Whl/Brn                   | 256-384 | 2          | 105           | 0.15-0.21    | 3.04K-4.56K  | None  |
| 200 | 1991-1995 | 6     | 2   | P          | Brn to Red  | Blue to Blk/<br>Red | 592-888              | 55-83           | 140     | 40  | Whl/Red to Whl/Grn<br>Whl/Yel to Whl/Brn  | 256-384 | 3          | 130           | 0.15-0.21    | 3.04K-4.56K  | 4-6K  |
| 200 | 1996-2009 | 6     | 2   | L/P/S      | Brn to Red  | Blue to Blk/<br>Red | 592-888              | 55-83           | 140     | 40  | Whl/Red to Whl/Grn<br>Whl/Yel to Whl/Brn  | 256-384 | 3          | 130           | 0.5          | 3.28K-4.92K  | 4-6K  |
| 200 | 1999-2002 | 6     | 2   | LX (EFI)   | Brn to Red<br>Blue to Blk/Red   |                     | 224-336              |                 | 115     |   | Blk to Whl/<br>Red, Whl/<br>Grn,<br>Whl/Blk,<br>Whl/Blue,<br>Whl/Yel, Whl/<br>Brn | 294-398 | 3          | 100           | 0.5          | 2.7K- 3.6K   | 4-6 K |
| 200 | 1999-2002 | 6     | 2   | LX (EFI)   | Crank Position Sensor   |                     |                      |                 |         | Green/White to Green/Blue   | 179-242   | 0.5     | @ CRANKING |               |              |              |       |
| 200 | 1998-2005 | 6     | 2   | V/VX (EFI) | Brn to Red<br>Blue to Blk/<br>Red   | 224-336             |                      | 115             |         | Blk to Whl/<br>Red, Whl/<br>Grn,<br>Whl/Blk,<br>Whl/Blue,<br>Whl/Yel, Whl/<br>Brn | 294-398   | 3       | 100        | 0.5           | 2.7K- 3.6K   | 4-6 K        |       |
| 200 | 1998-2005 | 6     | 2   | V/VX (EFI) | Crank Position Sensor   |                     |                      |                 |         | Green/White to Green/Blue   | 179-242   | 0.5     | @ CRANKING |               |              |              |       |
| 200 | 2001-2004 | 6     | 2   | VZ (EFI)   | B/O<br>B/Y<br>B/L<br>B/Br<br>B/G<br>B/W<br>to<br>Red/<br>Yel<br>CDI OUTPUT  |                     |                      |                 |         | 140   | Blk to Whl/<br>Red, Whl/<br>Grn,<br>Whl/Blk,<br>Whl/Blue,<br>Whl/Yel, Whl/<br>Brn | 294-398 | 4          | 140           |              | 4-6K         |       |

Blk = Black    Grn = Green    Pur = Purple    Yel = Yellow    Eng Gnd = Engine Ground    N/A = Not Applicable    Pri = Primary  
 Brn = Brown    Org = Orange    Whl = White

\* Indicates a part manufactured by CDI Electronics



**Appendix**

**Yamaha**  
**DVA (Peak Reading) Voltage and Resistance Chart**

| HP  | YEAR      | # Cyl | STK | Model     | Stator  |                 |                             |                        |         |          | Trigger  |  |           | Ignition Coil |              | SPK PLG CAP  |                  |      |
|-----|-----------|-------|-----|-----------|---|-----------------|-----------------------------|------------------------|---------|----------|--|--|-----------|---------------|--------------|--------------|------------------|------|
|     |           |       |     |           | Read  |                 | Ohms                        |                        | DVA     |          | Read   | Ohms   | DVA       | CDI Out       | OHMS +/- 10% |              |                  |      |
|     |           |       |     |           | Low Spd   | High Spd        | Low Spd                     | High Spd               | Low Spd | High Spd |  |  |           |               | Primary      |              | Sec              |      |
| 200 | 2001-2004 | 6     | 2   | VZ (EFI)  | Crank Position Sensor   |                 |                             |                        |         |          | Green/White to Green/Blue                                    | 179-242  | 4         | @ CRANKING    |              |              |                  |      |
| 200 | 2001-2004 | 6     | 2   | VZ (EFI)  | O2 Position Sensor  |                 |                             |                        |         |          | Red/White to Black   | 2-100  |           |               |              |              |                  |      |
| 200 | 2005      | 6     | 2   | VZ (EFI)  | B/O, B/Y, B/L, B/Br, B/G, B/W to Red/Yel                        | CDI OUTPUT      |                             | 270                    |         |          | Blk to Wht/Red, Wht/Grn, Wht/Blk, Wht/Blue, Wht/Yel, Wht/Brn | 294-398  | 4         | 270           | 1.87-2.53    | 8.93K-12.08K |                  |      |
| 200 | 2005      | 6     | 2   | VZ        | Crank Position Sensor   |                 |                             |                        |         |          | Green/White to Green/Blue                                    | 179-242  | 0.5       | @ CRANKING    |              |              |                  |      |
| 200 | 2005      | 6     | 2   | VZ        | Throttle Position Sensor  |                 |                             |                        |         |          | Pink to Org  |  | 0.58-0.62 | IDLNG         |              |              |                  |      |
| 200 | 1999-2004 | 6     | 2   | SX        | Blk/Org, Blk/Yel, Blk/Blue, Blk/Brn, Blk/Gm, Blk/Wht to Red/Yel |                 | N/A                         |                        | 100     |          |  | Blk to Wht/Red, Wht/Grn, Wht/Blk, Wht/Blue, Wht/Yel, Wht/Brn | 3         | 100           |              |              | 4-6 K            |      |
| 200 | 1999-2004 | 6     | 2   | V/VX      | Brn to Red  | Blue to Blk/Red | 224-336                     |                        | 115     |          |  | Blk to Wht/Red, Wht/Grn, Wht/Blk, Wht/Blue, Wht/Yel, Wht/Brn | 294-398   | 3             | 100          | 0.5          | 2.7K-3.6K        | 5 K  |
| 200 | 2000-2004 | 6     | 2   | LZ/Z HPDI | Blk/Org, Blk/Yel, Blk/Blue, Blk/Brn, Blk/Gm, Blk/Wht to Red/Yel |                 | CDI OUTPUT                  |                        | 140     |          |  | Blk to Wht/Red, Wht/Grn, Wht/Blk, Wht/Blue, Wht/Yel, Wht/Brn | ?         | 5             | 140          | 0.5          | 4-6K             |      |
| 200 | 2000-2004 | 6     | 2   | LZ/Z HPDI | Crank Position Sensor   |                 |                             |                        |         |          | Green/White to Green/Blue                                    | 179-242  | 4         | @ CRANKING    |              |              |                  |      |
| 200 | 2002-2011 | 6     | 4   | F (EFI)   | Blk/Org, Blk/Yel, Blk/Blue, Blk/Wht to Black                    |                 | CDI OUTPUT                  |                        | 205     |          |  | Wht/Red, Wht/Blk, Wht/Grn to Blk                             | 459-561   | 5.3           | 252          | 1.5-1.9      | 19.6 - 35.4K (f) | None |
| 220 | 1984-1986 | 6     | 2   | Special   | Brn to Red  | Blue to Blk/Red | <u>840-1260</u><br>625-820* | <u>19-28</u><br>10-20* | 75      | 14       | Wht/Red to Wht/Grn Wht/Blk to Wht/Blue Wht/Yel to Wht/Brn    |  | 288-432   | 1.6           | 105          | 0.25         | 2K-3K            | 4-6K |
| 225 | 1987-1989 | 6     | 2   | Excel     | Brn to Red  | Blue to Blk/Red | <u>840-1260</u><br>625-820* | <u>19-28</u><br>10-20* | 75      | 14       | Wht/Red to Wht/Grn Wht/Blk to Wht/Blue Wht/Yel to Wht/Brn    |  | 288-432   | 1.6           | 105          | 0.25         | 2K-3K            | 4-6K |
| 225 | 1987-1989 | 6     | 2   | Excel     | Crank Position Sensor   |                 |                             |                        |         |          | Green/White to Green/Blue                                    | 568-852  | 2         | @ CRANKING    |              |              |                  |      |
| 225 | 1990-1995 | 6     | 2   | L/HP      | Brn to Red  | Blue to Blk/Red | 592-888                     | 55-83                  | 145     | 40       | Wht/Red to Wht/Grn Wht/Blk to Wht/Blue Wht/Yel to Wht/Brn    |  | 256-384   | 2             | 105          | 0.25         | 3.04K-4.56K      | 4-6K |
| 225 | 1994-1995 | 6     | 2   | U/X       | Brn to Red<br>Blue to Blk/Red                                   |                 | 224-336                     |                        | 100     |          |  | Blk to Wht/Red, Wht/Grn, Wht/Blk, Wht/Blue, Wht/Yel, Wht/Brn | 277-415   | 2             | 100          | 0.25         | 2.16k-3.24k      | 4-6k |
| 225 | 1994-1995 | 6     | 2   | U/X       | Crank Position Sensor   |                 |                             |                        |         |          | Brown to Red   | 179-242  | 0.5       | @ CRANKING    |              |              |                  |      |
| 225 | 1996      | 6     | 2   | S         | Brn to Red<br>Blue to Blk/Red                                   |                 | 224-336                     |                        | 100     |          |  | Blk to Wht/Red, Wht/Grn, Wht/Blk, Wht/Blue, Wht/Yel, Wht/Brn | 294-398   | 3             | 100          | 0.25         | 2.7K-3.6K        | 4-6K |
| 225 | 1996      | 6     | 2   | S         | Crank Position Sensor   |                 |                             |                        |         |          | Green/White to Green/Blue                                    | 179-242  | 0.5       | @ CRANKING    |              |              |                  |      |

Blk = Black    Grn = Green    Pur = Purple    Yel = Yellow    Eng Gnd = Engine Ground    N/A = Not Applicable    Pri = Primary  
 Brn = Brown    Org = Orange    Wht = White    Gnd = Engine Ground    COMM = Commercial    Sec = Secondary

Indicates a part manufactured by CDI Electronics (f) Read between the output leads of each coil.

**Appendix**

# Appendix

## Yamaha DVA (Peak Reading) Voltage and Resistance Chart

| HP  | YEAR      | # Cyl | STK | Model               | Stator                                |                 |            |          |         |          | Trigger  |         |     | CDI Out    | Ignition Coil |              | SPK PLG CAP |
|-----|-----------|-------|-----|---------------------|---------------------------------------|-----------------|------------|----------|---------|----------|--|---------|-----|------------|---------------|--------------|-------------|
|     |           |       |     |                     | Read                                  |                 | Ohms       |          | DVA     |          | Read   | Ohms    | DVA |            | OHMS +/- 10%  |              |             |
|     |           |       |     |                     | Low Spd                               | High Spd        | Low Spd    | High Spd | Low Spd | High Spd |  |         |     |            | Primary       | Sec          |             |
| 225 | 1996-1997 | 6     | 2   | L/HP                | Brn to Red                            | Blue to Blk/Red | 592-888    | 55-88    | 140     | 40       | Wht/Red to Wht/Grn<br>Wht/Blk to Wht/Blue<br>Wht/Yel to Wht/Brn          | 280-460 | 2   | 130        | 0.25          | 3.28K-4.92K  | 4-6K        |
| 225 | 1996-1997 | 6     | 2   | L/HP                | Crank Position Sensor                 |                 |            |          |         |          | Brown to Red   | 179-242 | 2   | @ CRANKING |               |              |             |
| 225 | 1998-2002 | 6     | 2   | S/X/U<br>L/LX<br>SX | Brn to Red<br>Blue to Blk/Red         |                 | 224-336    |          | 115     |          | Blk to Wht/Red,<br>Wht/Grn,<br>Wht/Blk,<br>Wht/Blue,<br>Wht/Yel, Wht/Brn | 294-398 | 3   | 100        | 0.25          | 2.16K-3.24K  | 5 K         |
| 225 | 1998-2002 | 6     | 2   | S/X/U<br>L/LX<br>SX | Crank Position Sensor                 |                 |            |          |         |          | Green/White to Green/Blue  | 179-242 | 0.5 | @ Cranking |               |              |             |
| 225 | 2002-2005 | 6     | 4   | F (EFI)             | Blk/Org, Blk/Yel,<br>Blk/Wht to Black |                 | CDI OUTPUT |          | 252     |          | Wht/Red, Wht/Grn,<br>Wht/Blk to Black                                    | 459-561 | 5.3 | 252        | 1.5-1.9       | 19.6K-35.4K  | None        |
| 225 | 2002-2005 | 6     | 4   | F (EFI)             | Crank Position Sensor                 |                 |            |          |         |          | Pink to Blk  | 179-242 | 0.5 | @ Cranking |               |              |             |
| 225 | 1998-2004 | 6     | 2   | VX                  | Brn to Red                            | Blue to Blk/Red | 224-336    |          | 115     |          | Blk to Wht/Red,<br>Wht/Grn,<br>Wht/Blk,<br>Wht/Blue,<br>Wht/Yel, Wht/Brn | 294-398 | 3   | 100        | 0.25          | 2.16K-3.24K  | 4-6 K       |
| 225 | 1998-2004 | 6     | 2   | VX                  | Crank Position Sensor                 |                 |            |          |         |          | Pink to Blk  | 179-242 | 0.5 | @ Cranking |               |              |             |
| 225 | 2003-2009 | 6     | 2   | VZ<br>HPDI          | Red to Blk/Wht                        |                 | CDI OUTPUT |          | 160     |          | Blk to Wht/Red,<br>Wht/Grn,<br>Wht/Blk,<br>Wht/Blue,<br>Wht/Yel, Wht/Brn | 294-398 | 3.5 | 160        | 1.87-2.53     | 8.93-12.08 K | None        |
| 225 | 2005-2009 | 6     | 2   | VZ<br>HPDI          | Crank Position Sensor                 |                 |            |          |         |          | Grn/Wht to Grn/Blue  | 158-236 | 0.5 | @ Cranking |               |              |             |
| 250 | 1990-1999 | 6     | 2   | L/S                 | Brn to Red<br>Blue to Blk/Red         |                 | 224-336    |          | 115     |          | Blk to Wht/Red,<br>Wht/Grn,<br>Wht/Blk,<br>Wht/Blue,<br>Wht/Yel, Wht/Brn | 294-398 | 3   | 100        | 0.25          | 2.16K-3.24K  | 4-6K        |
| 250 | 1990-1999 | 6     | 2   | L/S                 | Crank Position Sensor                 |                 |            |          |         |          | Grn/Wht to Grn/Blue  | 158-236 | 0.5 | @ Cranking |               |              |             |
| 250 | 2000-2003 | 6     | 2   | L/S                 | Brn to Red<br>Blue to Blk/Red         |                 | 224-336    |          | 115     |          | Blk to Wht/Red,<br>Wht/Grn,<br>Wht/Blk,<br>Wht/Blue,<br>Wht/Yel, Wht/Brn | 294-398 | 3   | 100        | 0.3           | 2.16K-3.24K  | 4-6K        |
| 250 | 2000-2003 | 6     | 2   | L/S                 | Crank Position Sensor                 |                 |            |          |         |          | Grn/Wht to Grn/Blue  | 158-236 | 0.5 | @ Cranking |               |              |             |
| 250 | 2003-2009 | 6     | 2   | LZ/NZ<br>Z HPDI     | Red to Blk/Wht                        |                 | CDI OUTPUT |          | 160     |          | Blk to Wht/Red,<br>Wht/Grn,<br>Wht/Blk,<br>Wht/Blue,<br>Wht/Yel, Wht/Brn | 294-398 | 3.5 | 140        | 1.87-2.53     | 8.93-12.08 K | None        |
| 250 | 2003-2009 | 6     | 2   | LZ/NZ<br>Z HPDI     | Crank Position Sensor                 |                 |            |          |         |          | Grn/Wht to Grn/Blue  | 158-236 | 1.5 | @ Cranking |               |              |             |
| 300 | 2004-2009 | 6     | 2   | LZ/NZ<br>Z HPDI     | Red to Blk/Wht                        |                 | CDI OUTPUT |          | 265     |          | Blk to Wht/Red,<br>Wht/Grn,<br>Wht/Blk,<br>Wht/Blue,<br>Wht/Yel, Wht/Brn | 294-398 | 3.5 | 265        | 1.36-1.84     | 7.31 - 9.89K | None        |
| 300 | 2004-2009 | 6     | 2   | LZ/NZ<br>Z HPDI     | Crank Position Sensor                 |                 |            |          |         |          | Grn/Wht to Grn/Blue  | 158-236 | 1.5 | @ Cranking |               |              |             |

Blk = Black    Grn = Green    Pur = Purple    Yel = Yellow    Eng Gnd = Engine Ground    N/A = Not Applicable    Pri = Primary  
 Brn = Brown    Org = Orange    Wht = White    Gnd = Engine Ground    COMM = Commercial    Sec = Secondary

\* Indicates a part manufactured by CDI Electronics

**Appendix**

**Mercury**  
**DVA (Peak Reading) Voltage and Resistance Chart**

| HP                                     | Year          | Serial#               | Ignition Part Number                                    | Stator                            |                      |                                 |                     |              |                                     | Trigger  |              |       |
|--|---------------|-----------------------|---|-----------------------------------|----------------------|---------------------------------|---------------------|--------------|-------------------------------------|--|--------------|-------|
|  |               |                       |   | Read                              |                      | Ohms                            |                     | DVA          |                                     | Read   | Ohms         | DVA   |
|  |               |                       |   | Low Spd                           | High Spd             | Low Spd                         | High Spd            | Low Spd      | High Spd                            |  |              |       |
| 4<br>1 CYL                             | 1972-<br>1975 | 3296137-<br>A855096   | 336-4516  | Green to Engine Ground (DVA only) |                      | 2100-2300<br>(a)                | 170-190<br>(b)      | 180-<br>400V | Points<br>Brown & White             | N/A  | N/A          |       |
| 4-20<br>2 CYL                          | 1972-<br>1989 | 3069294-<br>A855096   | 336-4516  | Green to Engine Ground (DVA only) |                      | 2100-2300<br>(a)                | 170-190<br>(b)      | 180-<br>400V | Points<br>Brown & White             | N/A  | N/A          |       |
| 4-20<br>2 CYL                          | 1974-<br>1986 | 3795659-<br>A197111   | 339-6222<br>114-6222*                                   | Orange to<br>Engine Ground        |                      | 1600-1800<br>(800-900 per coil) |                     | 180-<br>400V | Brown to Brown or<br>Brown to White | 800-<br>1400   | 0.5V+        |       |
| 6-35<br>2 CYL                          | 1979-<br>1997 | 5705532-<br>OG760299  | 339-7452<br>114-7452K1*                                 | Blk/Yel to<br>Eng Gnd             | Blk/Wh to<br>Eng Gnd | 3250-3650<br>2000-2400*         | 150-250<br>200-250* | 180-<br>400V | 25-<br>100V                         | Brown/Yellow to<br>Brown/White                           | 800-<br>1400 | 0.5V+ |
| 6-25<br>2 CYL                          | 1997-<br>2006 | OG760300-<br>1B999999 | 855721<br>114-5713*                                     | Green/White to<br>White/Green     |                      | 660-710<br>350-450*             |                     | 180-<br>400V |                                     | Brown/Yellow to<br>Brown/White                           | 850-<br>1100 | 4V+   |
| 15-25<br>2 CYL                         | 1994-<br>1998 | OG044027-<br>OG760299 | 18495A30<br>114-4952A30*                                | Blue to<br>Black                  | Red to<br>Black      | 2900-3500<br>2000-2600*         | 100-180<br>200-250* | 180-<br>400V | 25-<br>100V                         | Brown to White   | 800-<br>1400 | 4V+   |
| 18-40<br>2 CYL                         | 1979-<br>1989 | 5837437-<br>OB393190  | 339-7452A3<br>114-7452A3*                               | Blk/Yel to<br>Eng Gnd             | Blk/Wh to<br>Eng Gnd | 3250-3650<br>2000-2400*         | 150-250<br>200-250* | 180-<br>400V | 25-<br>100V                         | Brown/Yellow to<br>Brown/White                           | 800-<br>1400 | 0.5V+ |
| 20-40<br>2 CYL                         | 1972-<br>1981 | 3336258-<br>5823917   | 332-4733<br>332-4911<br>338-4733<br>114-4911*<br>822779 | Blue to<br>Eng Gnd                | Red to<br>Eng Gnd    | 5200-7400                       | 180-340             | 180-<br>400V | 25-<br>100V                         | Brown to White   | 140-160      | 0.5V+ |
| 30-40<br>CDM<br>2 CYL                  | 1994-<br>2005 | OG053314-<br>OT999999 | 827509<br>114-7509*<br>114-7509K1*                      | Green/White to<br>White/Green     |                      | 500-700<br>500-600*             |                     | 180-<br>400V |                                     | Engine Gnd to<br>White<br>and Purple                     | Open         | 1V+   |
| 40<br>2 CYL                            | 1970-<br>1971 | 2874704-<br>3336237   | 332-4172  | Blue to<br>Eng Gnd                | White to<br>Eng Gnd  | 3200-3800<br>2000-2600*         | 45-55<br>45-55*     | 180-<br>400V | 25-<br>100V                         | Brown to<br>Engine Ground                                | N/A          | 1V+   |
| 30-90<br>CDM<br>3 CYL                  | 1996-<br>2007 | OG438000-<br>1B999999 | 827509<br>114-7509*                                     | Green/White to<br>White/Green     |                      | 500-700<br>500-600*             |                     | 180-<br>400V |                                     | Engine Gnd to<br>Brown, White<br>and Purple              | Open         | 1V+   |
| 45-60<br>3 CYL                         | 1991-<br>1997 | OD000750-<br>OG589999 | 19052<br>114-9052*                                      | Blue to<br>Eng Gnd                | Red to<br>Eng Gnd    | 3250-3650<br>500-600*           | 75-90<br>28-32*     | 180-<br>400V | 25-<br>100V                         | White/Black to<br>Brown, White<br>and Purple             | 800-<br>1400 | 4V+   |
| 45-60<br>Red<br>Stator Kit<br>3 CYL    | 1991-<br>1997 | OD000750-<br>OG589999 | 19052<br>114-9052*                                      | Green/White to<br>White/Green     |                      | 500-700<br>500-600*             |                     | 180-<br>400V |                                     | White/Black to<br>Brown, White<br>and Purple             | 800-<br>1400 | 4V+   |
| 50-70<br>Bolted-in<br>Magnets<br>3 CYL | 1976-<br>1990 | 4382057-<br>OD000749  | 332-7778<br>114-7778*                                   | Blue to<br>Eng Gnd                | Red to<br>Eng Gnd    | 5800-7000<br>2000-2400*         | 135-165<br>45-55*   | 180-<br>400V | 25-<br>100V                         | White/Black to<br>Brown, White<br>and Purple             | 800-<br>1400 | 4V+   |
| 50-90<br>Red<br>Stator Kit<br>3 CYL    | 1976-<br>1994 | 4382057-<br>OE033710  | 332-7778<br>114-7778*                                   | Green/White to<br>White/Green     |                      | 500-700<br>500-600*             |                     | 180-<br>400V |                                     | White/Black to<br>Brown, White<br>and Purple             | 800-<br>1400 | 4V+   |
| 65-95<br>3 CYL                         | 1994-<br>1996 | OD283222-<br>OG760299 | 18495<br>114-4953*                                      | Blue to<br>Eng Gnd                | Red to<br>Eng Gnd    | 3250-3650<br>500-600*           | 75-90<br>28-32*     | 180-<br>400V | 25-<br>100V                         | White/Black to<br>Brown, White<br>and Purple             | 800-<br>1400 | 4V+   |
| 65-95<br>Red<br>Stator Kit<br>3 CYL    | 1994-<br>1996 | OD283222-<br>OG760299 | 18495<br>114-4953*                                      | Green/White to<br>White/Green     |                      | 500-700<br>500-600*             |                     | 180-<br>400V |                                     | White/Black to<br>Brown, White<br>and Purple             | 800-<br>1400 | 4V+   |
| 70-90<br>Glued-in<br>Magnets<br>3 CYL  | 1977-<br>1994 | 4571652-<br>OE033710  | 332-7778<br>114-7778*                                   | Blue to<br>Eng Gnd                | Red to<br>Eng Gnd    | 3250-3650<br>500-600*           | 135-165<br>30-90*   | 180-<br>400V | 25-<br>100V                         | White/Black to<br>Brown, White<br>and Purple             | 800-<br>1400 | 4V+   |
| 30-85<br>Bolted-in<br>Magnets<br>4 CYL | 1976-<br>1996 | 4357640-<br>OG291031  | 332-5772<br>114-5772*                                   | Blue to<br>Blue/Wh                | Red to<br>Red/Wh     | 5000-7000<br>2200-2400*         | 125-155<br>45-55*   | 180-<br>400V | 25-<br>100V                         | Brown to White/Black<br>Purple to White                  | 800-<br>1400 | 4V+   |
| 30-125<br>Red<br>Stator Kit<br>4 CYL   | 1976-<br>1996 | 4357640-<br>OG437999  | 332-5772<br>114-5772*                                   | Green/White to<br>White/Green     |                      | 500-700<br>500-600*             |                     | 180-<br>400V |                                     | Brown to White/Black<br>Purple to White                  | 800-<br>1400 | 4V+   |
| 40-125<br>Glued-in<br>Magnets<br>4 CYL | 1988-<br>1996 | OB209468-<br>OG437999 | 332-5772<br>114-5772*                                   | Blue to<br>Blue/Wh                | Red to<br>Red/Wh     | 3250-3650<br>500-600*           | 75-90<br>28-32*     | 180-<br>400V | 25-<br>100V                         | Brown to White/Black<br>Purple to White                  | 800-<br>1400 | 4V+   |
| 50-65<br>4 CYL                         | 1968-<br>1975 | 2309311-<br>4357639   | 333-3213  | Red to<br>White                   | Blue to<br>White     | 380-420                         | 9-11                | 180-<br>400V | 25-<br>100V                         | Ignition Driver  | N/A          | N/A   |
| 80-125<br>CDM<br>4 CYL                 | 1995-<br>2006 | OG141089-<br>1B999999 | 827509<br>114-7509*                                     | Green/White to<br>White/Green     |                      | 500-700<br>500-600*             |                     | 180-<br>400V |                                     | Engine Gnd to<br>Brown, White, Purple<br>and White/Black | Open         | 3V+   |
| 120<br>4 CYL                           | 1995          | OE080400-<br>OE141088 | 332-826866<br>114-6866*                                 | Blue to<br>Blue/Wh                | Red to<br>Red/Wh     | 3250-3650<br>500-600*           | 75-90<br>28-32*     | 180-<br>400V | 25-<br>100V                         | Brown to White/Black<br>Purple to White                  | 800-<br>1400 | 4V+   |

Blk = Black    Grn = Green    Pur = Purple    Yel = Yellow    Eng Gnd = Engine Ground    N/A = Not Applicable    Pri = Primary  
Brn = Brown    Org = Orange    Wht = White    Gnd = Engine Ground    COMM = Commercial    Sec = Secondary

\* Indicates a part manufactured by CDI Electronics

NOTE: Ignition Coils will read 0.2 to 1.0 ohms on the Primary and 800-1100 ohms on the Secondary windings

Appendix

# Appendix

## Mercury DVA (Peak Reading) Voltage and Resistance Chart

| HP                              | Year          | Model or Serial#      | Ignition Part Number                          | Read  |                                    | Stator Ohms                        |                             | DVA          |             | Trigger   |                                |     |
|---------------------------------|---------------|-----------------------|---|---|------------------------------------|------------------------------------|-----------------------------|--------------|-------------|---|--------------------------------|-----|
|                                 |               |                       |   | Low Spd   | High Spd                           | Low Spd                            | High Spd                    | Low Spd      | High Spd    | Read  | Ohms                           | DVA |
| 90-350<br>9-16 Amp<br>6 CYL     | 1976-<br>1994 | 4301235-<br>OG201874  | <del>332-7778</del><br>114-7778*              | Blue to<br>Gnd<br>Blue/Wht<br>to Gnd                                      | Red to<br>Gnd<br>Red/Wht<br>to Gnd | <del>5000-7000</del><br>2000-2400* | <del>90-200</del><br>30-90* | 180-<br>400V | 25-<br>100V | See NOTE 1  | 800-<br>1400                   | 4V+ |
| 105-275<br>40 Amp<br>6 CYL      | 1989-<br>2000 | OC100861-<br>OG960499 | <del>332-7778</del><br>114-7778*              | Blue to<br>Gnd<br>Blue/Wht<br>to Gnd                                      | Red to<br>Gnd<br>Red/Wht<br>to Gnd | <del>3200-4200</del><br>2000-2400* | <del>90-140</del><br>28-32* | 180-<br>400V | 25-<br>100V | See NOTE 1  | 800-<br>1400                   | 4V+ |
| 135-240<br>2.5L<br>CDM<br>6 CYL | 1996-<br>2005 | OE373939-<br>1B999999 | <del>827509</del><br>114-7509*                | Green/White to<br>White/Green   |                                    | 500-700<br>500-600*                |                             | 180-<br>400V |             | Purple to Blue<br>White to Red<br>Brown to Yellow | 1100-<br>1400<br>850-<br>1050* | 4V+ |
| 175-210<br>6 CYL                | 1997-<br>1999 | OE151580-<br>OE433133 | <del>18495</del><br>114-4953-32*              | Blue to<br>Gnd<br>Blue/Wht<br>to Gnd                                      | Red to<br>Gnd<br>Red/Wht<br>to Gnd | <del>3250-3650</del><br>500-600*   | <del>75-90</del><br>28-32*  | 180-<br>400V | 25-<br>100V | See NOTE 1  | 800-<br>1400                   | 4V+ |
| 225-250<br>3.0L<br>CDM<br>6 CYL | 1994-<br>2003 | OD280813-<br>OT408999 | <del>827509</del><br>114-7509K1*<br>114-7509* | Engine Gnd to Grn, Grn/<br>Red, Grn/Yel, Grn/Blue,<br>Grn/Org and Grn/Blk |                                    | 990-1210                           |                             | 100-<br>400V |             | N/A   | N/A                            | N/A |

**Blk = Black**      **Grn = Green**      **Pur = Purple**      **Yel = Yellow**      **Eng Gnd = Engine Ground**      **N/A = Not Applicable**      **Pri = Primary**  
**Brn = Brown**      **Org = Orange**      **Wht = White**      **Gnd = Engine Ground**      **COMM = Commercial**      **Sec = Secondary**

\* Indicates a part manufactured by CDI Electronics

NOTE 1: Read from (Yellow sleeve) to (Black sleeve)  
                   Brown      to      Purple  
                   White      to      Brown  
                   Purple     to      White

NOTE: Ignition Coils will read 0.2 to 1.0 ohms on the Primary and 800-1100 ohms on the Secondary windings

## **Appendix**

### **Glossary of Terms**

ADI – **Alternator Driven Ignition**, consists of a flywheel, stator, trigger and ignition module.

ADTC - **After Top Dead Center** Reference on ignition timing.

BTDC - **Before Top Dead Center** Reference on ignition timing.

CD Ignition – **Capacitive Discharge Ignition**. The capacitor stores the power developed by a stator or inverter and uses a SCR to deliver the power to the ignition coil.

CDM – **Capacitive Discharge Module**. The CDM is a combination of the switch box and ignition coil.

Crank - Refers to the engine being turned over with the starter, not running. Spark plug wires are usually connected to a spark gap tester.

DVA – **Direct Voltage Adapter**. Also known as Peak voltage. The term refers to the peak voltage as read by a specialized meter or a multimeter using an adapter to convert the peak voltage in the ignition system to a DC value. Regular meters cannot read the voltages due to the frequency and duration of the pulses in the system.

Power Pack – Term used by Johnson/Evinrude for the ignition module.

RPM – **Revolutions per minute**. The number of times the engine rotates in one minute.

S.L.O.W. – **Speed Limiting Oil Warning** system. Limits the RPM of the engine to approximately 2500 RPM in order to reduce the damage to the engine caused by a no oil or overheat condition.

Spark Tester - Device used to check for spark from the ignition coil to the spark plug. Testers are normally available in 1, 4, 6 and 8 cylinder configurations.

Switch Box – Term used for Force, Mariner and Mercury ignition modules.

W.O.T. – **Wide Open Throttle**.



## Appendix

---

### CDI ELECTRONICS

---

### OUTBOARD SERVICE BULLETIN

---

12/06/2003

CDI Bulletin # 2276 Rev.1

Models affected:     Johnson/Evinrude 60 HP 1986 (CE) through 1994 (ER)  
                          Johnson/Evinrude 65 HP 1987 (CU) through 1994 (ER)  
                          Johnson/Evinrude 70 HP 1989 (CD) through 1994 (ER)

#### Problem:

The engine and electrical system can become damaged by overheating when air is trapped in the upper half of the cooling system. Trapped air can cause the upper cylinder or regulator/rectifier to overheat, resulting in damage to the piston or regulator (also damaging the stator). Air can become trapped when:

1. The engine is idling with a blocked or restricted thermostat bypass hole.
2. The engine is operated in aerated water, such as a pontoon or deck boat wakes.

#### SOLUTION:

Relocate the water pump indicator outlet tee (for the pee tube) from the side of the engine block to the top of the engine cylinder block. This allows air to be vented from the top of the cooling system and helps ensure an adequate water level when idling.

**If the engine does not have a threaded hole located in the top of the cylinder block, please follow the steps below:**

1. Remove the indicator hose from the outlet tee and discard.
2. Remove the outlet tee.
3. Install a 1/8<sup>th</sup> inch NPT brass or aluminum pipe plug into the hole where the tee was located (use gel-seal on the threads). (See fig. 1)
4. Measure 2 inches forward from the rear corner of the exhaust manifold cover (ref "A") and 1-3/8<sup>th</sup> inches from the exhaust cover gasket (Ref to "B"). Mark the intersection with a center punch. (See fig. 2).
5. Mark an 11/32<sup>nd</sup> (Letter "R") drill bit 1/2 inch from the tip (to prevent damage to the water jacket) as a depth gauge. Grease the tip and drill a hole through the casting. The grease will help prevent shavings from entering the cooling system.
6. Grease the tip of an 1/8<sup>th</sup> NPT tap and thread the hole.
7. Apply gel-seal to the threads of the original tee and install it in the hole you just tapped. Position the tee so that the indicator nipple is facing the back of the engine.
8. Install a new piece of 3/16<sup>th</sup> hose (19 inches long) from the tee to the indicator.

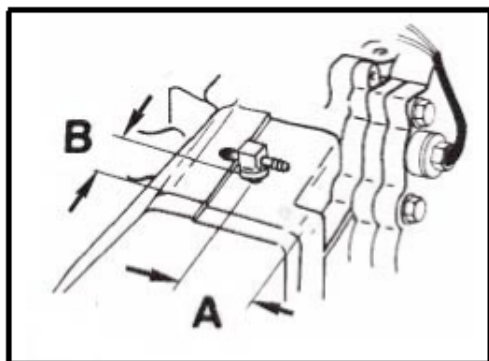

Fig. 1

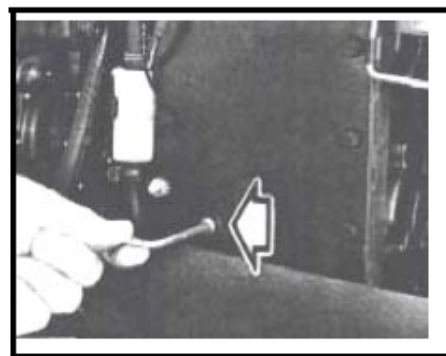

Fig. 2

## Appendix

No. 032410  
March, 2010

**Subject:** 35 Amp Stator Power Coil Over-Heating.

**Make:** Johnson & Evinrude  
**Horsepower:** 200/225/250 HP V6  
**Years:** 1993 through 2001

**Problem:**

The engine and electrical system can become damaged by overheating when air is trapped in the upper part of the cooling system. Trapped air can cause the regulator/rectifier to overheat, resulting in damage to the regulator (also damaging the stator) which is not covered under warranty.

**Air can become trapped in the top of the block at engine start-up when:**

- a) The engine is idling with a blocked or restricted thermostat.
- b) The engine is started and is not accelerated beyond 1800 RPM (the pop-off valve is designed to open and allow additional cooling water to circulate through the block when the RPM exceeds 1800 RPM). With age and wear, the seal for the pop-off valve plunger gradually conforms to the shape of the plunger and traps air in the top portion of the block. This prevents water from getting to the cooling fins of the regulator/rectifier, causing the regulator/rectifier to overheat and stressing the Stator. The first failure is typically the Power Coil on the Stator, progressing to damage to the rest of the Stator, Power Pack and regulator/rectifier.

**Air can also become trapped in the top of the block if:**

- a) The engine is operated in aerated water, such as a pontoon or deck boat wakes.
- b) The engine is operated too high on the transom.

**Solution:**

1. Remove the pop-off valve and disassemble it.
2. Using a 1/8" drill bit, drill a hole through the plunger from the back side of the plunger as close to the center as possible. This allows air to be vented from the top of the cooling system and helps ensure an adequate water level when the engine is run below 1800 RPM.
3. Re-assemble the pop-off valve and re-install it in the block as per the service manual. NOTE: It is recommended that the rectifier/regulator be replaced after the modification has been done as some of the rectifier/regulator's internal parts may have un-detectable damage.

## Appendix

### OMC Cobra Drive ESA Cross Reference

| Application                  | Years   | Type           | OEM P/N | Supersession | CDI P/N           | Coil    |
|------------------------------|---------|----------------|---------|--------------|-------------------|---------|
| 2.3L, 2.5L, 3.0L             | 86 - 88 | Points         | 984281  | 987740       | <b>123-9898-P</b> | 383444  |
| 2.3L, 2.5L, 3.0L, 4.3L       | 86 - 90 | Points         | 987740  |              | <b>123-9898-P</b> | 383444  |
| 2.3L, 2.6L, 3.0L, 4.3L       | 89 - 90 | Points         | 985902  | 987740       | <b>123-9898-P</b> | 383444  |
| 2.5L, 3.0L                   | 82 - 85 | Points         | 982755  |              | <b>123-9898-P</b> | 383444  |
| 3.0L, 3.0L HO                | 90      | Delco EST      | 986610  | 987396       | <b>123-7878</b>   | 986644  |
| 3.0L, 3.0L HO                | 90      | Delco EST      | 987396  | 987878       | <b>123-7878</b>   | 986644  |
| 3.0L, 3.0L HO                | 92 - 93 | Delco EST      | 987566  |              | <b>123-7566</b>   | 986644  |
| 3.0L, 3.0L HO                |         | Delco EST      | 987874  |              | <b>123-7566</b>   | 986644  |
| 3.0L, 3.0L HO                |         | Delco EST      | 987878  |              | <b>123-7878</b>   | 986644  |
| 3.0L, 4.3L, 5.0L, 5.7L, 5.8L | 91      | Switch Assy.   | 986900  |              | N/A               | N/A     |
| 3.0L, 4.3L, 5.0L, 5.7L, 5.8L | 92 - 93 | Switch Assy.   | 987602  |              | N/A               | N/A     |
| 3.2L, 5.7L, 7.4L, 7.5L       | 90 - 93 | Switch Assy.   | 986368  | 988039       | N/A               | N/A     |
| 3.8L, 4.3L                   | 82 - 85 | Points         | 982774  |              | <b>123-9898-P</b> | 383444  |
| 4.3L                         | 86 - 88 | Points         | 984036  | 986342       | <b>123-9898-P</b> | 383444  |
| 4.3L                         | 86 - 88 | Points         | 986342  | 987740       | <b>123-9898-P</b> | 383444  |
| 4.3L 2V only (HO 4V = EEM)   | 91      | Prestolite BID | 986999  | 987403       | <b>123-7567</b>   | 383444  |
| 4.3L 2V only (HO 4V = EEM)   | 91      | Prestolite BID | 987403  | 987875       | <b>123-7567</b>   | 383444  |
| 4.3L 2V only (HO 4V = EEM)   | 91      | Prestolite BID | 987875  |              | <b>123-7567</b>   | 383444  |
| 4.3L 2V only (HO 4V = EEM)   | 92 - 93 | Prestolite BID | 987567  |              | <b>123-7567</b>   | 987673  |
| 5.0L - 5.8L Ford             | ?? - 90 | Points         | 987739  |              | <b>123-9898-P</b> | 383444  |
| 5.0L, 5.7L                   | 82 - 85 | Points         | 982749  |              | <b>123-9898-P</b> | 383444  |
| 5.0L, 5.7L                   | 86 - 88 | Points         | 984276  | 984730       | <b>123-9898-P</b> | 383444  |
| 5.0L, 5.7L, 5.8L             | 89 - 90 | Points         | 974730  | 987739       | <b>123-9898-P</b> | 383444  |
| 5.0L, 5.7L, 7.5L Ford        | ?? - 90 | Points         | 987738  |              | <b>123-9898-P</b> | 383444  |
| 5.0L, 5.8L Ford              | 91      | Prestolite BID | 987876  |              | <b>123-7571</b>   | 383444  |
| 5.0L, 5.8L Ford              | 92 - 93 | Prestolite BID | 987564  |              | <b>123-7571</b>   | 383444  |
| 5.0L, 5.8L Ford              | 93      | Switch Assy.   | 987757  |              | N/A               | N/A     |
| 5.7L                         | 90 - 91 | EEM            | 986297  | 987495       | N/A               | 914636  |
| 5.7L                         | 91      | Prestolite BID | 987877  |              | <b>123-7571</b>   | 383444  |
| 5.7L                         | 91 - 92 | Prestolite BID | 987571  |              | <b>123-7571</b>   | 383444  |
| 5.8L                         | 93      | Switch Assy.   | 988038  |              | N/A               | N/A     |
| 5.8L                         | 93      | Switch Assy.   | 988039  | 3854432      | N/A               | N/A     |
| 5.8L                         | 94      | Switch Assy.   | 3854410 |              | N/A               | N/A     |
| 5.8L                         | 94      | Switch Assy.   | 3854431 |              | N/A               | N/A     |
| 5.8L                         | 94      | Switch Assy.   | 3854432 |              | N/A               | N/A     |
| 7.4L                         | 90 - 91 | EEM            | 986293  | 987497       | N/A               | 914636  |
| 7.4L                         | 94 - 95 | Switch Assy.   | 986361  | 3854133      | N/A               | N/A     |
| 7.4L                         | 94 - 95 | Switch Assy.   | 3854133 | 3854432      | N/A               | N/A     |
| 7.4L                         | 95      | Delco EST      | 3854714 |              | <b>123-7566</b>   | 3854002 |
| 7.5L Ford                    | 87 - 88 | Points         | 974730  | 987738       | <b>123-9898-P</b> | 383444  |
| Shift Switch for most        | 86 - 90 | Switch Assy.   | 984051  |              | <b>933-4051</b>   | N/A     |
|                              |         |                | 987000  | 987400       | N/A               |         |
|                              |         |                | 987400  |              | N/A               |         |

**Appendix**



**Breaker Points Wiring**

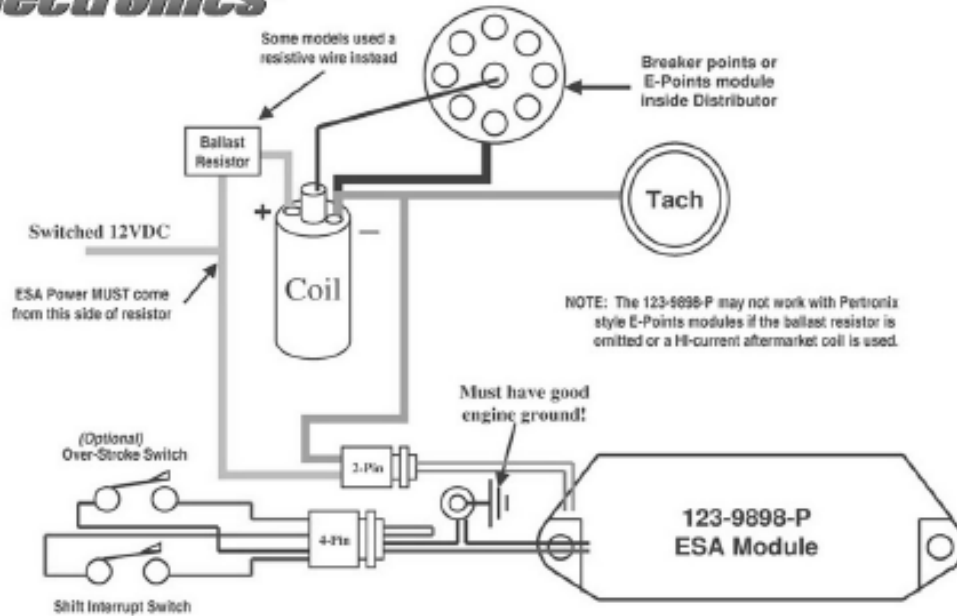

**Appendix**



**Delco EST Wiring**  
Electronic Spark Timing Distributor

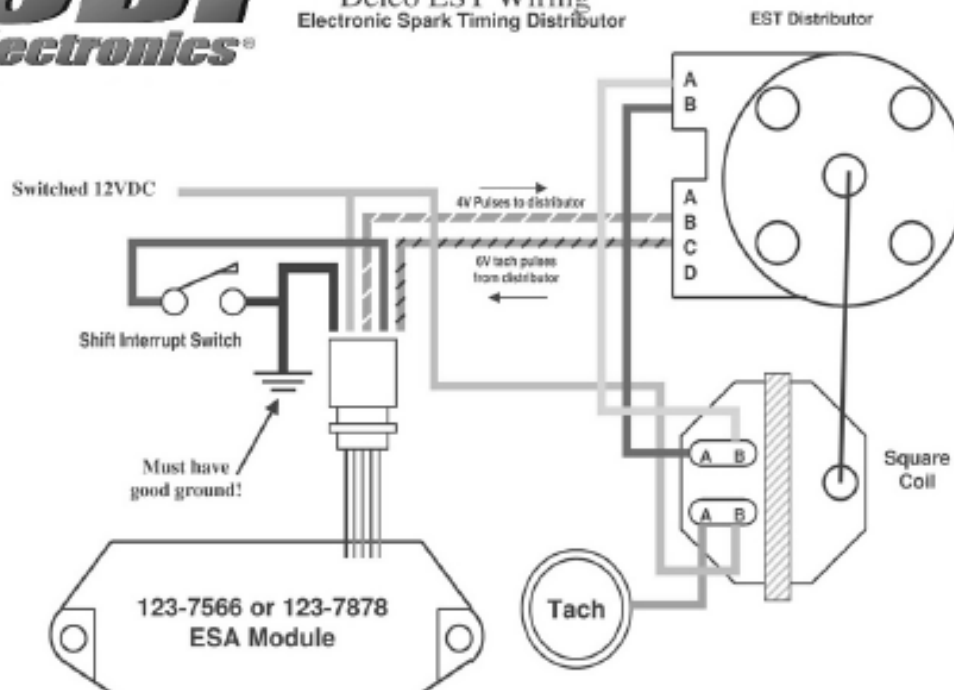

**Appendix**



**Prestolite BID Wiring**  
Breakerless Ignition Distributor

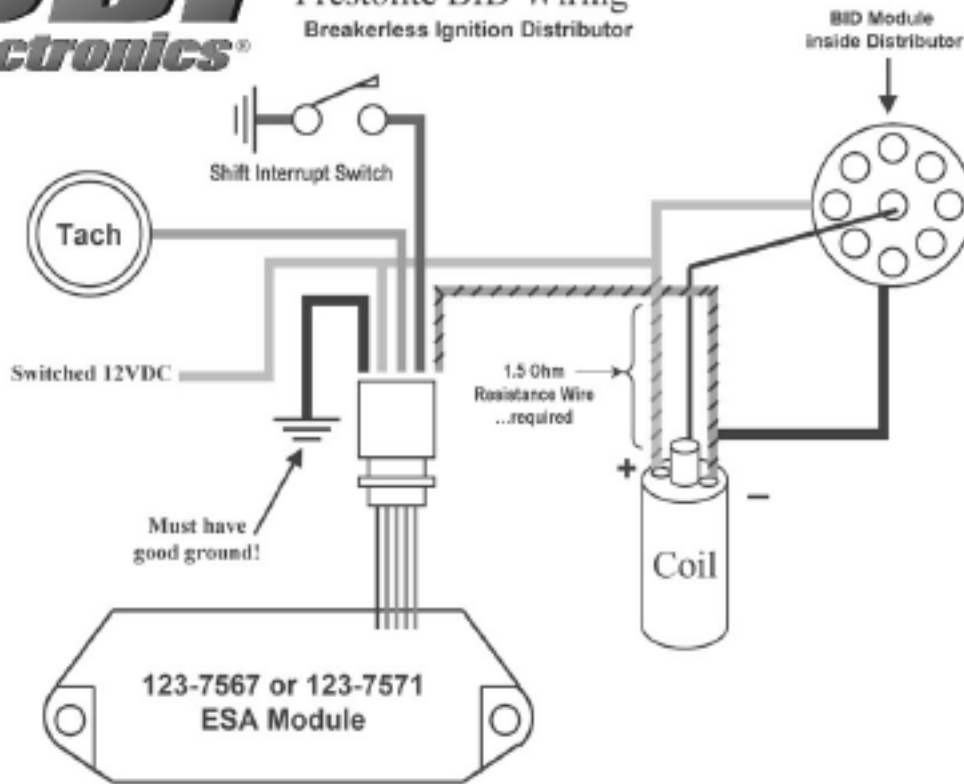



**Appendix**

Appendix